

Christie Velvet - Merit Series

1.5mm Indoor LED tile

Technical specifications		Christie LED015-M
Display technology	pixel pitch	• 1.5mm
	pixel configuration	• 3-in-1 (1R1G1B)
	pixel density	• 422,500 pixels/m ²
	maximum calibrated brightness	• 800 nits (cd/m ²)
	aspect ratio	• 1:1
	contrast ratio (full field)	• 5000:1
	viewing angle	• 160° H, 140° V
	refresh rate	• ≥3200Hz
	scan rate	• 1/26
	color temperature	• 2700-9300K
	color space	• 110% NTSC
	display colors	• 281 trillion
Signal	inputs	• HDMI (HDCP) • DVI (HDCP)
Power	input rating	• 100-240 VAC @ 50-60Hz
	power consumption per cabinet	• 50W typical • 160W maximum
	heat output	• 246 BTU/hr typical • 737 BTU/hr maximum
Environment	operating temperature	• 32-104°F (0-40°C)
	operating humidity	• 10-90% non-condensing
	storage temperature	• 14-131°F (-10-55°C)
	environment	• Indoor
	IP rating	• 30
	LED lifespan (50% brightness)	• 100,000 hrs
	runtime	• 24/7
	Physical	tile dimensions (installed)
tile area		• 2.48 ft ² (0.2304m ²)
tile resolution		• 312 x 312 pixels
tile weight		• 23.4lbs (11.5kg)
cabinet design		• Die-cast aluminum
service access		• Front and rear service only
module dimensions		• (WxH): 9.45 x 4.72" (240.0 x 120.0mm)
module resolution		• 156 x 78 pixels
installation options		• Flat • hanging • concave
stacking height		• 20 units ¹
orientation		• 360 degrees ²
Certification	• UL60950 • FCC • CE • EMC RoHS, RCM	
Warranty	<ul style="list-style-type: none"> • Three year parts and labor limited warranty • Contact an authorized Christie representative for full details of our limited warranty • Extended warranty option available for a one-time fee at time of purchase 	

¹ With appropriate structure. Contact Christie if height exceeds 20 units.
² Varies by local building codes.

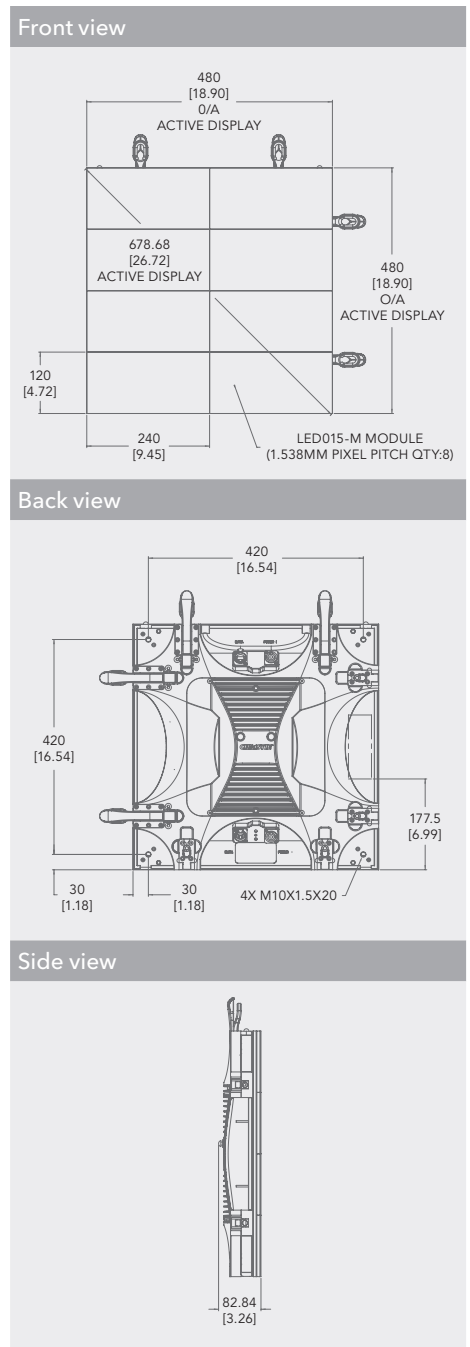

United Kingdom
 Branch & EMEA
 Head Office
 ViewPoint
 200 Ashville Way
 Wokingham
 Berkshire, U.K.
 RG41 2PL
 PH: +44 (0) 118 977 8000

Middle East
 Light Industrial Unit (LIU-17)
 Nad Al Shibba
 Sheikh Mohammed Bin Zayed Road
 Dubai Silicon Oasis
 PO Box: 293762
 Dubai - U.A.E
 PH: +971 (0) 4 503 6800

Africa
 Unit C3
 Northlands Deco Park
 New Market Road
 Northriding
 Randburg
 2164
 Johannesburg
 Gauteng
 South Africa
 PH: +27 71 335 8667

Other EMEA offices

Germany
 Branch Office
 PH: +49 2161 566 200

France
 Branch Office
 PH: +33 (0) 1 41 21 44 04

Eastern Europe
 Representative Office
 PH: +36 (0)1 47 48 138

Spain
 Branch Office
 PH: +34 91 633 9990

Italy
 Independent Sales Consultant Office
 PH: +39 (0) 2 9902 1161

Russia
 Independent Sales Consultant Office
 PH: +7 (495) 930-8961

For the most current specification information, please visit www.christieemea.com

Copyright 2016 Christie Digital Systems USA, Inc. All rights reserved. All brand names and product names are trademarks, registered trademarks or tradenames of their respective holders. Christie Digital Systems Canada Inc.'s management system is registered to ISO 9001 and ISO 14001. Performance specifications are typical. Due to constant research, specifications are subject to change without notice. Printed in Canada on recycled paper. 4147 Nov 15

CHRISTIE®