

Christie H Series

Auditoriums

Government

Houses of worship

Boardrooms

Higher education

Rental staging

Breakout rooms

Hotels



The industry's brightest, lightest
and most powerful 1DLP projector

CHRISTIE®

Christie H Series

The Christie® H Series combines high-brightness with excellent color reproduction and boasts 12,000 lumens. With superior image quality, flexible connectivity and less than half the noise of competitive products, the Christie H Series packs a lot of high-performance features into a surprisingly small and sleek package.

Best-in-class brightness

Christie D12WU-H

WUXGA - 12,000 center lumens

Christie D12HD-H

HD - 11,000 center lumens

Small, but mighty

Meet the 1DLP projector of your rental staging dreams

The Christie H Series is designed to bridge the gap between mid-sized and large venues, giving you an excellent option at an affordable price.

Enhance your projection solutions offering with the Christie H Series. With a black chassis and half the noise of the competition, it's perfect for discrete installations. The lightweight and sleek profile makes it easy to handle and ship, costing you less money with each installation. Plus, the available stacking and rigging frame, portrait capability, and advanced warping and blending capabilities give you the design freedom you crave.

The Christie H Series also features a full suite of lens options and compatibility with Christie E Series lenses, making it a cost-effective and flexible solution.



▲ Rigging/stacking frame - portrait orientation



Hush.

Listen closely. Do you hear it?

It's the impossibly quiet Christie H Series. If you're dealing with mid-sized to large venues, this is the one you've been waiting for.

The Christie H Series boasts half the noise of competitors, the highest 1DLP® brightness in the industry, and it's easy on the eyes too. Experience the best of both worlds with high-brightness and color integrity, all in one affordable projection solution. Balancing bright, vivid images with a sleek, elegant design, the Christie H Series blends into any environment to let image performance take center stage.

Ideal for discrete installs, the available ceiling mount, extender rod and rigging clamp ensure a smooth installation process. Plus, with an input panel cover plate and bottom-side HDMI input connection to hide unsightly cords, and a choice between white and black models to suit your environment, the focus is all on the color-rich images you'll have on display.



▲ Second HDMI connector on the bottom of projector

Designed for performance

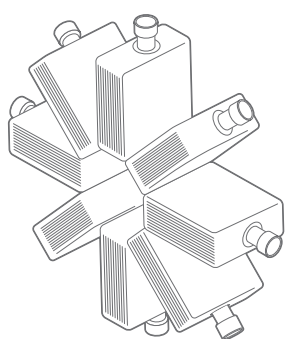

▲ 360 degree projection



▲ Input panel

Blending and warping capabilities

Blending and warping are easy with the new Christie® H Series software and the use of off-the-shelf standard cameras¹. The software and camera option allow for easy and quick edge-blending and stacking capabilities with advanced grid control for more complicated, finite correction. You can also use the software to set up multiple projectors for warping images (advanced geometry correction) or for multi-projector blending to create large panoramic seamless displays.

3D capability

Add an edge to boardroom meetings or lecture hall presentations with consumer-grade 3D capability. Utilizing either HDMI or HDBaseT™ inputs, the Christie H Series has an output of up to 120Hz and includes frame packing, side-by-side and top/bottom 3D capabilities built right in.



Portrait mode and 360 degree projection

Projectors can be used in portrait orientation using existing lamps², reducing your set-up time and minimizing extra costs for special lamps. They can also be installed in a 360 degree configuration.

Enhanced lamp options

Dual-lamp design lets you maximize brightness or extend lamp life. Lamp life is 1500 hours typical @ 465W and 2000 hours typical @ 370W.

Digital Imaging and Communication in Medical (DICOM) simulation

DICOM simulation mode provides enhanced grey scale levels for medical training³ applications requiring DICOM part 14 specifications.



▲ Standard mode



▲ DICOM simulation mode

Connectivity

The Christie H Series uses HDBaseT to provide the latest in intelligent and flexible connectivity, by allowing for both video content and control to be delivered over low cost CAT5/6e cabling.

3G SDI enables video integrity over long distances. A second RJ-45 input enables dedicated control of the projector if required.

An additional second HDMI connector on the bottom of the chassis provides clean, discrete installations with no visible cables.

¹ Logitech HD Pro Webcam C920 is the recommended model.
² Reduced lamp life.
³ Simulation mode is for training purposes only, not for medical diagnostics of actual patients.



Variety of lens options to choose from

A full suite of lenses, including an adapter for the Christie E Series lenses ensures design freedom and flexibility for installation.

Lens options⁴

Description	Part number
0.84-1.02:1 zoom lens*	140-114107-01
1.02-1.36:1 zoom lens*	140-115108-01
1.2-1.5:1 zoom lens (Full ILS)	140-109101-01
1.5-2.0:1 zoom lens (Full ILS)	140-110103-01
2.0-4.0:1 zoom lens (Full ILS)	140-111104-01
Christie H Series adapter for Christie E Series lenses	140-112105-01

* No zoom/focus memory

Projector color options

Christie D12WU-H	Part number
Black	140-009100-01
White	140-009133-01

Christie D12HD-H	Part number
Black	140-010102-01
White	140-010135-01

Christie Presenter

The Christie Presenter application allows up to four remote desktops from host PC's to be displayed on the network through Ethernet, USB, or wireless transports. It can adapt to different network settings (DHCP, fixed IP, and direct link) by USB/Ethernet cable.



Wireless projection

Easy connectivity
Less cluttered meeting space
Cable-free management

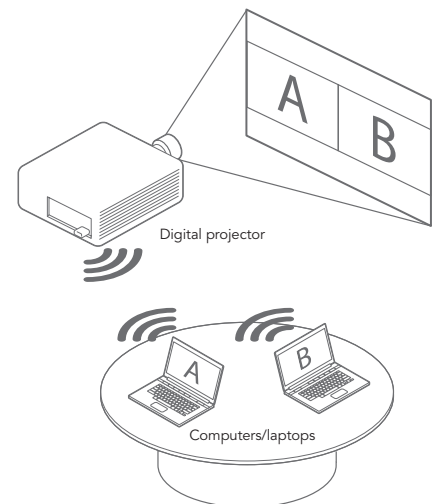

▲ Wireless capability

◀ Christie H Series wireless dongle

⁴ Throw ratio varies by resolution. See www.christiedigital.com for further information.

Christie support and service

All Christie® products are backed by industry-leading warranties, renowned service and support. We ensure our customers are well equipped with training, service and technical assistance available through our extensive distribution and support network.

Christie also offers support for international installations and global deployments, with representatives on five continents.

We offer customer-centric service with years of extensive experience in varieties of applications.



		Christie D12WU-H	Christie D12HD-H	
Image	brightness	<ul style="list-style-type: none"> • 12,375 lumens (compliant with ISO 21118) • Center: 12,000 lumens • ANSI: 11,000 lumens 	<ul style="list-style-type: none"> • 11,250 lumens (compliant with ISO 21118) • Center: 11,000 lumens • ANSI: 10,000 lumens 	
	contrast (nominal)	• 5000:1 (Dynamic Aperture Enabled) • 1200:1 Full On/Off • 250:1 ANSI		
Display	type	• 1-chip 0.96" DMD	• 1-chip 0.95" DMD	
	native resolution	• 1920 x 1200 (2,304,000 pixels) 16:10	• 1920 x 1080 (2,073,600 pixels) 16:9	
	color wheel	• 6 Segment (RGBCYW)		
Lamp	type	• 465W (003-005237-01) x 2		
	typical lifetime	• 1500 hrs minimum @ 465W • 2000 hrs typical @ 370W		
Inputs	standard	<ul style="list-style-type: none"> • 3G-SDI x 1 (BNC) • HDMI x 2 (One on side panel, one on bottom of projector, independently selectable) • DVI-D x 1 (Digital only) • Display Port x 1 • HD15 x 1 • RGBHV/Component (5 BNC) • Composite Video x 1 (BNC) • S-Video x 1 (mini DIN) • Component Video (RCA) • USB x 1 (type B mini) - display over USB • USB x 1 (type A) - image viewer or WiFi* dongle (optional) • HDBaseT (RJ45 x 1) • RJ45 x 1 (Christie Presenter over wired network connection) 		
	3D ¹	<ul style="list-style-type: none"> • HDMI, HDBaseT - frame packed, side by side, top/bottom • 3D Sync In (BNC) - for genlocking projectors • 3D Sync Out (BNC) - for genlocking projectors or controlling emitter or polarizer 		
	signals	<ul style="list-style-type: none"> • HDTV formats VGA through to WUXGA (1920 x 1200) • Horizontal and vertical scaling while maintaining aspect ratio, all inputs 		
	pixel clock	• 162 MHz		
	scan rates	• Horizontal: 15-100kHz • Vertical: 24-85Hz		
	Outputs	monitor out	• HD15 x 1	
	Control and networking		<ul style="list-style-type: none"> • RS232 In • Control via HDBaseT • Ethernet (10/100) RJ45 with ChristieNET™ connectivity • Built-in backlit keypad • Wired remote control (3.5mm stereo) - loop out available for daisy chaining 	
Lens mount	type	<ul style="list-style-type: none"> • Tool-free lens insertion system • Bore-sight adjustable • Motorized horizontal and vertical lens offset (memory available) • Motorized zoom and focus adjustment (memory available for full ILS lenses) 		
Lens options	lenses	<ul style="list-style-type: none"> • 0.84-1.02:1 zoom lens (no zoom/focus memory) • 1.02-1.36:1 zoom lens (no zoom/focus memory) • 1.2-1.5:1 zoom lens (full ILS) • 1.5-2.0:1 zoom lens (full ILS) • 2.0-4.0:1 zoom lens (full ILS) 		
	offsets (full ILS lenses)	<ul style="list-style-type: none"> • ± 120% Vertical (± 720 pixels) • ± 50% Horizontal (± 480 pixels) 	<ul style="list-style-type: none"> • ± 133% Vertical (± 720 pixels) • ± 50% Horizontal (± 480 pixels) 	
Accessories	standard	<ul style="list-style-type: none"> • IR remote w/wired remote jack (wire not included) • Coarse dust filters - 3 pack (not mandatory for standard use) • AC line cords for projector head • User manual 		
	optional	<ul style="list-style-type: none"> • Rigging/stacking frame • Lens adapter for E Series lenses • 1DWUSB-BGN (wireless dongle for video and control) • Fog filters - 3 pack • Ceiling mount • Ceiling mount extension rod • Ceiling mount rigging clamp • Replacement remote control 		
Power requirements	operating voltage	• 100-240 VAC @ 50/60Hz		
	consumption	• Normal mode: 1100W max (220V) 1180W max (110V) • Eco mode: 880W max (220V), 950W (110V)		
	operating current	• 5.5A max (220V) • 12A max (110V)		
	dissipation	• 3753 BTU/hr max • 3003 BTU/hr Eco mode		
Physical	size	• (LxWxH) 23.78 x 20.47 x 7.16" (604 x 520 x 182mm) w/o feet		
	weight (w/o lens)	• 52.5lbs (23.8kg)		
	shipping size	• (LxWxH) 31.10 x 26.22 x 13.86" (790 x 666 x 352mm)		
	shipping weight	• 62.8lbs (28.5kg)		
Operating environment	operating temperature	• 32-104° F (0-40° C)		
	humidity	• 10-85% non-condensing		
	noise	• Typical: 465W: 40dB(A) • 370W Eco mode: 37dB(A)		
Regulatory		<ul style="list-style-type: none"> • UL/CSA/IEC 60950- • FCC Class A, CE, CCC, KC, PSE, CU, SABS, BIS, VCCI, RCM • This product conforms to all relevant European directives, standards, safety, health and environmental concerns • RoHS, REACH, WEEE 		
Limited warranty		<ul style="list-style-type: none"> • 3 years parts and labor (including light engine) • Lamp: 500 hours or one year (whichever comes first) • Contact an authorized Christie representative for full details of our limited warranty 		

¹ Functionality is included in hardware, but not available until new firmware is released.



▲ Fog filter - 3-Pack P/N 003-005240-01 ▲ Coarse dust filter - 3-Pack P/N 003-005241-01



▲ Rigging/stacking frame - landscape orientation P/N 140-113106-01



▲ Ceiling mount extension rod P/N 121-125109-01



▲ Ceiling mount P/N 108-506102-XX



▲ Ceiling mount rigging kit P/N 121-126100-01

Top view

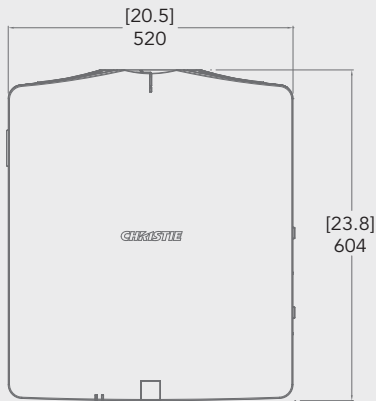

Bottom view

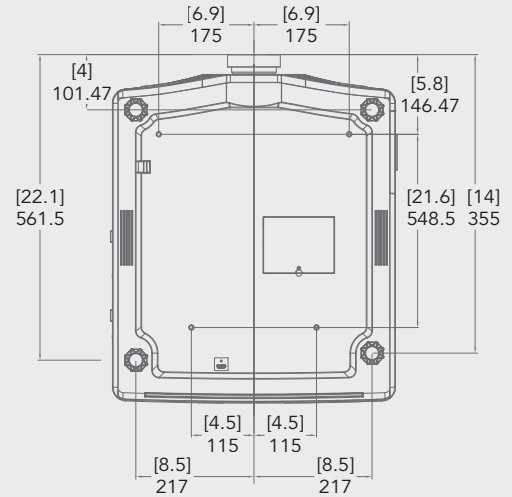

Front view

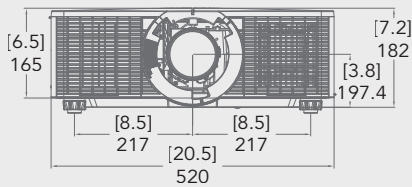

Right side view

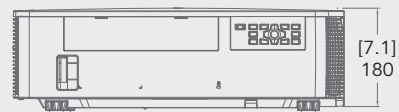

United Kingdom
Branch & EMEA
Head Office
ViewPoint
200 Ashville Way
Wokingham
Berkshire, U.K.
RG41 2PL
PH: +44 (0) 118 977 8000

Middle East
Light Industrial Unit (LIU-17)
Nad Al Shibba
Sheikh Mohammed Bin Zayed Road
Dubai Silicon Oasis
PO Box: 293762
Dubai - U.A.E
PH: +971 (0) 4 503 6800

Africa
Unit C3
Northlands Deco Park
New Market Road
Northriding
Randburg
2164
Johannesburg
Gauteng
South Africa
PH: +27 71 335 8667

Other EMEA offices

Germany
Branch Office
PH: +49 2161 566 200

France
Branch Office
PH: +33 (0) 1 41 21 44 04

Eastern Europe
Representative Office
PH: +36 (0)1 47 48 138

Spain
Branch Office
PH: +34 91 633 9990

Italy
Independent Sales Consultant Office
PH: +39 (0) 2 9902 1161

Russia
Independent Sales Consultant Office
PH: +7 (495) 930-8961



For the most current specification information, please visit www.christieemea.com

Copyright 2015 Christie Digital Systems USA, Inc. All rights reserved. All brand names and product names are trademarks, registered trademarks or tradenames of their respective holders. Christie Digital Systems Canada Inc.'s management system is registered to ISO 9001 and ISO 14001. Performance specifications are typical. Due to constant research, specifications are subject to change without notice.
Printed in Canada on recycled paper. 4038 Mar 15

CHRISTIE®