

Christie Q Series

Auditoriums

Boardrooms

Conference rooms

Education

Events

Government

Health care

Houses of worship

Meeting rooms

Rental and staging

Video mapping



Available in black

Bringing performance to new
levels in an affordable solution

CHRISTIE®

Christie Q Series

The Christie® Q Series takes projectors to a new level of high-brightness to bring you the industry's highest-quality 1-chip DLP® projector. Deliver your presentations and video content clearly with image quality that you would expect from Christie. With a range of projection options, sleek overall style and high-performance features, the Christie Q Series brings you superior image processing, versatility and affordability.



Best-in-class brightness

Christie DWX851-Q WXGA - 7500 ANSI lumens	Christie DHD851-Q HD - 7200 ANSI lumens	Christie DWU851-Q WUXGA - 7500 ANSI lumens
---	---	--

Christie DWX951-Q WXGA - 8500 ANSI lumens	Christie DHD951-Q HD - 8200 ANSI lumens	Christie DWU951-Q WUXGA - 8500 ANSI lumens
---	---	--

Christie DXG1051-Q
XGA - 10,000
ANSI lumens

Advanced features for superior image quality

eClarity

Our eClarity advanced image processing enhances your content by improving sharpness, gloss and shading, perfect for making non-HD content look like HD. Use eClarity to improve your standard and high-definition content for a brilliant, true-to-life image reproduction.



▲ Unadjusted image

▲ Adjusted image



▲ Sharpen

▲ Gloss

▲ Shade

Built-in dual-color wheel

A set of two color wheels are built into the projector and can be selected at a touch of a button. The built-in color wheels allow for easy switching between high-brightness or ultra-rich color reproduction mode, perfect for your presentation needs. In large venues the high-brightness color wheel gives you maximum output and superior white levels. The ultra-rich color wheel expands the color gamut for incredible reproduction that rivals cinema color standards.

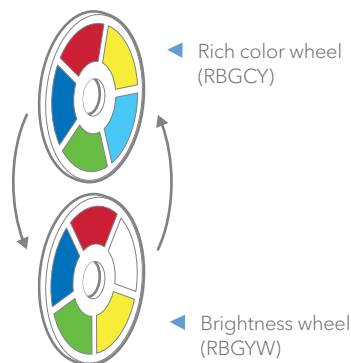

High Dynamic Contrast Range

High Dynamic Contrast Range (HDCR) improves visual contrast to avoid giving content a washed out effect in environments with a lot of ambient light. HDCR helps by adjusting the dynamic contrast level which will help recapture detail lost by excess ambient light on the screen.



◀ HDCR off



◀ HDCR on

Advanced image control

Motion-adaptive de-interlace delivers improved viewing of video content and fast-moving motion graphics. On-image display of gamma and color balance equalization allows you to manipulate your image configuration in real time.



◀ Standard video capture



◀ Digital rapid motion-adaptive de-interlacer

Designed for performance

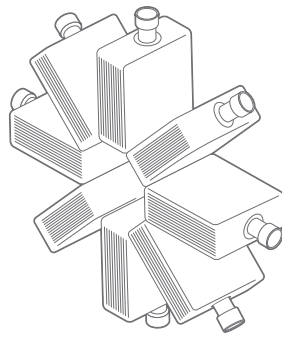

▲ 360 degree projection



▲ Standard mode



▲ DICOM simulation mode

Blending or warping capabilities

Blending or warping are easy with the new Q Series software and the use of off-the-shelf standard cameras¹. The software and camera option allow for easy and quick edge-blending capabilities. You can also use the software to setup multiple projectors for warping images (advanced geometry correction) or for multi-projector blending to create large panoramic seamless displays.

Broad variety of lensing options

New lens shift capability with our ultra-short throw lenses allows you to install projectors as close as necessary to your projected image without compromising display size.

Multiple screens, or creative projection on multiple areas, are not a problem with up to three memory settings for lens shift, zoom and focus recalls.

Portrait mode and 360 degree projection

Projectors can be used in portrait orientation using existing lamps, reducing your set-up time and minimizing extra costs for special lamps. They can also be installed in a 360 degree configuration.

Enhanced lamp options

Dual-lamp design lets you maximize brightness or extend lamp life. Lamps can be used in relay, eco, auto backup and balance mode. Lamp life is up to 2000 hours for standard mode, up to 4000 hours for eco 2-lamp and up to 8000 hours in optional lamp relay modes. The lamps are also designed to be swapped out without shutting down the projector².

Connectivity

HDBaseT provides the latest in intelligent and flexible connectivity, simplifying installation and management by allowing for video content, audio and control to be delivered over low cost CAT5/6e cabling to HDBaseT-compatible products.

Digital Imaging and Communication in Medical (DICOM) simulation

DICOM simulation mode provides enhanced grey scale levels for medical training³ applications requiring DICOM part 14 specifications.

Built-in LCD information display

The LCD display gives you real-time diagnostic information, assisting in network setup or helping with troubleshooting. Examples of some display options:

Lamp time
Filter hours
Projector usage
IP address

¹ Logitech : HD Pro Webcam C910 / HD Pro Webcam C920; Canon Digital SLR: T1i / T2i / T3 / T3i.

² Please reference manual for activating feature.

³ Simulation mode is for training purposes only, not for medical diagnostics of actual patients.



Variety of lens options to choose from

Our suite of lenses give you the range to install from a 0.8:1 all the way to a 9.2:1 throw ratio⁴.

Lens options⁴

Description	Part number
0.8-1.0 extra short throw zoom	121-118101-01
1.2-1.8/1.1-1.7 short throw zoom	121-119102-01
1.7-2.6/1.6-2.4 standard zoom (WXGA/WUXGA)	121-120104-01
1.7-2.5 standard zoom (XGA)	121-121105-01
2.5-3.8/2.4-3.6 middle throw zoom	121-122106-01
3.6-5.8/3.7-5.9/3.5-5.6 long throw zoom	121-123107-01
5.7-9.1/5.8-9.2/5.5-8.8 extra long throw zoom	121-124108-01

Wireless presentation and projector control

Using Christie® Q Series projectors and the Christie QuickConnect App you can project photos, documents and websites over Wi-Fi® from your iOS or Android™ based mobile digital devices.



▲ Choice between black or white models in every resolution

Christie support and service

All Christie products are backed by industry-leading warranties, renowned service and support. We ensure our customers are well supported with training, service and technical support through our extensive distribution and support network.

Christie has local support on five continents offering support for international installations and global deployments.

We offer customer-centric service with years of extensive experience in varieties of applications.



⁴ Throw ratio varies by resolution. See www.christiedigital.com for further information.

		Christie DWX851-Q	Christie DHD851-Q	Christie DWU851-Q
Image	brightness	• 7500 ANSI lumen - (7900 center lumens)	• 7200 ANSI lumens - (7500 center lumens)	• 7500 ANSI lumens - (7900 center lumens)
	contrast	• 2500:1 full on/off		
	uniformity	• ≤90% brightness uniformity		
Display	type	• 1-chip 0.65" DLP	• 1-chip 0.65" DLP	• 1-chip 0.67" DLP
	native resolution	• WXGA (1280 x 800)	• HD (1920 x 1080)	• WUXGA (1920 x 1200)
	color wheels	• Built-in color wheel (CW) options: high-brightness CW segments = RGBYW/ultra rich CW segments = RGBYC		
Lamp	type	• 350W UHP x 2		
	typical lifetime	• Standard mode: up to 2000 hrs • Eco mode: up to 4000 hrs • Portrait mode: up to 1000 hrs		
Inputs	standard	• Computer D-sub 15 pin mini jack x 1 • BNC connector x 1 (composite) • HDMI connector x 2 • DVI-D connector x 1 /RJ-45 x 1 (HDBaseT) • D-sub 9 pin x 1 (RS232c) • RJ-45 x 1 (LAN) • USB type A connector x 1 (Optional Wireless USB or PC-less) • Wired remote control (3.5mm)		
		• 5BNC connector x 1 • BNC connector x 1 (composite)	• 3G-SDI (only available on DHD851-Q)	• 5BNC connector x 1 • BNC connector x 1 (composite)
	optional	• Optional wireless dongle (USB)		
	signals	• 525i(480i) • 525p(480p) • 625i(576i) • 1125i(1080i@50/60) • 750p(720p@50/60) • 1125p(1080p@50/60)		
	pixel clock	• 27 ~ 150 MHz		
Outputs	standard	• Computer out D-sub 15 pin mini jack x 1 • Wired remote control (3.5mm)		
Control and networking		• RJ-45 x 1 (LAN) • RJ-45 x 1 (HDBaseT) • D-sub 9 pin x 1 (RS232c)		
Lenses		• For further details on lenses, please see www.christiedigital.com		
Accessories	standard	• Power cord (US cord, 3m) / (Euro code, 3m) /Power cord (China cord, 3m only for China models) • RGB cable (2m) • Wireless remote control / AA batteries x 2 • Adapter cover • Ferrite core and band x 2 • Cable tie x 2 • User's manual CD (safety guide) • Quick setup guide • Network quick setup guide • Operating guide • Network guide • Network guide • Instant stack guide • Technical guide • Software license agreement x 1 • User's manual		
	optional	• Replacement lamp (003-005160-01) • Replacement hybrid filter (003-004775-X) • Optional wireless dongle (USB) (121-116109-XX) • Replacement remote		
Enhanced feature sets		• 2 HDMI input • eClarity and HDCR • Built-in ultra-rich color wheel • HDBaseT • Portrait mode capable • Edge blending • Geometric correction • Status monitor display • Motorized zoom, focus and lens shift with memory • PC-less presentation • 3G-SDI (HD models only)		
Power requirements	operating voltage	• 110-120 VAC • 220-240 VAC		
	consumption	• AC110-120V, 50/60Hz 860W • AC220-240V, 50/60Hz 810W • Less than 0.5W @ standby with saving. (AC230V) • Saving mode disables MONITOR OUT, AUDIO OUT, speaker sound, LAN communication and RS232C control except Power ON command in standby		
	operating current	• 8.8A +10% or less at 110-120 VAC • 4.3A+10% or less at 220-240 VAC		
	dissipation	• 2935 BTU/hr (110-120V) • 2765 BTU/hr (220-240V)		
Physical specs	size	• (LxWxH) 18.2 x 21.1 x 6.9" (463 x 537 x 174mm) without lens and feet in minimum position		
	shipping size	• (LxWxH) 22.1 x 29.3 x 12.4" (561 x 743 x 315mm) without lens and feet in minimum position		
	weight	• 37.5lbs (17kg)		
	shipping weight	• 49.6lbs (22.5kg)		
Operating environment	noise	• Standard mode: 36dBA • Eco mode: 29dBA		
	operating temperature	• 32-113°F (0-45°C) from sea level to 5249ft (1600m) • 32-104°F (0-40°C) from 5249ft (1600m) to 10,000ft (3048m)		
	altitude	• 0-10,000ft (3048m)		
	humidity	• 10-80% non-condensing		
Regulatory		• This product conforms to the following regulations related to product safety, environmental requirements and electromagnetic compatibility (EMC) • FCC, Part 15, Subpart B, Class A • EN55022/CISPR22 Class A • ICES/NMB003 (A) • EN55024 / CISPR24 • IEC 60950-1 • UL 60950-1 • EN 60950-1 • CAN/CSA C22.2 No. 60950-1 • Directive 2011/65/EU (RoHS) • Directive 2012/19/EU (WEEE) • EU Regulation (EC) No. 1907/2006 (REACH) • Certifications marks (check with Christie for latest update): cULus (Canada & US), CE (EU), CCC (China), EAC (Russia), RCM (Australia and New Zealand), India (BIS), Mexico (NOM), Saudi Arabia, South Africa		
Limited warranty		• Three years parts and labor limited warranty • Lamp: 500 hours or one year (whichever comes first) • Contact an authorized Christie representative for full details of our limited warranty		

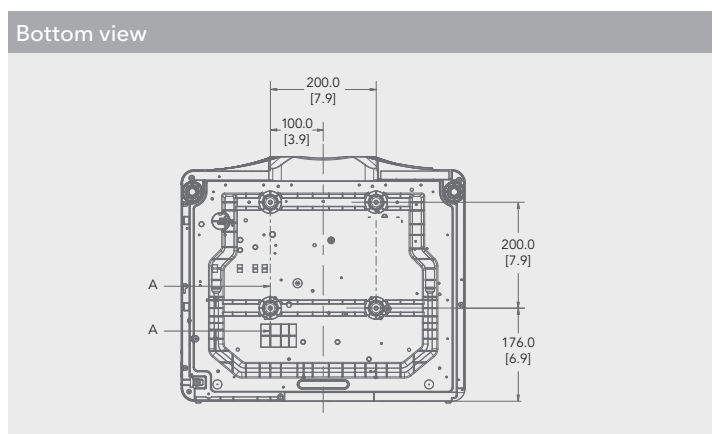
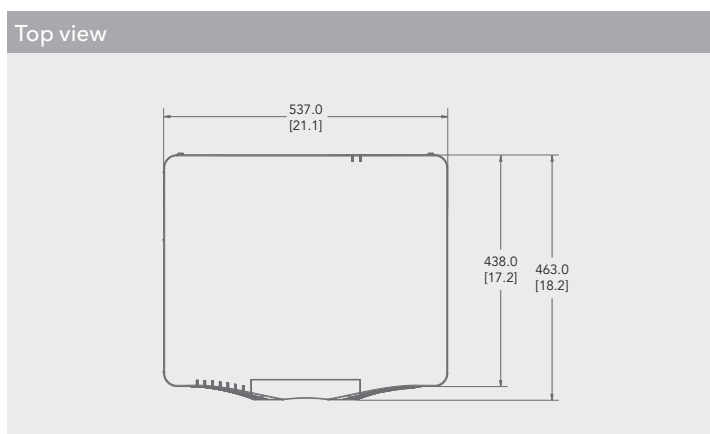

		Christie DWX951-Q	Christie DHD951-Q	Christie DWU951-Q	Christie DXG1051-Q
Image	brightness	• 8500 ANSI lumen - (8900 center lumens)	• 8200 ANSI lumens - (8500 center lumens)	• 8500 ANSI lumens - (8900 center lumens)	• 10,000 ANSI lumens - (10,400 center lumens)
	contrast	• 2500:1 full on/off			• 2000:1 full on/off
	uniformity	• ≤90% brightness uniformity			
Display	type	• 1-chip 0.65" DLP	• 1-chip 0.65" DLP	• 1-chip 0.67" DLP	• 1-chip 0.7" DLP
	native resolution	• WXGA (1280 x 800)	• HD (1920 x 1080)	• WUXGA (1920 x 1200)	• XGA (1024 x 768)
	color wheels	• Built-in color wheel (CW) options: high-brightness CW segments = RGBYW/ultra rich CW segments = RGBYC			
Lamp	type	• 370W P-VIP x 2			
	typical lifetime	• Standard mode: up to 2000 hrs • Eco mode: up to 4000 hrs			
Inputs	standard	• Computer D-sub 15 pin mini jack x 1 • BNC connector x 1 (composite) • HDMI connector x 2			
		• DVI-D connector x 1 /RJ-45 x 1 (HDBaseT) • D-sub 9 pin x 1 (RS232c) • RJ-45 x 1 (LAN)			
	optional	• USB type A connector x 1 (Optional Wireless USB or PC-less) • Wired remote control (3.5mm)			
		signals	• 5BNC connector x 1	• 3G-SDI (only available on DHD951-Q)	• 5BNC connector x 1
Outputs	standard	• BNC connector x 1 (composite)	• BNC connector x 1 (composite)	• BNC connector x 1 (composite)	• BNC connector x 1 (composite)
	pixel clock	• Optional wireless dongle (USB)			
Control and networking		• 525i(480i) • 525p(480p) • 625i(576i) • 1125i(1080i@50/60) • 750p(720p@50/60) • 1125p(1080p@50/60)			
Lenses		• 27 ~ 150 MHz			
Accessories	standard	• Computer out D-sub 15 pin mini jack x 1 • Wired remote control (3.5mm)			
	optional	• RJ-45 x 1 (LAN) • RJ-45 x 1 (HDBaseT) • D-sub 9 pin x 1 (RS232c)			
Enhanced feature sets		• For further details on lenses, please see www.christiedigital.com			
Power requirements	operating voltage	• Power cord (US cord, 3m) / (Euro code, 3m) /Power cord (China cord, 3m only for China models) • RGB cable (2m)			
	consumption	• Wireless remote control / AA batteries x 2 • Adapter cover • Ferrite core and band x 2 • Cable tie x 2			
	operating current	• User's manual CD (safety guide) • Quick setup guide • Network quick setup guide • Operating guide • Network guide			
	dissipation	• Network guide • Instant stack guide • Technical guide • Software license agreement x 1 • User's manual			
Physical specs	size	• Replacement lamp (003-004774-XX)	• Replacement lamp (003-005053-01)	• Replacement lamp (003-004774-XX)	• Replacement lamp (003-004774-XX)
	shipping size	• Replacement hybrid filter (003-004775-X)			
	weight	• Optional wireless dongle (USB) (121-116109-XX) • Replacement remote			
	shipping weight	• 2 HDMI input • eClarity and HDCR • Built-in ultra-rich color wheel • HDBaseT • Portrait mode capable			
Operating environment	noise	• Edge blending • Geometric correction • Status monitor display • Motorized zoom, focus and lens shift with memory			
	operating temperature	• PC-less presentation • 3G-SDI			
	altitude	• 110-120 VAC • 220-240 VAC			
	humidity	• AC110-120V, 50/60Hz 1060W • AC220-240V, 50/60Hz 990W			
Regulatory	operating current	• Less than 0.5W @ standby with saving. (AC230V) • Saving mode disables MONITOR OUT, AUDIO OUT, speaker sound, LAN communication and RS232C control except Power ON command in standby			
	weight	• 10.5A +10% or less at 110-120 VAC • 5.2A+10% or less at 220-240 VAC			
	shipping weight	• 3618 BTU/hr (110-120V) • 3379 BTU/hr (220-240V)			
	shipping size	• (LxWxH) 18.2 x 21.1 x 6.9" (463 x 537 x 174mm) without lens and feet in minimum position			
Limited warranty	weight	• (LxWxH) 22.1 x 29.3 x 12.4" (561 x 743 x 315mm) without lens and feet in minimum position			
	shipping weight	• 37.5lbs (17kg)			
	noise	• 49.6lbs (22.5kg)			
	operating temperature	• Standard mode: 36dBA • Eco mode: 29dBA			
Regulatory	altitude	• 32-113°F (0-45°C) from sea level to 5249ft (1600m)			
	humidity	• 32-104°F (0-40°C) from 5249ft (1600m) to 10,000ft (3048m)			
	operating current	• 0-10,000ft (3048m)			
	shipping weight	• 10-80% non-condensing			
Regulatory	operating voltage	• This product conforms to the following regulations related to product safety, environmental requirements and electromagnetic compatibility (EMC) • FCC, Part 15, Subpart B, Class A • EN55022/CISPR22 Class A • ICES/NMB003 (A)			
	consumption	• EN55024 / CISPR24 • IEC 60950-1 • UL 60950-1 • EN 60950-1 • CAN/CSA C22.2 No. 60950-1 • Directive 2011/65/EU (RoHS)			
	operating current	• Directive 2012/19/EU (WEEE) • EU Regulation (EC) No. 1907/2006 (REACH)			
	dissipation	• Certifications marks (check with Christie for latest update): cULus (Canada & US), CE (EU), CCC (China), EAC (Russia), RCM (Australia and New Zealand), India (BIS), Mexico (NOM), Saudi Arabia, South Africa			

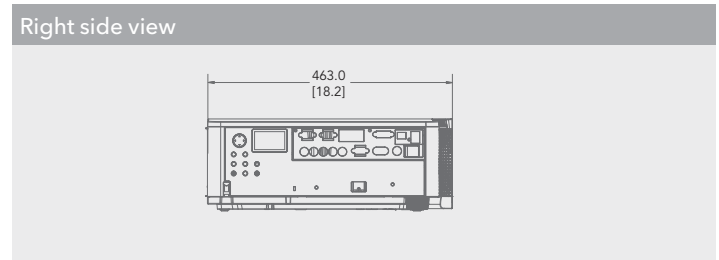
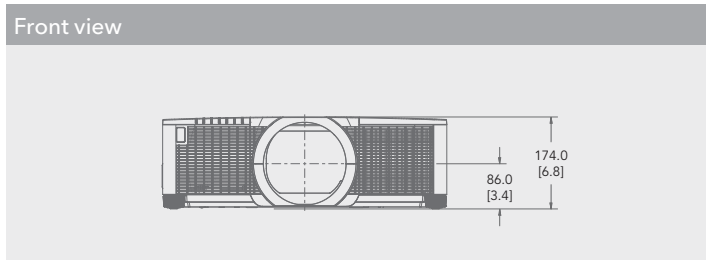

United Kingdom
Branch & EMEA
Head Office
ViewPoint
200 Ashville Way
Wokingham
Berkshire, U.K.
RG41 2PL
PH: +44 (0) 118 977 8000

Middle East
Light Industrial Unit (LIU-17)
Nad Al Shibba
Sheikh Mohammed Bin Zayed Road
Dubai Silicon Oasis
PO Box: 293762
Dubai - U.A.E
PH: +971 (0) 4 503 6800

Africa
Unit C3
Northlands Deco Park
New Market Road
Northriding
Randburg
2164
Johannesburg
Gauteng
South Africa
PH: +27 71 335 8667

Other EMEA offices

Germany
Branch Office
PH: +49 2161 566 200

France
Branch Office
PH: +33 (0) 1 41 21 44 04

Eastern Europe
Representative Office
PH: +36 (0)1 47 48 138

Spain
Branch Office
PH: +34 91 633 9990

Italy
Independent Sales Consultant Office
PH: +39 (0) 2 9902 1161

Russia
Independent Sales Consultant Office
PH: +7 (495) 930-8961



For the most current specification information, please visit www.christieemea.com

Copyright 2015 Christie Digital Systems USA, Inc. All rights reserved. All brand names and product names are trademarks, registered trademarks or tradenames of their respective holders. Christie Digital Systems Canada Inc.'s management system is registered to ISO 9001 and ISO 14001. Performance specifications are typical. Due to constant research, specifications are subject to change without notice.
Printed in Canada on recycled paper. 3983 Dec 14

CHRISTIE®