

Christie Solaria One/ Solaria One+

Alternative/Local content
Digital cinema
High Frame Rate compatible
Post production



One complete digital cinema projection solution. Global appeal.

Investing in a new digital cinema projection system that meets both patron and DCI standards can be a significant investment - especially if distributor-backed financing isn't available. Christie® has created an affordable, DCI compliant, complete solution that will captivate audiences - anywhere in the world. Christie Solaria® One is the brightest-in-class, complete projection solution capable of projecting 8000 lumens in the DCI color space (9000 lumens for alternative content) making it perfect for screens up to 35 feet.

Christie Solaria One comes with a lens, custom-designed Xenon lamp, and Christie Integrated Media Block (IMB) with its own easy-to-operate Screen Management Software (SMS). It's easy to operate and maintain, and has the lowest total cost of ownership on the market.

The Christie Solaria One makes digital cinema conversion affordable, possible - a reality.

CHRISTIE®



- ▲ With a built-in Christie IMB and easy-to-operate SMS, Solaria One is the most reliable, DCI compliant digital cinema projection solution available.

Christie Solaria One

With the ability to display DCI content, alternative and local content, 3D and High Frame Rate (HFR) content, Christie Solaria One gives you the flexibility you've been waiting for. Feature film content is displayed using the built-in Christie IMB, linked directly to external commodity storage systems¹, reducing your overall system cost and increasing overall system reliability. The Christie Solaria One also offers HFR upgrade capabilities and MPEG2/H.264 support for advertising and alternative content. For external alternative content sources, the Christie Solaria One has dual DVI/HDMI inputs, configurable for both 2D and 3D operation.

Christie Solaria One supports all external 3D systems. If you want higher brightness 3D presentations, stack the Christie Solaria One projectors for a stunning 3D presentation.

"The Christie and Solaria One projectors offer superb quality with a heightened viewing experience for movie lovers. These projectors are perfectly suited for smaller screens and are very cost effective. Ster-Kinekor is proud to be the first chain in the world to deploy this product and we believe that this partnership meets the very real demand from our valued audiences in seeing the best film content - at its greatest!"

Fiaz Mahomed
CEO Ster-Kinekor Theatres



Key features:

- S2K DLP Cinema[®]
- Fully DCI compliant
- Xenon illumination
- 3D ready
- High value system design, low cost of ownership
- Integrated Christie IMB and SMS
- Lens and custom-designed high value lamp included
- Touch panel controller with intuitive Graphical User Interface (GUI)
- HFR upgradable
- Uses commodity storage devices¹
- Standard support for HDCP
- MPEG2/H.264 support
- Quick, easy rear access to the lamp
- Washable/reusable filters
- Backed by a single, dedicated technical support team

Christie Solaria One+

For theaters with side masking or post production houses, Christie Solaria One+ offers these additional features:

- Motorized lens mount
- Superior optical performance specifications enabling higher contrast
- Capable of attaining an additional 1000 lumens within the DCI color space



¹ DCI compliant commodity storage systems available through your Christie sales representative.

Christie Solaria One: Brightest in class

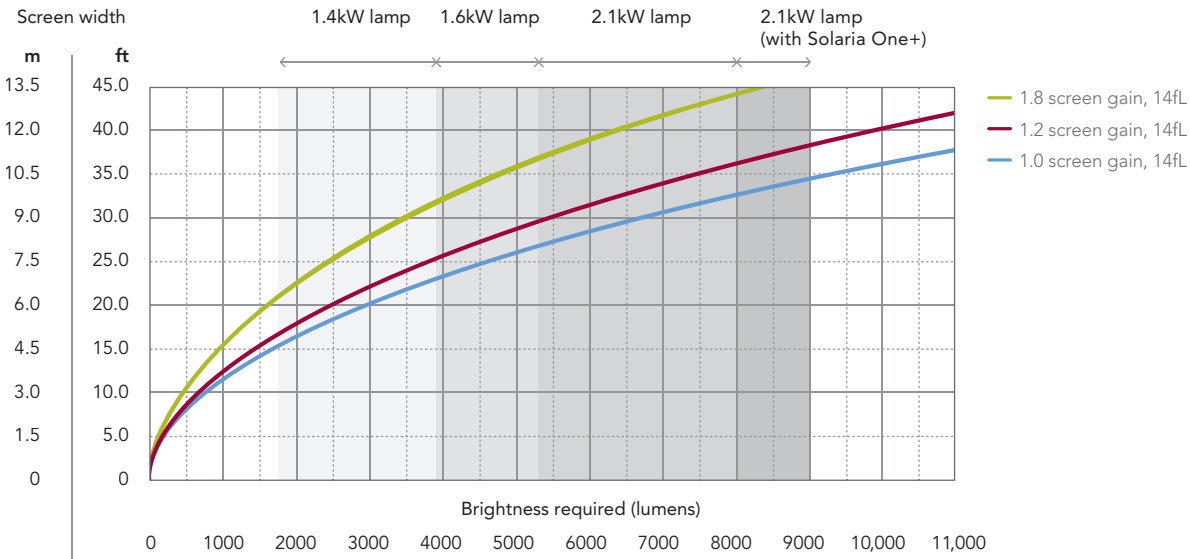

▲ Leveraging three high performing lamp options, the Christie Solaria One and Solaria One+ deliver superior brightness in the DCI color space.

Specifications	Solaria One (138-001102-01)	Solaria One+ (138-001113-01)
Brightness	lamp	<ul style="list-style-type: none"> 2.1kW CDXL-21S1 (003-004258-01) 1.6kW CDXL-16M (003-003900-01) 1.4kW CDXL-14M (003-003066-01)
	nominal	<ul style="list-style-type: none"> 8000 lumens with DCI color space 9000 with native color space
	screen size	<35ft/10.5m maximum screen size
Ballast	2.3kW Ushio (700W-2.1kW)	2.3kW Ushio (700W-2.3kW)
Contrast ratio	>1700:1 full field on/off	>1900:1 full field on/off
Digital micromirror device	<ul style="list-style-type: none"> 0.69" S2K 3-chip DMD DLP Cinema 2048 x 1080 pixels 	
Number of colors	35.2 trillion	
Lens mount configuration	Manual alignment adjustments	Motorized alignment adjustments
Lenses	<ul style="list-style-type: none"> 1.2-1.72:1 (108-458108-01) 1.33-2.1:1 (108-459109-01) 1.62-2.7:1 (108-460101-01) 2.09-3.9:1 (108-461102-01) 	<ul style="list-style-type: none"> 1.2-1.7:1 (108-464105-01) 1.34-1.9:1 (108-465106-01) 1.5-2.15:1 (108-466107-01) 1.7-2.55:1 (108-467108-01) 2.0-3.9:1 (108-468109-01)
Input line voltage	Single phase 220V	
Power supply	700W-2.1kW low-ripple switch mode lamp power supply	
Weight	As installed: 119lbs (53.75kg)	As installed: ~123lbs (55.79kg)
Size	(LxWxH): 27.4 x 27.1 x 15.6" (697 x 688 x 395 mm)	
Accessories	<ul style="list-style-type: none"> HFR software upgrade 90 degree extraction duct adapter (119-103105-01) Rack mount stand (108-416102-01) 	

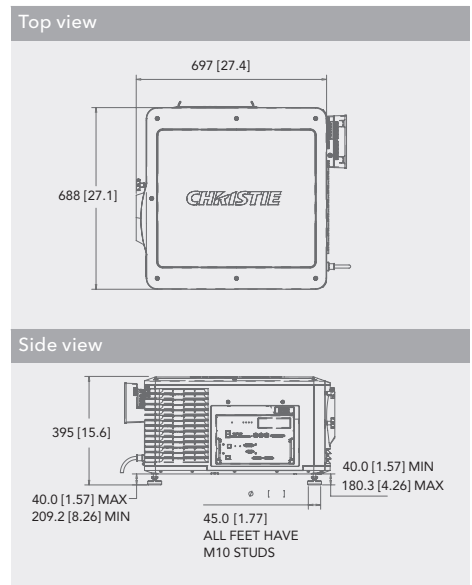

◀ Christie Solaria One shares all the same digital cinema electronics and technologies as the industry-leading Solaria Series, including an easy-to-operate touch panel controller.

▶ With the Christie Solaria One's compact size and optional heat extraction duct adapter, this powerful and feature-rich projector can be installed nearly anywhere.



United Kingdom
Branch & EMEA
Head Office
ViewPoint
200 Ashville Way
Wokingham
Berkshire, U.K.
RG41 2PL
PH: +44 (0) 118 977 8000

Middle East
Light Industrial Unit (LIU-17)
Nad Al Shibba
Sheikh Mohammed Bin Zayed Road
Dubai Silicon Oasis
PO Box: 293762
Dubai - U.A.E
PH: +971 (0) 4 503 6800

Africa
Unit C3
Northlands Deco Park
New Market Road
Northriding
Randburg
2164
Johannesburg
Gauteng
South Africa
PH: +27 71 335 8667

Other EMEA offices

Germany
Branch Office
PH: +49 2161 566 200

France
Branch Office
PH: +33 (0) 1 41 21 44 04

Eastern Europe
Representative Office
PH: +36 (0)1 47 48 138

Spain
Branch Office
PH: +34 91 633 9990

Italy
Independent Sales Consultant Office
PH: +39 (0) 2 9902 1161

Russia
Independent Sales Consultant Office
PH: +7 (495) 930-8961



For the most current specification information, please visit www.christieemea.com

Copyright 2016 Christie Digital Systems USA, Inc. All rights reserved. All brand names and product names are trademarks, registered trademarks or tradenames of their respective holders. Christie Digital Systems Canada Inc.'s management system is registered to ISO 9001 and ISO 14001. Performance specifications are typical. Due to constant research, specifications are subject to change without notice.
Printed in Canada on recycled paper. 3530 Mar 13

CHRISTIE®