

The top half of the page features a complex, abstract pattern of overlapping, semi-transparent blue triangles and polygons. The colors range from light sky blue to deep navy blue, creating a sense of depth and movement. The pattern is contained within a white, curved shape that tapers towards the bottom left corner.

## Installation Guide

020-101374-03

# **D4KLH60 Mirage 4KLH**

**CHRISTIE®**

## NOTICES

### COPYRIGHT AND TRADEMARKS

Copyright ©2019 Christie Digital Systems USA Inc. All rights reserved.

All brand names and product names are trademarks, registered trademarks or trade names of their respective holders.

### GENERAL

Every effort has been made to ensure accuracy, however in some cases changes in the products or availability could occur which may not be reflected in this document. Christie reserves the right to make changes to specifications at any time without notice. Performance specifications are typical, but may vary depending on conditions beyond Christie's control such as maintenance of the product in proper working conditions. Performance specifications are based on information available at the time of printing. Christie makes no warranty of any kind with regard to this material, including, but not limited to, implied warranties of fitness for a particular purpose. Christie will not be liable for errors contained herein or for incidental or consequential damages in connection with the performance or use of this material. Canadian manufacturing facility is ISO 9001 and 14001 certified.

### WARRANTY

Products are warranted under Christie's standard limited warranty, the complete details of which are available by contacting your Christie dealer or Christie. In addition to the other limitations that may be specified in Christie's standard limited warranty and, to the extent relevant or applicable to your product, the warranty does not cover:

- a. Problems or damage occurring during shipment, in either direction.
- b. Projector lamps (See Christie's separate lamp program policy).
- c. Problems or damage caused by use of a projector lamp beyond the recommended lamp life, or use of a lamp other than a Christie lamp supplied by Christie or an authorized distributor of Christie lamps.
- d. Problems or damage caused by combination of a product with non-Christie equipment, such as distribution systems, cameras, DVD players, etc., or use of a product with any non-Christie interface device.
- e. Problems or damage caused by the use of any lamp, replacement part or component purchased or obtained from an unauthorized distributor of Christie lamps, replacement parts or components including, without limitation, any distributor offering Christie lamps, replacement parts or components through the internet (confirmation of authorized distributors may be obtained from Christie).
- f. Problems or damage caused by misuse, improper power source, accident, fire, flood, lightning, earthquake or other natural disaster.
- g. Problems or damage caused by improper installation/alignment, or by equipment modification, if by other than Christie service personnel or a Christie authorized repair service provider.
- h. Problems or damage caused by use of a product on a motion platform or other movable device where such product has not been designed, modified or approved by Christie for such use.
- i. Problems or damage caused by use of a projector in the presence of an oil-based fog machine or laser-based lighting that is unrelated to the projector.
- j. For LCD projectors, the warranty period specified in the warranty applies only where the LCD projector is in "normal use" which means the LCD projector is not used more than 8 hours a day, 5 days a week.
- k. Except where the product is designed for outdoor use, problems or damage caused by use of the product outdoors unless such product is protected from precipitation or other adverse weather or environmental conditions and the ambient temperature is within the recommended ambient temperature set forth in the specifications for such product.
- l. Defects caused by normal wear and tear or otherwise due to normal aging of a product.

The warranty does not apply to any product where the serial number has been removed or obliterated. The warranty also does not apply to any product sold by a reseller to an end user outside of the country where the reseller is located unless (i) Christie has an office in the country where the end user is located or (ii) the required international warranty fee has been paid.

The warranty does not obligate Christie to provide any on site warranty service at the product site location.

### PREVENTATIVE MAINTENANCE

Preventative maintenance is an important part of the continued and proper operation of your product. Failure to perform maintenance as required, and in accordance with the maintenance schedule specified by Christie, will void the warranty.

### REGULATORY

The product has been tested and found to comply with the limits for a Class A digital device, pursuant to Part 15 of the FCC Rules. These limits are designed to provide reasonable protection against harmful interference when the product is operated in a commercial environment. The product generates, uses, and can radiate radio frequency energy and, if not installed and used in accordance with the instruction manual, may cause harmful interference to radio communications. Operation of the product in a residential area is likely to cause harmful interference in which case the user will be required to correct the interference at the user's own expense.

#### CAN ICES-3 (A) / NMB-3 (A)

이 기기는 업무용 (A 급) 으로 전자파적합등록을 한 기기이오니 판매자 또는 사용자는 이점을 주의하시기 바라며, 가정 외의 지역에서 사용하는 것을 목적으로 합니다.

### Environmental

The product is designed and manufactured with high-quality materials and components that can be recycled and reused. **This symbol**  means that electrical and electronic equipment, at their end-of-life, should be disposed of separately from regular waste. Please dispose of the product appropriately and according to local regulations. In the European Union, there are separate collection systems for used electrical and electronic products. Please help us to conserve the environment we live in!

# Table of Contents

<b>Introduction</b>	<b>7</b>
Christie Laser Projection System components	8
General safety precautions	9
AC power precautions	9
<b>Laser Safety Precautions</b>	<b>10</b>
Laser module laser safety labels	11
LM Rack laser safety labels	13
Projector laser safety labels	14
Laser module status lights	17
LM Rack safety features	18
Projector safety features	19
Nominal ocular hazard distance	20
<b>Installation</b>	<b>22</b>
Prepare the installation site	22
Tools required	22
Site requirements	23
Physical environment	23
External ducting	23
Laser rack power requirements	24
Projector power requirements	25
Minimum clearance requirements	25
Position and set up the laser rack	26
Connect external ducting	27
Install rectifiers and breakers	27
Connect power to the Rack Switch	28
Install Laser Modules	28
Connect the interlock cables to the Laser Modules	30
Connect the power cables	31
Connect Ethernet cables to the Laser Modules	31
Connect fiber optic cables to the Laser Modules	31
Connect the Laser Bank Manager	33
Position the projector	34
Level the projector	34

Install the foot extension rods . . . . .	35
Install the touch panel controller . . . . .	35
Install the lens . . . . .	37
Connect fiber optic cables to the projector . . . . .	37
Connect the interlock to the projector . . . . .	39
Connect the laser rack harness . . . . .	39
Connect the Ethernet cable to the projector . . . . .	39
Set up projectors for 3D . . . . .	40
3D requirements . . . . .	40
Active stereo 3D configuration . . . . .	41
Passive stereo 3D configuration . . . . .	42
3D system timing . . . . .	42
3D input video configurations . . . . .	43
Connect devices to the projector . . . . .	43
Connect a video source via DisplayPort . . . . .	44
Connect a video source via 3G-SDI . . . . .	44
Connect a video source using HDMI . . . . .	45
Connect a video source via DVI . . . . .	46
Four-port input video quadrant mappings . . . . .	46
Connect devices to the 3D sync ports . . . . .	47
Connect a computer or server . . . . .	47
<b>Adjust the Image . . . . .</b>	<b>49</b>
Turn the system on . . . . .	49
Test the interlocks . . . . .	50
Test the key switch . . . . .	50
Test the Laser Rack emergency stop . . . . .	50
Test the projector emergency stop . . . . .	50
Add the Laser Modules to the system . . . . .	50
Disconnect all but one Laser Modules . . . . .	51
Image adjustments performed with low white light . . . . .	51
Orient the screen image . . . . .	51
Calibrate the lens motors . . . . .	51
Adjust the image to fit the screen . . . . .	51
Adjust the offset . . . . .	52
Adjust the offset with an Intelligent Lens System (ILS) . . . . .	52
Rotate the integrator rod . . . . .	52
Align the fold mirror . . . . .	53
Adjust horizontal boresight . . . . .	53

Adjust vertical boresight . . . . .	54
Image adjustments with full light . . . . .	55
Turn on all Laser Modules . . . . .	56
Adjust horizontal boresight . . . . .	56
Adjust vertical boresight . . . . .	57
Adjust vertical boresight with an ILS . . . . .	58
Calibrate lens motors . . . . .	59
Adjust DMD convergence . . . . .	59
Obtain the white point and brightness . . . . .	65
Save the laser settings . . . . .	66
Add the projector to a network . . . . .	66
Turn system off . . . . .	66
Turn system off in an emergency . . . . .	66
<b>Troubleshooting . . . . .</b>	<b>67</b>
Check the Laser Module status . . . . .	67
Missing focus/zoom warning . . . . .	68
<b>Projector Specifications . . . . .</b>	<b>69</b>
Power requirements . . . . .	69
Signal connectivity . . . . .	70
Signal connectivity . . . . .	71
Physical specifications . . . . .	72
Operating position . . . . .	72
Operating environment . . . . .	73
Non-operating environment . . . . .	73
Projection lens compatibility . . . . .	73
Accessories . . . . .	74
Standard . . . . .	74
Optional . . . . .	74
Third-party accessories . . . . .	74
Replacement air filters . . . . .	74
<b>Laser Module Specifications . . . . .</b>	<b>75</b>
Power requirements. . . . .	75
Physical specifications . . . . .	75
Operating environment . . . . .	76
Non-operating environment . . . . .	76
Accessories . . . . .	76

Included . . . . .	76
Additional . . . . .	76
Optional . . . . .	76
<b>LM Rack Specifications . . . . .</b>	<b>77</b>
Power requirements . . . . .	77
Physical specifications . . . . .	78
LM Rack (Full) . . . . .	78
LM Rack (Half) . . . . .	78
Operating environment . . . . .	79
Non-operating environment . . . . .	79
<b>Regulatory . . . . .</b>	<b>80</b>
Safety . . . . .	80
Laser safety . . . . .	80
Electro-magnetic compatibility . . . . .	80
Environmental . . . . .	80
Certification . . . . .	81
<b>Installation Checklist . . . . .</b>	<b>82</b>

# Introduction

This manual describes how to install and setup the Christie Laser Projection System.

** WARNING**

Failure to comply with the following could result in death or serious injury.

- The components of the Christie Laser Projection System are designed and certified to work together as a unit. Christie components should never be used with third-party components. Use of non-Christie components with Christie systems may pose safety concerns and void your warranty.
- Only Christie qualified installers who are knowledgeable about the hazards associated with laser use, high-voltage and high temperatures generated by the projector are authorized to assemble, install, and service the Christie Laser Projection System.

# Christie Laser Projection System components

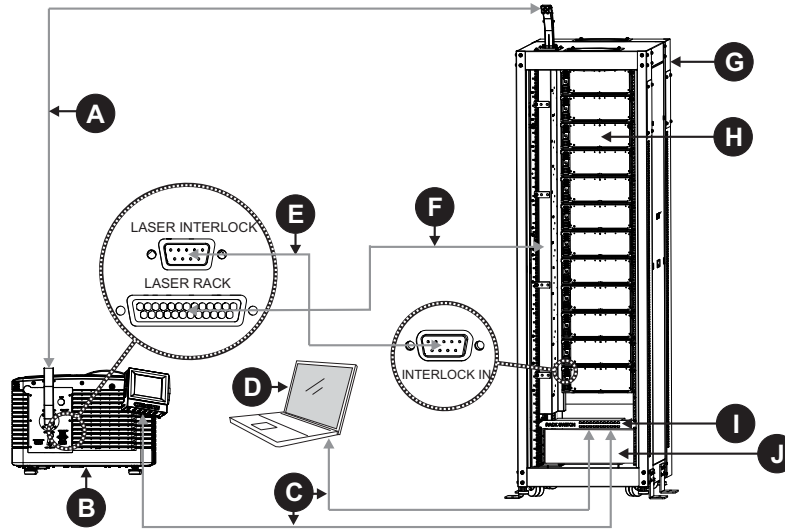

<b>A</b>	Fiber optic bundle Transmits the collected laser light to the projector.
<b>B</b>	Projector Modulates light from the Laser Modules and passes it through a projection lens to produce the image on the screen.
<b>C</b>	Ethernet cables Connects the Laser Bank Manager and the projector to the network.
<b>D</b>	Laser bank manager Runs the Laser Bank Control Application that manages the Laser Modules.
<b>E</b>	Interlock cable (9-pin) Carries the signal for the emergency stop, key switch, and Laser Modules to verify a safe connection between the Laser Modules and the projector.
<b>F</b>	Interlock cable (25-pin) Carries the signal for the Manual Reset button to the projector.
<b>G</b>	LM Rack (Full/Half) (rear side shown) A full and a half rack are available. The LM Rack (Full) (shown) accommodates up to 12 laser modules, the power distribution unit, and the Laser system network switch and equipped with a key switch and an emergency stop for safety. The LM Rack (Half) accommodates up to 7 laser modules.
<b>H</b>	Laser module Generates laser light for the projector.
<b>I</b>	Laser system network switch Provides Ethernet connection to Laser Modules, Laser Bank Manager, and projector.
<b>J</b>	Power distribution unit Contains rectifiers and breakers to provide DC power to Laser Modules.



## General safety precautions

### DANGER

Failure to comply with the following results in death or serious injury.

- An incorrect power setup provides a fire and shock hazard. Do not operate the system unless certified connections, providing the recommended voltage, are used. Do not attempt operation unless the power cord, power socket, and power plug meet the appropriate local rating standards.
- Live power is a shock hazard. Only qualified service technicians are permitted to open a projector enclosure, and only if the AC is fully disconnected.

### WARNING

Failure to comply with the following could result in death or serious injury.

- A qualified technician is required for all installations.
- The projection head must use Christie Laser Modules and laser rack.
- Use of the rear safety strap on the projector is mandatory to prevent the projector from tipping. Secure the strap between the projector and the optional rack stand or another structure.
- Four or more people are required to safely lift and install the projector.
- Two or more people are required to safely lift and install a Laser Module.
- The extremely high brightness of the projector can cause permanent eye damage. For protection from harmful radiation, keep all projector housings intact during operation.
- Never look directly into the projector lens.
- Concentrated light is a fire hazard. Keep hands, clothes, and all combustible material away from the concentrated light beam of the projector.

### CAUTION

Failure to comply with the following could result in minor or moderate injury.

- Wear protective footwear when installing the rack.
- Position all cables where they cannot contact hot surfaces or be pulled or tripped over.

### NOTICE

The Laser Modules and the projector must be operated in an environment that meets the operating range specification. For the Laser Modules, see *Operating environment* on page 80; for the projector, see *Operating environment* on page 77. Failure to comply may result in equipment damage.

## AC power precautions

### WARNING

Failure to comply with the following could result in death or serious injury.

- Loose cables provide a trip or fire hazard. Position all cables where they cannot contact hot surfaces, be pulled, or be tripped over.
- Damaged cables provide a fire hazard. Do not allow anything to rest on the power cord. Never operate the projector if a cable appears damaged.
- Overloaded power outlets and extension cords provide a fire and shock hazard. Do not overload power outlets or extension cords.
- Some attachments and accessories provide a fire, shock, or personal injury hazard. Only use attachments and accessories that are recommended by Christie.

### CAUTION

Only qualified service technicians are permitted to open projector enclosures and only if the projector is disconnected from AC power. Failure to comply could result in minor or moderate injury.

# Laser Safety Precautions

This product is intended for use in a non-cinema environment.

The Christie Laser Projection System components have laser classifications, as outlined by the International Electrotechnical Commission (IEC), ranging from Class 1 to Class 4. Immediate skin hazard and eye hazard can occur from exposure to either the direct or specular reflected beam. This may pose a fire hazard or a diffuse reflection hazard.

- Wavelength: 435 nm to 660 nm
- Beam divergence: 0.1 rad to 0.96 rad, lens dependent
- Pulse pattern: Continuous Wave (CW).
- Maximum output: < 10 W

## DANGER

Failure to comply with the following results in death or serious injury.

- This product must be installed within a restricted access location which is normally inaccessible by the general public, including workers, visitors, and residents in the immediate vicinity, by means of engineering or administrative control measures but is accessible to authorized personnel that have had specific safety training.
- The installation setup must prevent access to the nominal ocular hazard area. See [Projection lens compatibility](#) on page 77.

## WARNING

Failure to comply with the following could result in death or serious injury.

- A qualified technician is required for all installations.
- Never look into the end of a fiber optic cable while the device is operational. Laser radiation can be harmful to the human eye and injury may occur.
- Invisible infrared LED radiation might be emitted from disconnected fibers or connectors. Do not stare into beams or view directly with optical instruments.
- Lasers contain a high energy density. These can be dangerous for skin tissue as well as pose an electrical, chemical, and non-ionizing radiation hazard.
- Do not operate the Christie Laser Projection System with the laser rack access panels removed.

## CAUTION



Failure to comply with the following could result in minor or moderate injury.

- Turn the laser module breakers off before inspecting the fiber optic cable.
- Use of controls or adjustments or performance of procedures other than those specified herein may result in hazardous radiation exposure.

# Laser module laser safety labels

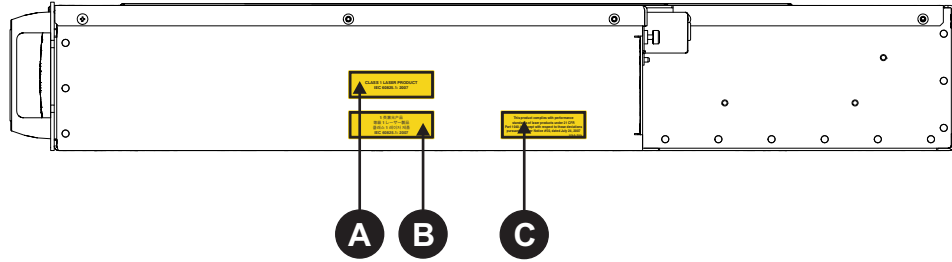
This diagram shows the laser safety labels on the right side of the Laser Module.

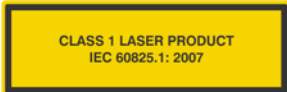

<p><b>A</b></p>		<p>CLASS 1 LASER PRODUCT IEC630825-1: 2007</p>
<p><b>B</b></p>		<p>Translation of label A in French, Chinese, Japanese, and Korean</p>
<p><b>C</b></p>		<p>Christie Digital Systems Canada Inc. 809 Wellington Street North Kitchener, ON N2G 4Y7 Canada</p> <p>This product complies with performance standards of laser products under 21 CFR Part 1040.10 except with those deviations pursuant to Laser Notice #50, dated July 24, 2007</p> <p>U.S.A. Only</p>

This diagram shows labels below the Laser Module cover.



Do not remove the Laser Module cover for maintenance or service. The Laser Module must be repaired at a Christie Digital Factory. Removing the cover voids the warranty. Failure to comply could result in death or serious injury.

- Wavelength: 435 nm to 660 nm
- Beam divergence: 10 mrad
- Pulse Pattern: Continuous Wave
- Maximum power: 64 W

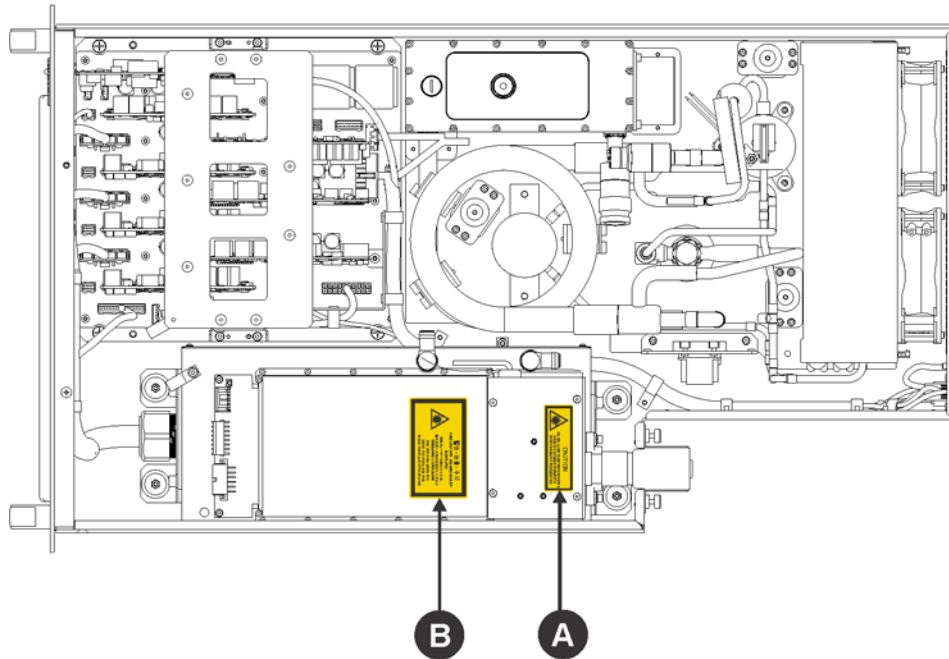

<b>A</b>		<p>CAUTION CLASS 4 LASER RADIATION WHEN OPEN AVOID EYE OR SKIN EXPOSURE TO DIRECT OR SCATTERED RADIATION</p>
<b>B</b>		<p>Translation of label A in French, Chinese, Japanese, and Korean</p>

# LM Rack laser safety labels

This diagram identifies laser safety labels on the laser rack underneath the operator side door.



The laser rack contains a Class 3B laser product. Do not disassemble components in the laser rack. Disassembling components voids the warranty. Failure to comply result in death or serious injury.

- Wavelength: 435 nm to 660 nm
- Beam divergence: 260 mrad
- Pulse Pattern: Continuous Wave
- Maximum power: 100 mW

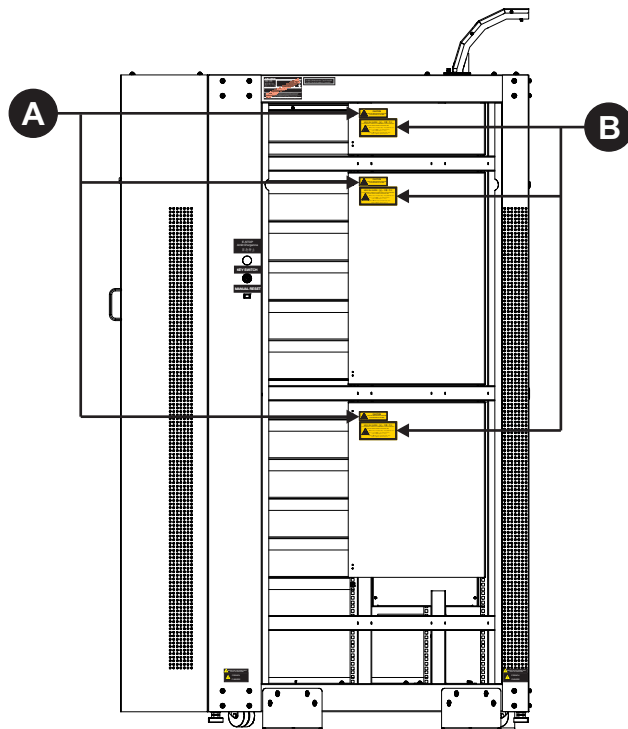

<p><b>A</b></p>		<p>CAUTION CLASS 3B LASER RADIATION WHEN OPEN AVOID EXPOSURE TO BEAM</p>
<p><b>B</b></p>		<p>Translation of label A in French, Chinese, Japanese, and Korean</p>

# Projector laser safety labels

This diagram shows the laser safety labels on the operator side of the projector.

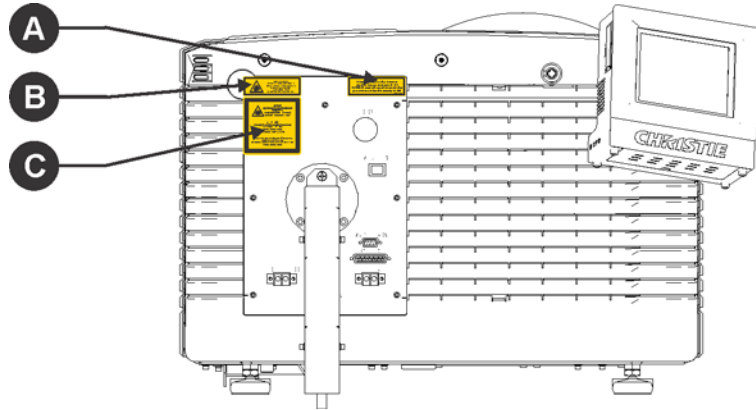

<p><b>A</b></p>		<p>Christie Digital Systems Canada Inc. 809 Wellington Street North Kitchener, ON N2G 4Y7 Canada</p> <p>This product complies with performance standards of laser products under 21 CFR Part 1040.10 except with respect to those deviations pursuant to Laser Notice #50, dated July 24, 2007 U.S.A. Only</p>
<p><b>B</b></p>		<p>LASER RADIATION AVOID EYE OR SKIN EXPOSURE TO DIRECT OR SCATTERED RADIATIONS CLASS 4 LASER PRODUCT 435nm-660nm &lt;10W CLASSIFIED PER IEC 60825-1 2007</p>
<p><b>C</b></p>		<p>Translation of label B in French, Chinese, Japanese, and Korean</p>

This diagram shows the laser safety labels on the lens side of the projector.

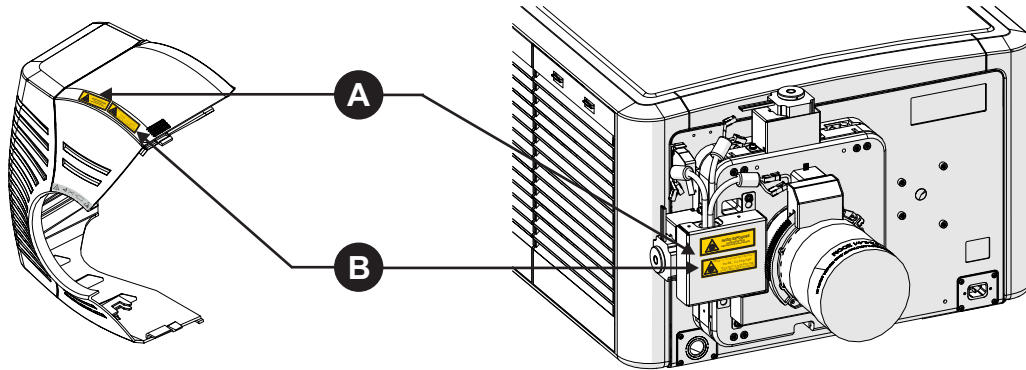

<p><b>A</b></p>		<p>AVOID EXPOSURE LASER RADIATION IS EMITTED FROM THIS APERTURE</p>
<p><b>B</b></p>		<p>Translation of label A in French, Chinese, Japanese, and Korean</p>

This diagram shows the laser safety labels that appear on the fiber bundle relay optics.



**WARNING** Do not remove the protective housing. Failure to comply could result in death or serious injury.

- Wavelength: 435 nm to 660 nm
- Beam divergence: 260 mrad
- Pulse Pattern: Continuous Wave
- Maximum power: 775 W

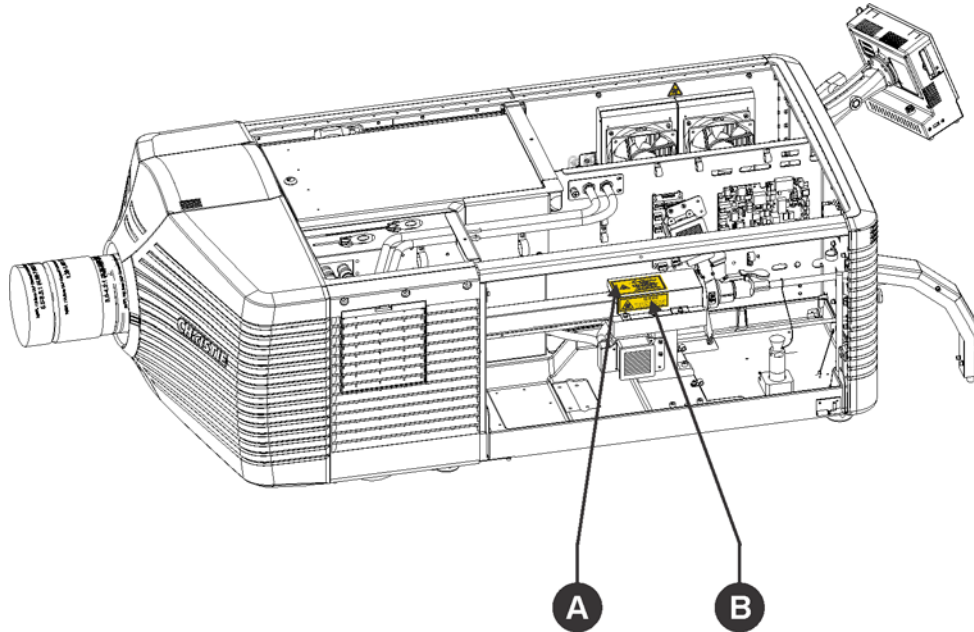

<p><b>A</b></p>		<p>CAUTION CLASS 4 LASER RADIATION WHEN OPEN AVOID EYE OR SKIN EXPOSURE TO DIRECT OR SCATTERED RADIATION</p>
<p><b>B</b></p>		<p>Translation of label A in French, Chinese, Japanese, and Korean</p>



## Laser module status lights

This diagram shows the location of the Laser Module LED status lights. The Laser Module is off when the Power LEDs are off.

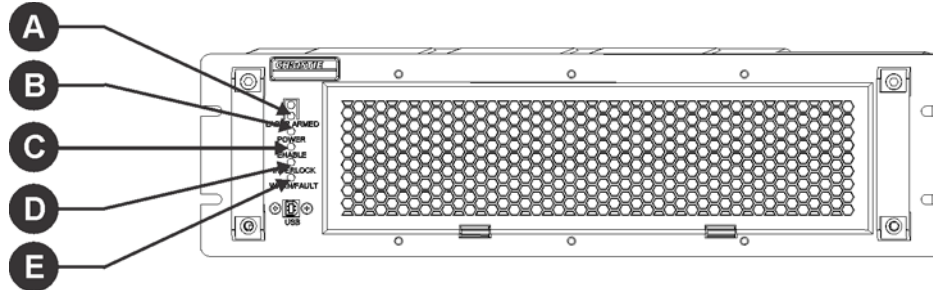

LED	Red	Green	Amber	White
<b>A</b> LASER ARMED				Armed (Interlocks OK, lasers are charged; may or may not be emitting)
<b>B</b> POWER		On (lasers are active and emitting)	Standby (Chiller and fans running)	
<b>C</b> ENABLE				Lasers are active and emitting
<b>D</b> INTERLOCK	Not blinking: external interlock failure Blinking: IR interlock failure	OK		
<b>E</b> WARN/FAULT	Fault (Laser Module does not turn on or has turned off)	No fault	Warning (Laser Module is on but a laser temperature or voltage is above the warning threshold)	

## LM Rack safety features

This diagram shows the laser safety features on the operator side of the laser rack.

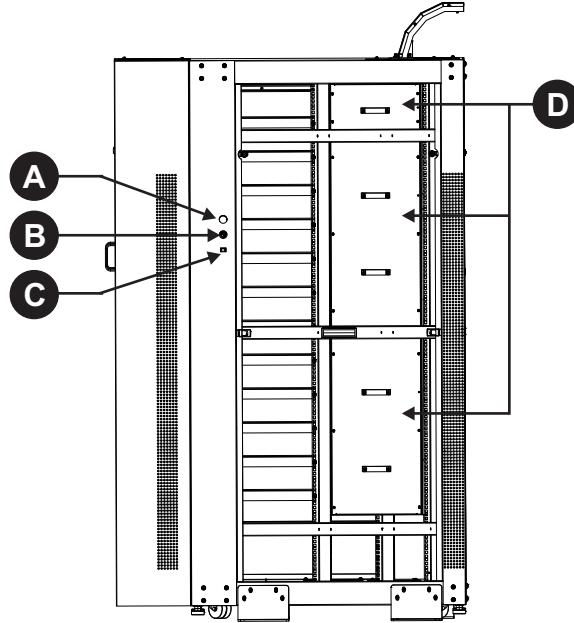

<b>A</b>	Emergency stop To shut down the Laser Modules in an emergency, press <b>E-stop</b> .
<b>B</b>	Key switch Key must be present for the system to run. Laser radiation is not accessible when the key is removed.
<b>C</b>	Manual reset Press <b>Reset</b> following a system restart.
<b>D</b>	Fiber carrier panel When any panel is removed, the laser interlock opens and the lasers cannot be armed.

## Projector safety features

This diagram shows the location of the laser safety features on the projector.

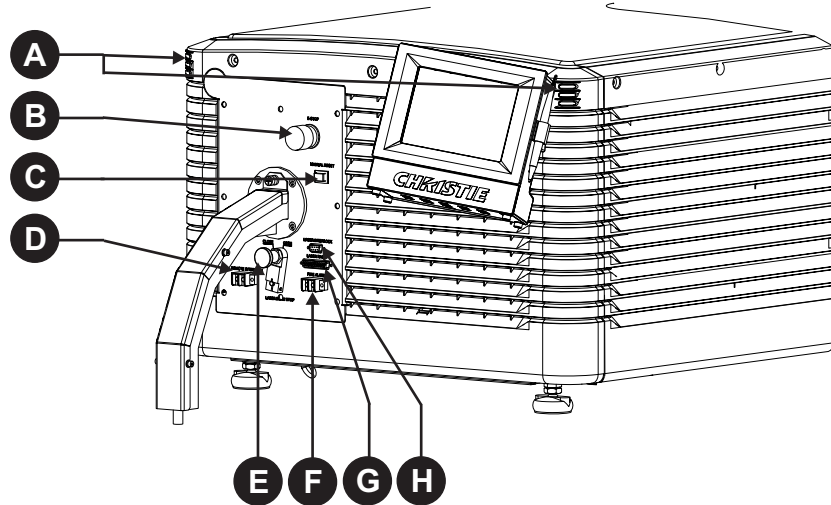

<b>A</b>	Laser emission indicator lights Bottom two LEDs on both sides emit white light when the lasers are armed. They are off when the lasers are not armed.
<b>B</b>	Emergency stop Turns off the Laser Modules off in an emergency.
<b>C</b>	Manual reset Re-arms the system after a system shutdown. Pressing <b>Manual Reset</b> indicates it is safe to arm the lasers.
<b>D</b>	Remote interlock Enables remote shutdown of the projector (optional).
<b>E</b>	Laser beam stop Blocks the laser light path. Rotate the beam stop to <b>Closed</b> when performing service or maintenance on the projector. The laser projector system cannot be armed when the laser beam stop is closed.
<b>F</b>	Fire alarm Enables the projector to be connected to the facility fire alarm system (optional). When the alarm is activated, the Laser Modules turn off.
<b>G</b>	LM Rack (interlock) Connects the projector to the laser rack.
<b>H</b>	Laser interlock Connects the projector to the Laser Modules. When the interlock is tripped, accessible radiation is reduced below the maximum permissible exposure (MPE) level.

## Nominal ocular hazard distance



The installation setup must prevent access to the nominal ocular hazard area. Failure to comply results in death or serious injury.

The nominal ocular hazard distance (NOHD) is the distance from the projector where the light exceeds the maximum permissible exposure (MPE) on the eye and eye injuries can occur. The Skin Nominal Hazard Zone (SNHZ) is the area where skin burns are possible. This diagram illustrates the typical SNHZ (A), the NOHD (A + B), and the area (C) that is within permissible limits:

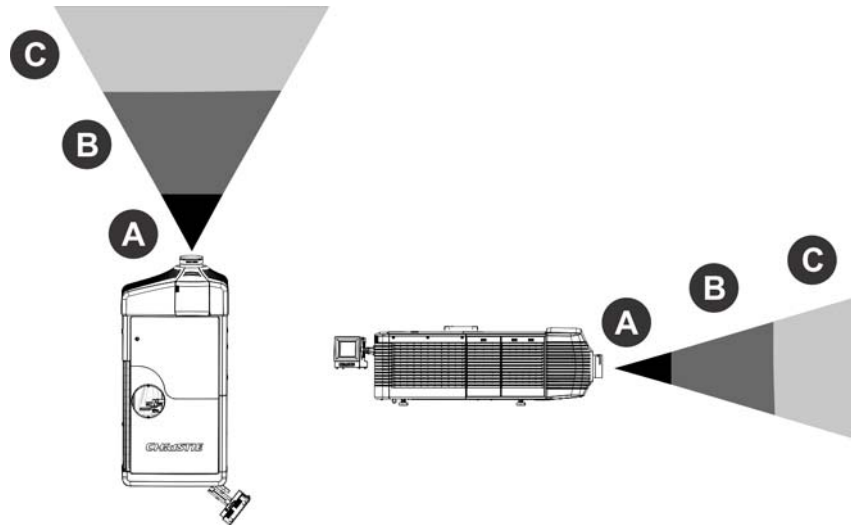

Hazard calculations are dependent on the number of light modules and the lens installed. This table lists hazard distances for Christie projector lenses with the zoom adjusted to its most hazardous position. Contact Christie support for assistance calculating hazard distances specific to your installation.

Light Modules	Projection Lens	4K Throw Ratio	Extended Source NOHD (m)	Skin NHZ (m)
7	0.8:1 (2K)/0.72:1 (4K) (113-104106-XX)	0.72	0.95	0.3
12	0.8:1 (2K)/0.73:1 (4K) (113-104106-XX)	0.72	1.6	0.35
7	1:1 (2K)/0.9:1 (4K) (38-809071-XX)	0.9	1.15	0.35
12	1:1 (2K)/0.9:1 (4K) (38-809071-XX)	0.9	1.95	0.45
7	1.25-1.45:1 (2K) / 1.13-1.31:1 (4K) (129-104106-XX)	1.31	1.65	0.5
12	1.25-1.45:1 (2K) / 1.13-1.31:1 (4K) (129-104106-XX)	1.31	2.8	0.65
7	1.45-1.8:1 (2K) / 1.31-1.63:1 (4K) (129-105107-XX)	1.63	2.05	0.6
12	1.45-1.8:1 (2K) / 1.31-1.63:1 (4K) (129-105107-XX)	1.63	3.5	0.8
7	1.8-2.4:1 (2K) / 1.63-2.17:1 (4K) (129-106108-XX)	2.17	2.7	0.8
12	1.8-2.4:1 (2K) / 1.63-2.17:1 (4K) (129-106108-XX)	2.17	4.6	1.05

Light Modules	Projection Lens	4K Throw Ratio	Extended Source NOHD (m)	Skin NHZ (m)
7	2.2-3.0:1 (2K) / 1.99-2.715:1 (4K) (129-107109-XX)	2.715	3.35	1
12	2.2-3.0:1 (2K) / 1.99-2.715:1 (4K) (129-107109-XX)	2.715	5.75	1.3
7	3.0-4.3:1 (2K) / 2.715-3.89:1 (4K) (129-108100-XX)	3.89	4.8	1.4
12	3.0-4.3:1 (2K) / 2.715-3.89:1 (4K) (129-108100-XX)	3.89	8.2	1.85
7	4.3-6.0:1 (2K) / 3.89-5.43:1 (4K) (129-109101-XX)	5.43	6.65	2
12	4.3-6.0:1 (2K) / 3.89-5.43:1 (4K) (129-109101-XX)	5.43	11.4	2.6
7	5.5-8.5:1 (2K) / 4.98-7.69:1 (4K) (129-110103-XX)	7.69	9.4	2.8
12	5.5-8.5:1 (2K) / 4.98-7.69:1 (4K) (129-110103-XX)	7.69	16.1	3.65

# Installation



Failure to comply with the following results in death or serious injury.

- This product must be installed within a restricted access location which is normally inaccessible by the general public, including workers, visitors and residents in the immediate vicinity, by means of engineering or administrative control measures but is accessible to authorized personnel that may not have specific safety training.
- The installation setup must prevent access to the nominal ocular hazard area. See [Projection lens compatibility](#) on page 77.

## Prepare the installation site

1. Clear the installation area.
2. Post laser hazard warning signs at all entry doors.
3. Place each component near its installation location.

## Tools required

- 12 in. screwdrivers: Phillips #2 (magnetic) and flat
- 2.5mm, 3mm, and 5mm hex drivers
- Adjustable wrench
- Step stool
- Powder-free N-DEX gloves
- Clean dry air (CDA)
- Isopropyl alcohol
- cotton swabs
- Fiber optic microscope (for example, THORLABS FS200)

## Site requirements

This section lists the requirements for a successful installation.

### Physical environment

#### NOTICE

Do not install any portion of the fiber bundle next to a heat source. Failure to comply may result in equipment damage.

These requirements apply to all Christie Laser Projection System components.

- Maximum ambient temperature (operating): 25 °C (95 °F)
- Minimum ambient temperature (operating): 10 °C (50 °F)
- Humidity: 20 % to 80 % maximum
- Altitude: 0 to 2000 meters (0 to 6562 feet)

### External ducting

Sufficient ventilation is required around the laser rack to regulate the temperature of the Laser Modules. See the following chart for airflow and heat load requirements. If necessary, air intake and exhaust HVAC ducts can be installed. See [Connect external ducting](#) on page 27.

#### NOTICE

Add 15% more CFM to the airflow values in the chart for every 1000M above sea level. Failure to comply may result in equipment damage.

Number of Laser Modules	Airflow (CFM) 0 - 1000 m elevation*	Heat Load (kw)
2	260	2.4
3	390	3.6
4	520	4.8
5	650	6.0
6	780	7.2
7	910	8.4
8	1040	9.6
9	1170	10.8
10	1300	12.0
11	1430	13.2
12	1560	14.4

## Laser rack power requirements

A certified electrician must complete these and any other electrical installations.

- One single phase (100 - 240) VAC, 15 A, (50 - 60) Hz or other suitably rated branch circuit for the rack switch.
- One to four single phase (for the LM Rack Full) or one to three single phase (for the LM Rack Half) (200 - 240) VAC, 30 A, (50 - 60) Hz circuits for the power distribution unit, as specified in the following table. To protect from overcurrents, short circuits, and earth faults, a 30 A circuit breaker for each circuit, which must be part of the building installation. The disconnect device must be readily accessible in the same room as the laser rack.
  - Use wires suitable for at least 90 degrees Celsius for AC supply connections.
  - Use appropriately rated IEC 60309 plugs and receptacles as part of the AC power cord connections.
  - Connect the AC feed to the AC terminals on the back of the power distribution unit.
  - Separate safety earth terminals are located at the back of the power distribution unit.
  - Keep the ground wire in the laser rack connected.
  - Ensure that all AC power connections comply with local and national electrical codes.

The electrical installation is subject to the approval of all local authorities having jurisdiction.

Number of Laser Modules	2000 W Rectifiers Required for N + 1 Redundancy	Number of (200 - 240) VAC, 30 A Circuits Required
2	3	2
3	3	2
4	4	2
5	4	2
6	5	3
7	5	3
8	6	3
9	6	3
10	7	4
11	7	4
12	8	4



Four circuits is the preferred configuration. If you install fewer circuits, remove the rectifiers that are not connected to the AC power. Rectifiers not connect to AC power emit an audible signal.



## Projector power requirements

- One (100 - 240) VAC, 10 A, (50 - 60) Hz wall outlet.

## Minimum clearance requirements

This diagram indicates the minimum clearance requirements for the laser rack and the projector.

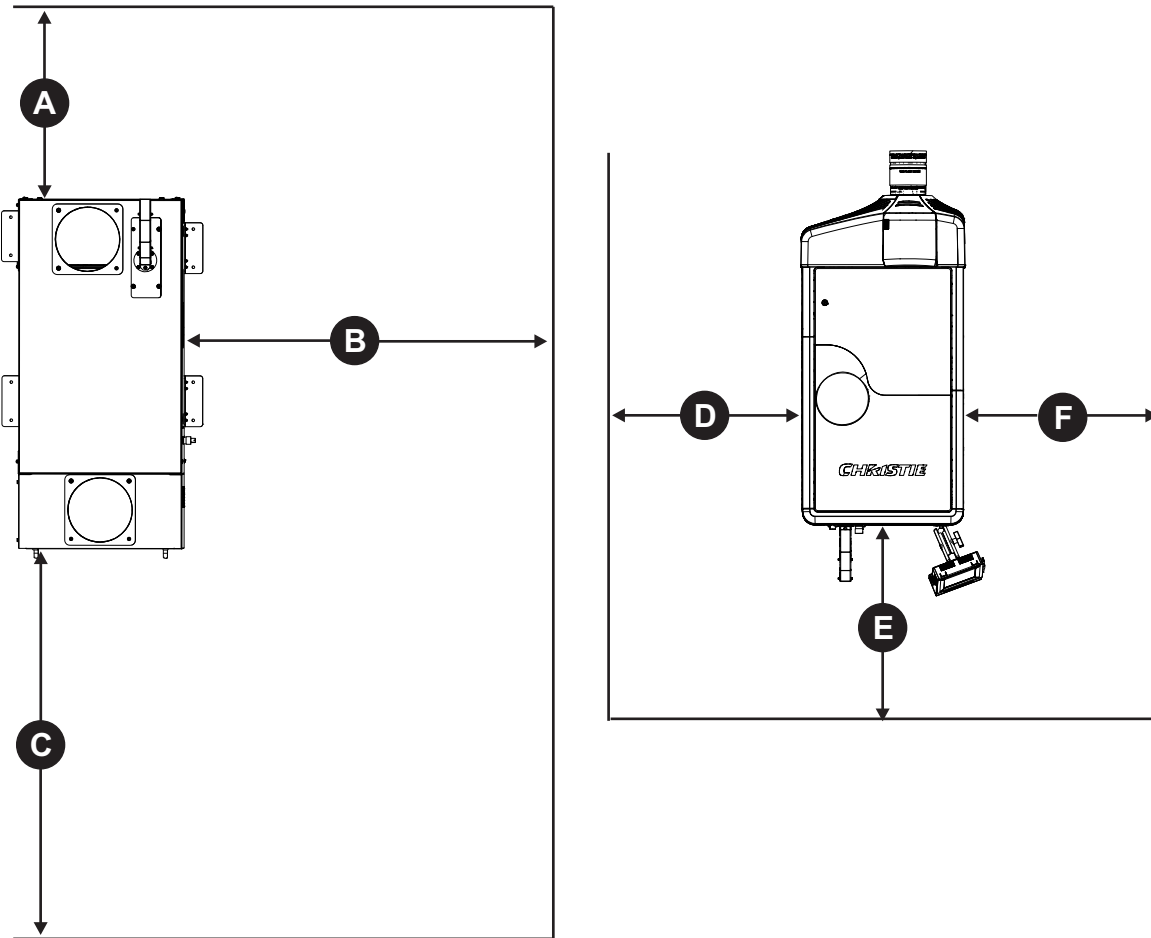

<b>A</b>	500 mm for cable routing at back of the laser rack.
<b>B</b>	900 mm for fiber routing on operator side of the laser rack.
<b>C</b>	1000 mm for removal of the Laser Modules.
<b>D</b>	500 mm for maintenance access.
<b>E</b>	500 mm for fiber safety and touch pad controller access.
<b>F</b>	500 mm for card cage access.

## Position and set up the laser rack

**⚠ WARNING**

Failure to comply with the following could result in death or serious injury.

- Two people are required to set up the laser rack.
- Always load the Laser Modules into the laser rack from the bottom up.
- Laser rack must be positioned with the front completely visible and with the operator side (right side when facing the front) accessible.

1. Remove the laser rack from the packaging and stand it upright so the front, back, and operator side are accessible.
2. Move the adjustable feet up and down until the laser rack is level, then lock the feet in position.
3. If required for local building and safety regulations, secure the laser rack to the floor with mounting brackets.
4. Unlock the front and rear access doors with the two security keys provided.
5. Remove each door by tilting it toward you and lifting high enough to clear the locating pins at the bottom of the rack, then set them aside.
6. Remove the three fiber carrier panels on the operator side and set them aside.
7. If you route the fiber optic overhead, remove the four M4 screws securing the top access cover.
8. If you route the fiber optic cable on the floor, remove the four M4 screws securing the bottom access cover.

## Connect external ducting

This illustration shows the three recommended cooling configurations.

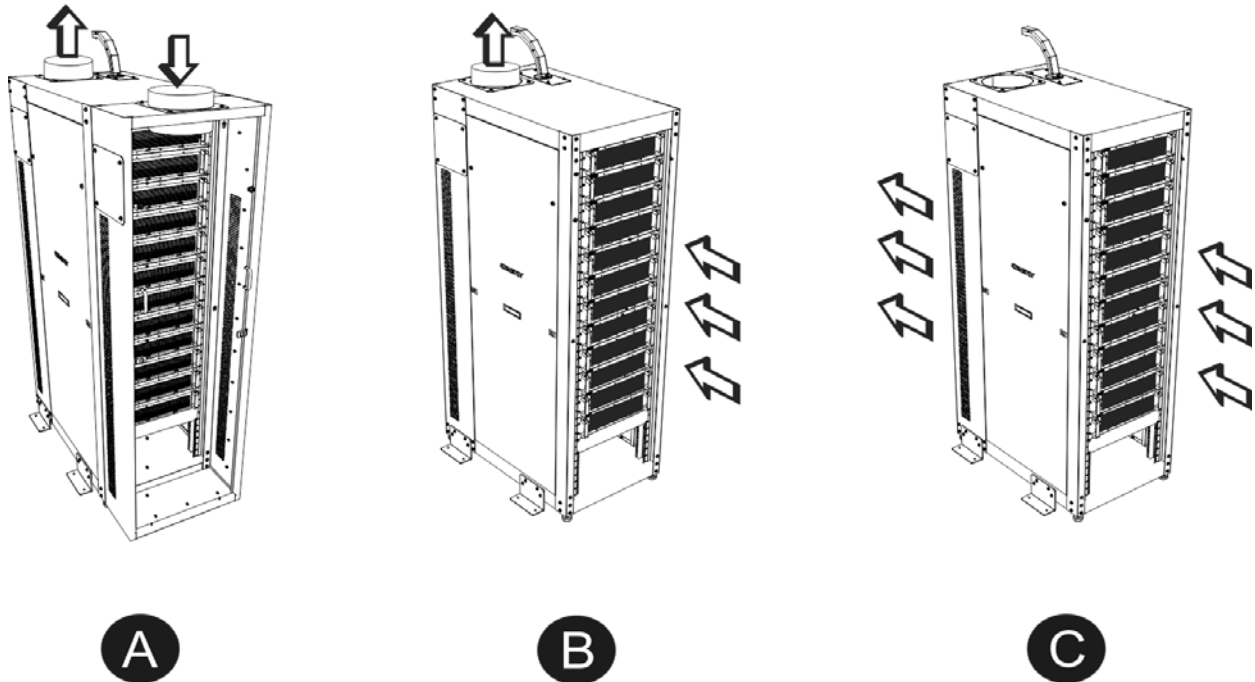

<b>A</b>	Front plenum installed with air intake and exhaust using heating, ventilation, and air conditioning (HVAC) ducts. Any combination of the top and side ducts can be used.
<b>B</b>	Front plenum removed with air intake from room and exhaust using HVAC duct. Top or side exhaust duct can be used.
<b>C</b>	Front plenum and rear door removed with free air flow. One meter of air space behind the laser rack is required. No HVAC system is required.

## Install rectifiers and breakers

A qualified electrician is required to install the single phase (200 - 240) VAC, 30 A, (50 - 60) Hz power lines to the power distribution unit and the wall outlet for the Rack Switch. See [Laser rack power requirements](#) on page 24.

1. At the wall circuit breaker, turn off the power to the laser rack.
2. Insert the rectifiers in the lower section of power distribution unit at the bottom of the laser rack.
3. Turn the breakers to the off position and insert them in the upper section of the power distribution unit.

Each Laser Module has one breaker.

4. Turn on the power to power distribution unit at the wall breaker.

Do not turn on the breakers in the power distribution unit until after the Laser Modules are installed.

5. Verify the rectifier and power distribution unit status lights are on.

## Connect power to the Rack Switch



Turn the Rack Switch on before turning the Laser Modules on, so that the system can find the Laser Modules.

1. Connect the 15 A power line from the wall outlet to the Rack Switch.

## Install Laser Modules



### WARNING

Failure to comply with the following could result in death or serious injury.

- Do not service the Laser Module; the inner compartment contains Class 4 laser light. Maximum power: 64 W, Wavelength: 435 nm–660 nm, Pulse Pattern: Continuous Wave (CW).
- Place each Laser Module in the lowest available slot to maintain stability of the laser rack. If lower slots are skipped, the laser rack becomes top-heavy and could fall.
- Two or more people are required to safely lift a Laser Module.
- The Laser Module is not serviceable. Do not remove covers, use a replacement module instead.

1. Remove the four screws securing the front panel on the bottom slot in the laser rack.

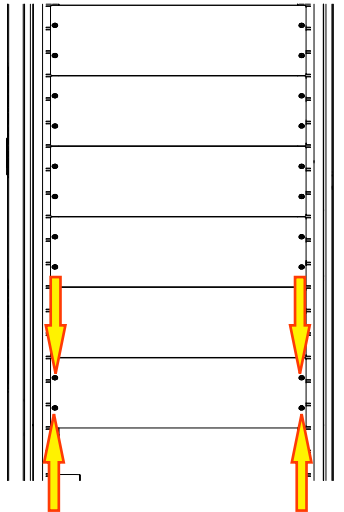

2. Remove the panel and place it in the base of the laser rack.

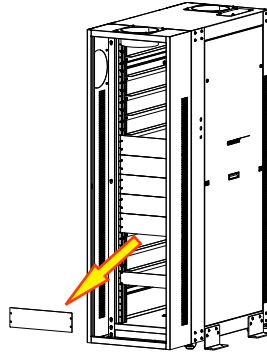

The panels must be kept with the laser rack.

3. Continue removing adjacent panels until there is an open slot for each Laser Module.  
Do not remove more panels than required because they ensure proper airflow throughout the laser rack.
4. Lower the SMA covers for the laser modules:
  - a. Loosen the two screws securing the SMA cover with a 3mm allen key driver.
  - b. Slide the SMA cover down.
  - c. Tighten the screws to secure the SMA cover in position.
5. Keeping the Laser Module level, lift it out of the box.
6. Check the Laser Module for any possible damage that may have occurred during shipping.  
Do not use a damaged Laser Module.
7. Slide the narrow end of the Laser Module into the lowest slot position of the laser rack.  
Always add Laser Modules from the bottom up. Do not skip slots.
8. Secure the Laser Module to the laser rack with the four screws you removed in step 1.
9. Repeat steps 4 to 8 for the remaining Laser Modules.

## Connect the interlock cables to the Laser Modules



The power cables are not connected to the Laser Modules yet.

The Interlock cables are a straight through RS422 connection through D-Sub 9-pin connectors.

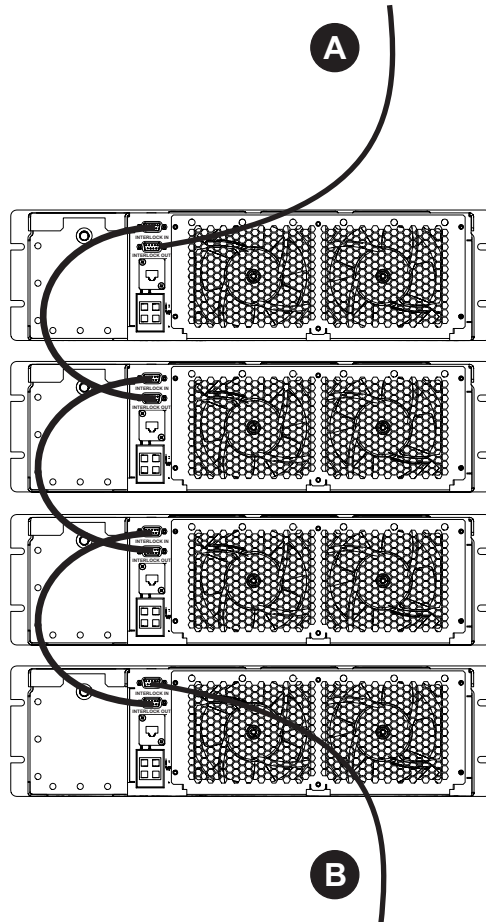

1. Attach the longest cable to the **Interlock IN** connector on the bottom Laser Module.
2. Connect the other end (B) to the projector **Laser Interlock** connector. See [Connect the interlock to the projector](#) on page 39.
3. Attach one end of a 30-centimeter (one-foot) interlock cable (supplied with the laser rack) to the **Interlock OUT** connector on the bottom Laser Module.
4. Attach the other end of the cable to the **Interlock IN** connector on the Laser Module directly above.
5. Repeat steps 3 and 4 to connect the remaining Laser Modules in a daisy chain.
6. Attach the 9-pin wire harness from the laser rack to the **Interlock OUT** connection on the top Laser Module.

7. Ensure every interlock connection is populated.

## Connect the power cables

### ⚠ CAUTION

Turn off the breakers in the power distribution unit to reduce the shock hazard. Failure to comply could result in minor or moderate injury.

1. Turn off the breakers in the power distribution unit at the bottom of the laser rack.
2. Attach a power cable from the power distribution unit to each Laser Module in the laser rack, starting at the bottom.

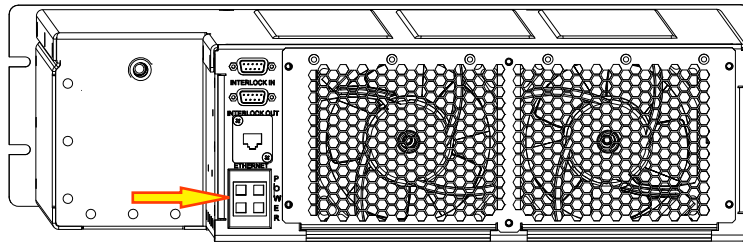

3. Attach a power cable from the wall socket to the Rack Switch.

## Connect Ethernet cables to the Laser Modules

1. Attach a shielded Ethernet cable from the Rack Switch to the Ethernet connector on the back of each Laser Module.

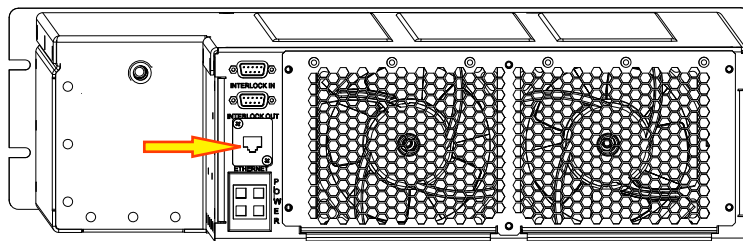

## Connect fiber optic cables to the Laser Modules

This procedure requires a fiberscope.

### ⚠ WARNING

Failure to comply with the following could result in death or serious injury.

- Invisible infrared LED radiation might be emitted from disconnected fibers or connectors. Do not stare into beams or view directly with optical instruments.
- The breakers on the Rack Switch must be off to install the fiber optic cables.
- The key from the laser rack key switch must be removed to install the fiber optic cables.
- The fiber optic cable must be threaded completely. Incorrectly attached cables may result in hazardous radiation exposure.

**NOTICE**

Failure to comply with the following may result in equipment damage.

- Always keep a protective cap on disconnected fiber optic cables.
- Dispose of any used fiber optic cleaning material after use.
- Never touch or blow air from your mouth into the end of a fiber optic cable as it can become contaminated and damaged.
- Bending the cable more than the minimum bend radius of 200 mm (7 <sup>7</sup>/<sub>8</sub> inches) may cause internal breaks.

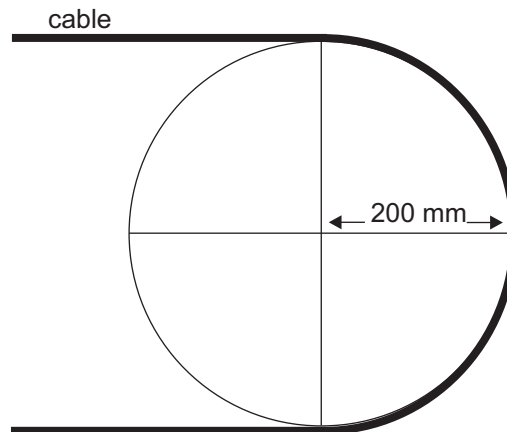

Oil deposits and dust particles on the surface of a fiber optic can cause loss of light or a degraded signal. These contaminants may also transfer into the barrel of the connector they are inserted into. Therefore, you must inspect the fiber optic cables prior to connecting them.

1. Turn off the breakers for the Laser Modules.
2. Remove the key from the laser rack key switch.
3. Remove the four screws securing the fiber optic strain relief cover and set the screws and cover aside.
4. Remove the four screws securing the breakout ferrule and set the screws and ferrule aside.
5. Thread the projector end of the fiber bundle through the fiber optic strain relief from inside of the laser rack to outside, being mindful of the minimum bend radius.
6. Replace the breakout ferrule in the center of the fiber optic strain relief with the four screws removed in step 4.
7. Replace the cover of the fiber optic strain relief with the four screws removed in step 3.
8. Carefully untangle the individual fiber optic cables.
9. Remove the circular, black cap protecting the Laser Module SMA termination point on the top Laser Module.
10. Remove the tethered end cap from the fiber optic SMA connector.
11. Using a fiberscope, inspect the end of the fiber optic connector.
12. If it is dirty, blow the surface with a stream of clean dry air (CDA) to dislodge larger, loose, particles.
13. Re-inspect the fiber optic cable.



14. If the fiber end face still appears contaminated, apply some isopropyl alcohol to the tip of a cotton swab and gently wipe the surface.
15. Repeat steps 12 to 14 until the face is clean or the contaminant cannot be removed.
16. If the contaminant cannot be removed replace the fiber optic cable with the spare.
17. If there is no clean spare fiber, contact Christie for possible repair.
18. Route the fiber to the right of the stud, ensuring there is no tight bend or force against the fiber. If the bend is too tight, place the fiber above the stud.
19. Remove the red, protective end cap from the Laser Module SMA termination point.
20. Taking care not to touch the glass end of the fiber optic cable to anything, gently slide the connector all the way into the Laser Module SMA termination point until it stops.

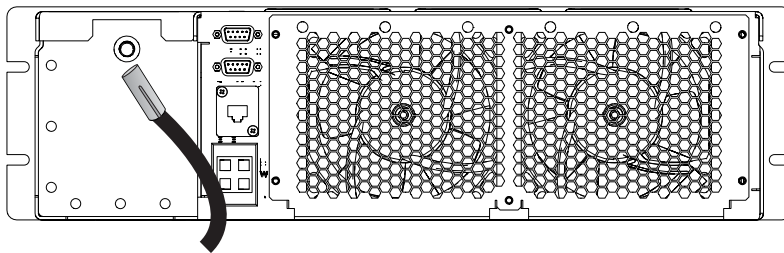

21. Finger-tighten the coupler to secure the fiber optic connection.
22. Attach the red end cap from the Laser Module to the tethered fiber cable end cap.
23. Repeat steps 9 to 22 for each Laser Module.
24. Raise each lowered LOS cover and tighten the two screws securing it.
25. Replace the three fiber carrier panels.
26. Replace the operator side door by placing the bottom of the door on the locating pins and push it until it is vertical and the two tabs on the sides slide into place.
27. Replace the key in the laser rack key switch.

## Connect the Laser Bank Manager

The Laser Bank Manager is normally a laptop with Windows 7 operating system or later. It runs the Laser Bank Control Application that controls the light levels in each Laser Module.

1. Connect one end of a shielded Ethernet cable (provided) to any open port on the Rack Switch.
2. Connect the other end of the Ethernet cable to the Laser Bank Manager.
3. Attach one end of the power cable to the wall socket and the other to the Laser Bank Manager socket.

## Position the projector

### ⚠ WARNING

Four or more people are required to safely lift and install the projector. Failure to comply could result in death or serious injury.



Keep the projector lens as parallel to the screen as possible, even if significantly above the screen center. When a particularly short throw distance combines with a wide screen, you may have to forfeit some aim and stay more parallel to the screen. In such cases, some lens offset can reduce the keystone distortion.

1. If installing the projector in the optional rack stand (P/N 108-282101-02), follow the instructions provided with the rack stand to install it.
2. Position the projector at an appropriate throw distance, centered and parallel with the theater screen. If not possible, aim the projector slightly off-center and use lens offset to center the image on the screen.
3. Secure one end of the rear safety strap to the projector.
4. Secure the other end to the strap to the optional rack stand or another structure.
5. Attach one end of the power cable to the wall socket and the other to the projector socket.

## Level the projector

### ⚠ WARNING

Use of the rear safety strap on the projector is mandatory to prevent the projector from tipping. Secure the strap between the projector and the optional rack stand or another structure. Failure to comply could result in death or serious injury.

### NOTICE

The front-to-back and side-to-side tilt of the projector must be within the supported ranges. See *Operating position* on page 76. This limit ensures the proper positioning of the liquid cooling reservoir. Failure to comply may result in equipment or property damage.

1. Loosen the projector feet lock nuts using an adjustable wrench.
2. Adjust the vertical tilt of the projector by raising or lowering the lens-side feet in tandem and by raising or lowering the operator-side feet in tandem.

Turn the adjustable feet on the bottom of the projector clockwise or counter-clockwise 1/8th of a turn at a time to extend or retract them.

When two or more feet are adjusted at once, always adjust them the same amount. This keeps equal weight distribution on all feet for stability.

3. Adjust the horizontal tilt of the projector by raising and lowering the left-side feet in tandem and the by raising or lowering the right-side feet in tandem.
4. Verify that the image is centered and parallel with the top of the screen. If additional adjustments are required, repeat steps 1 and 2.

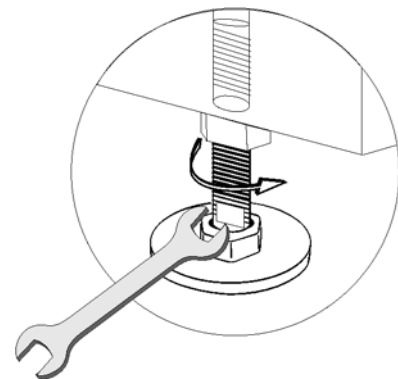

5. If you need to adjust the vertical or horizontal position more than the feet allow, install the foot extension rods. See *Install the foot extension rods* on page 35.
6. Tighten the projector feet lock nuts.

Adjust lens offset, rather than extra projector tilt, if vignetting is not observed.

## Install the foot extension rods



### WARNING

Failure to comply with the following could result in death or serious injury.

- Use of the rear safety strap on the projector is mandatory to prevent the projector from tipping. Secure the strap between the projector and the optional rack stand or another structure.
- Two people are needed to safely perform this procedure.

If you need to adjust the vertical or horizontal position of the projector beyond what the standard feet allow, install the foot extension rods.

1. Prop up the rear of the projector to access the two rear feet.
2. Remove the feet by loosening the lock nut and rotating the each foot out of the projector.
3. Add the extension rods to the standard feet.
4. Thread the extended feet into the projector's baseplate.
5. Adjust the feet until the required tilt is achieved.

Lock the feet in place by turning each lock nut until it fits tight against the projector.

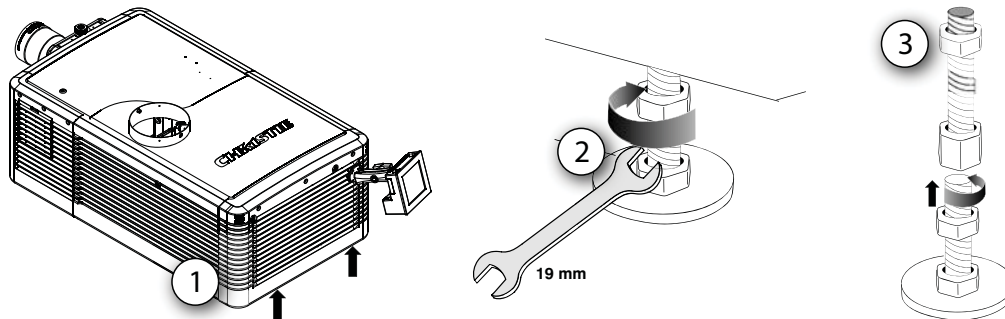

## Install the touch panel controller

Note that the touch panel controller (TPC) supplied with the Christie Laser Projection System is different from the TPC for lamp-based projectors.

1. Loosen the mounting arm on the TPC.

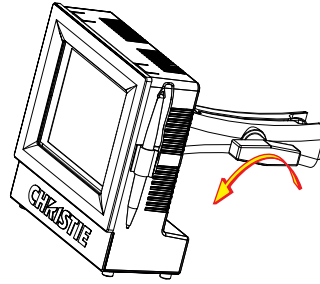

2. Place the base of the TPC mounting arm over the ball joint (A) located on the rear panel of the projector.

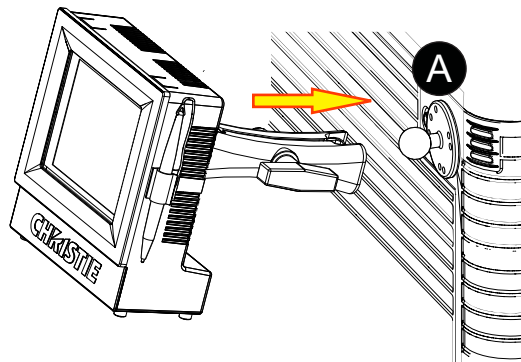

3. Tighten the mounting arm until it fits snugly on the ball joint.

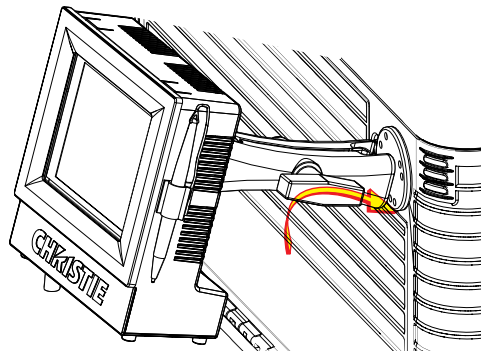

4. Connect the cable from the TPC to the connector on the rear panel of the projector.
5. Tilt the TPC to adjust the viewing angle.

## Install the lens

### CAUTION

Keep fingers and other body parts away from the moving parts in the projector. Motors and fans may start without warning. Tie back long hair, remove jewelry and loose clothing before manually adjusting the projector. Failure to comply could result in minor or moderate injury.

### NOTICE

Failure to comply may result in equipment damage.

- The primary lens seals the projection head, preventing contaminants from entering the main electronics area. Do not operate the projector without a lens installed. Use a lens plug when installing or transporting the projector.
- Lens caps must be removed for operation or they can melt and damage the lens.

1. Make sure the lens locking lever is in the UP position.
2. If attached, remove the rear lens cap from the lens.
3. Slide the lens into the lens mount, aligning all connections

*For lenses with an "UP" label, ensure the "UP" label is in the top position. This practice makes the boresight alignment more consistent each time the lens is replaced.*

4. Secure the lens with the lens locking lever (DOWN position).
5. Calibrate the lens motors.

## Connect fiber optic cables to the projector

### WARNING

Beam stop must be in the **closed** position. Failure to comply could result in death or serious injury.

### NOTICE

Failure to comply with the following may result in equipment damage.

- Connect fiber optic cables to the projector once it is securely positioned.
- Secure the tethered protective end cap to the threaded hole in the base of the projector whenever the fiber optic cable is disconnected.

1. Turn off the Laser Module breakers.
2. Pull the beam stop knob on the projector and rotate it to **closed**.
3. If the fiber optic cable comes from the side or the ceiling, loosen 5 mm hex screws (quantity four) securing the fiber optic stress relief.
4. Rotate the fiber optic stress relief to the correct orientation.

The fiber optic strain relief can be placed in one of four positions: pointing up, down, left, or right.

5. Secure the fiber optic stress relief.
6. Remove the four screws securing the fiber optic strain relief cover and set the screws and cover aside.
7. Remove the four screws securing the breakout ferrule and set the screws and ferrule aside.
8. Unlock and open the Optical Access Door.

9. Thread the fiber optic cable through the strain relief into the projector.
10. Remove the tethered cap from the fiber optic cable.
11. Using a fiberscope, inspect the end of the fiber optic connector.
12. If it is dirty, blow the surface with a stream of clean dry air (CDA) to dislodge larger, loose, particles.
13. Re-inspect the fiber optic cable.
14. If the fiber end face still appears contaminated, apply some isopropyl alcohol to the tip of a cotton swab and gently wipe the surface.
15. Inspect the fiber optic cable again.
16. If it is still dirty, repeat steps 12 to 15 until the end face is clean.
17. Open the dust cover on the fiber receiver.
18. Insert the cable with the dowel pin and dowel hole lined up. Insert the cable all the way in until it stops.

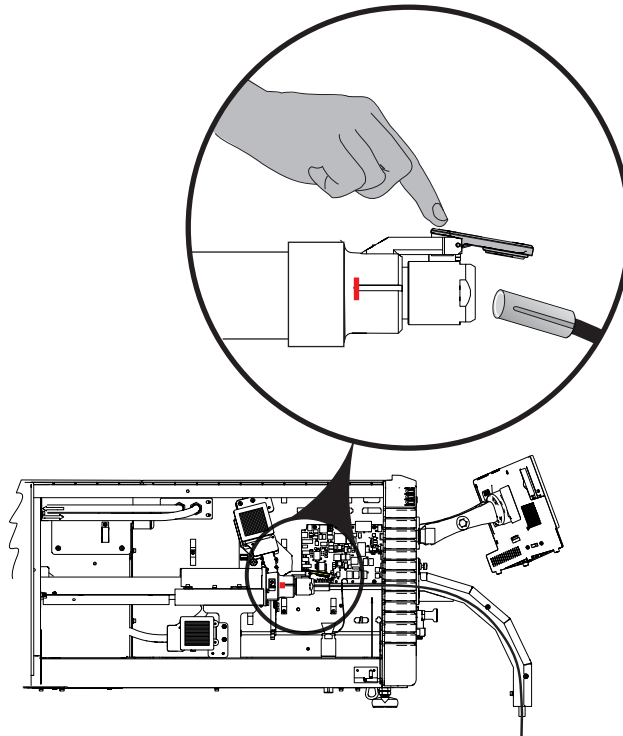

19. Finger-tighten the coupler to secure the fiber optic connection.

20. Attach the tethered end cap from the fiber optic bundle to the threaded hole on the base of the projector.

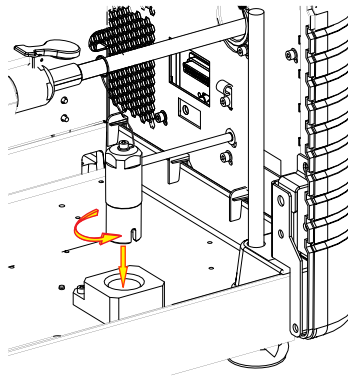

21. Replace the breakout ferrule on the fiber optic strain relief with the four screws removed in step 7.
22. Replace the cover of the fiber optic strain relief with the four screws removed in step 3.
23. Close and lock the Optical Access door.

## Connect the interlock to the projector

1. Attach the female connector of the longest 9-pin Interlock cable to the **Interlock IN** connector of the bottom Laser Module in the laser rack.  
*See [Connect the interlock cables to the Laser Modules](#) on page 30.*
2. Connect the male connector of the cable to the **Laser Interlock** connector at the back of the projector.

## Connect the laser rack harness

1. Connect the 25-pin laser rack harness to the laser rack connector at the back of the projector.

## Connect the Ethernet cable to the projector

1. Remove the bottom cover of the touch pad controller.

2. Connect the Ethernet cable to the connector at the bottom of the TPC.



3. Replace the bottom cover feeding the cable through the opening.

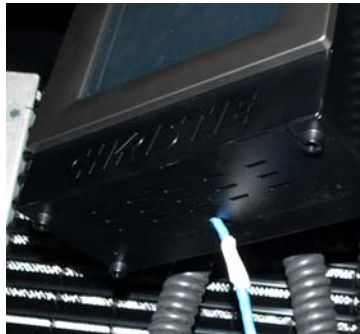

4. Connect the other end of the Ethernet cable to the Rack Switch.

## Set up projectors for 3D

The Mirage projector is capable of displaying stereoscopic 3D video sources, relying on additional hardware (stereo emitters and glasses) to complete the display system.

Images generated from a stereo 3D video source consist of a series of images (frames) that alternate quickly between two slightly different viewpoints, corresponding to our left and right eyes. When these frames are displayed fast enough and viewed with special glasses synchronized to the left/right (L/R) changes, the resulting image appears with the same depth and perspective sense in the real world.



The type of 3D glasses can be active or passive stereo depending on the type of stereo controllers and screen used.

## 3D requirements

Stereo 3D applications require a stereo 3D-capable source, special hardware and software setups, and the projector's 3D Settings menu option to control the projector's processing, synchronization, and displaying of the stereoscopic 3D source material.

### Hardware requirements

Note the following hardware requirements for stereo 3D applications:



- Christie Digital Systems Mirage 4KLH Series projector
  - 3D stereo sync cable (for Direct-Input 3D)
  - A source, usually a computer with a 3D graphics card(s)
  - Emitter for controlling active shutter glasses
- or

A qualified device that mounts in front of the lens of the project to process the light from the lens into a passive polarized light. Contact your Immersive dealer for more information.

## Software and content requirements

Note the following software and content requirements for stereo 3D applications:

- Any 3D computer software application that supports 3D stereo on a supported computer(s) with associated graphic cards (suggested cards include AMD or NVIDIA)
- A video stream from a video source prepared to be sequential content (for Direct-Input 3D) or two video streams from a video source that has been prepared to be supplied left eye and right eye concurrently and frame locked (Dual-Input 3D)

## Active stereo 3D configuration

The following diagram shows the typical hardware configuration for active stereo 3D systems:

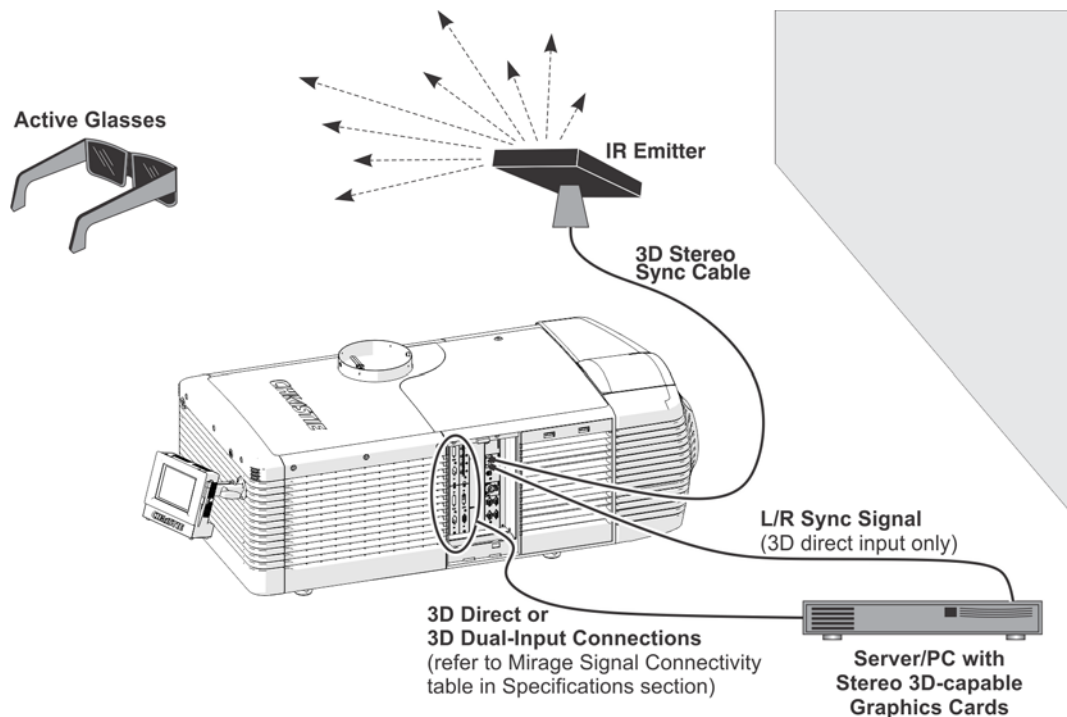

In response to the 3D Sync Out signal from the projector, the IR emitter emits an infrared signal to a receiver in the active 3D shutter glasses. This synchronizes the active glasses to alternatively open and close for the active stereo 3D applications.

## Passive stereo 3D configuration

The following diagram shows the typical hardware configuration for passive stereo 3D systems:

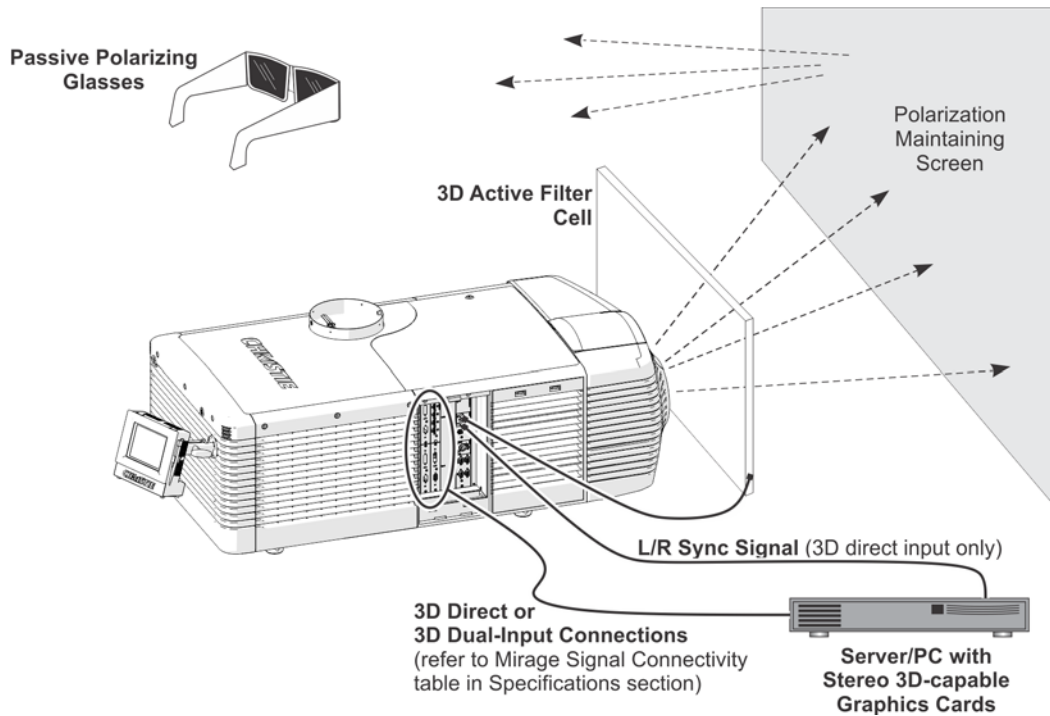

For operation with passive glasses, a 3D polarization filter is placed in front of the lens and is synchronized to the projected frames with the 3D Sync Out signal.

## 3D system timing

Consult the documentation for your glasses or polarization filter and keep their specifications in mind when configuring the projector for 3D operation. The projected video must be optimized for the glasses' shutter speed or polarization filter performance to prevent obvious "ghosting" of the video content (known as cross-talk in stereo 3D applications) or other more subtle color artifacts. Visual performance can be optimized by adjusting the Dark Interval and the 3D Sync Delay settings.

## 3D input video configurations

The stereo 3D input video stream may be supplied from the video server to the projector in two configurations: Direct-Input 3D or Dual-Input 3D.

Configuration	Description
<b>Direct-Input 3D</b>	<p>In this configuration a single video stream is provided by the video server, with the left eye and right eye frames supplied as alternate frames within the video stream. A 3D Input Sync may be used to identify the left eye frames.</p> <p>The Direct-Input 3D video stream may be supplied by either a Four-Port input video configuration (such as four cables each supplying one quadrant of the image) or an One-Port input video configuration (such as one cable supplying the entire frame).</p>
<b>Dual-Input 3D</b>	<p>In this configuration two video streams are provided by the video server, with the left eye supplied by one stream and the right eye supplied by the other. The video streams are frame locked and supplied concurrently.</p> <p>The Dual-Input 3D video streams may be supplied by either two Four-Port input video configurations (such as four cables each supplying one quadrant of the image for each eye, with a total of eight cables) or two One-Port input video configurations (such as one cable supplying the entire frame for each eye, with a total of two cables).</p>

## Connect devices to the projector

1. To access the communication ports, remove the access panel.
2. Route all cables along the channels located on the bottom of the projector and up through the opening in the frame to the communication port.
3. Replace the access panel to ensure server and source connections remain secure.

Input signal devices are connected to the video option cards and communication devices are connected at the MCPU panel.

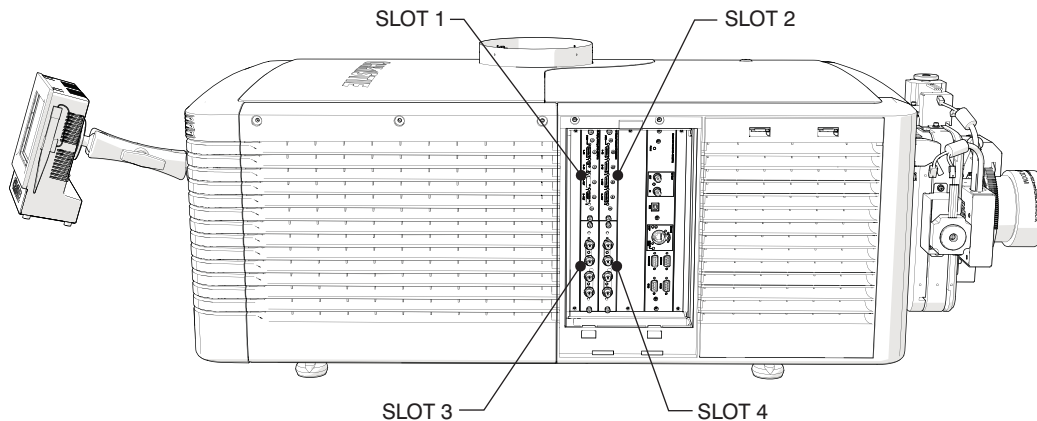

## Connect a video source via DisplayPort

The Twin DisplayPort Input Card (TDPIC) accepts digital video data from the DisplayPort sources. Various input configurations are supported.

Input Configuration	Description	Requirements
<b>Four-Port</b>	Enables connection of four DisplayPort cables to two TDPIC cards (using the 1-IN and 2-IN inputs of two cards in slots 1 and 2, or in slots 3 and 4). Each DisplayPort input supplies one quadrant of a 4K input image. This configuration supports high resolution and high frame rate input video streams, including both 2D and 3D direct inputs.	Two TDPIC cards
<b>Four-Port, Dual-Input 3D</b>	May be used for Dual-Input 3D configurations. For information on the video quadrant mapping for the TDPIC four-point input configuration, see <a href="#">Four-port input video quadrant mappings</a> on page 46.	Four TDPIC cards
Single One-Port	Enables connection of one DisplayPort cable to the 1-IN input of a TDPIC card (any slot). In this configuration the DisplayPort input supplies the entire video raster.	One TDPIC card
<b>One-Port, Dual-Input 3D</b>	May be used for Dual-Input 3D configurations.	One or two TDPIC cards



For limitations of one card use for One-Port Dual-Input 3D, see [Signal connectivity](#) on page 74 and [Signal connectivity](#) on page 75.

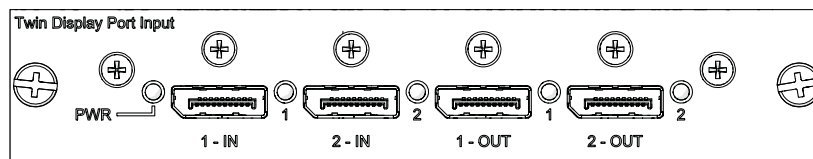

## Connect a video source via 3G-SDI

The 3G Input Card (3GIC) accepts digital video data from HD- and 3G-SDI (Serial Digital Interface) sources. Various input configurations are supported.

Input Configuration	Description	Requirements
<b>Four-Port</b>	Enables connection of four SDI cables to two 3GIC cards (using the 1-IN and 2-IN inputs of two cards in slots 1 and 2, or in slots 3 and 4). Each SDI input supplies one quadrant of a 4K input image. This configuration supports high resolution and high frame rate input video streams, including both 2D and 3D direct inputs.	Two 3GIC cards
<b>Four-Port, Dual-Input 3D</b>	May be used for Dual-Input 3D configurations. For information on the video quadrant mapping for the 3GIC four-point input configuration, see <a href="#">Four-port input video quadrant mappings</a> on page 46.	Four 3GIC cards

Input Configuration	Description	Requirements
Single One-Port	Enables connection of one SDI cable to the 1-IN input of a 3GIC card (in any slot). In this configuration the SDI input supplies the entire video raster.	One 3GIC card
One-Port, Dual-Input 3D	May be used for Dual-Input 3D configurations.	One or two 3GIC cards



3GIC does not support 120 Hz framerate. For limitations of one-card use for One-Port Dual-Input 3D, see [Signal connectivity](#) on page 74 and [Signal connectivity](#) on page 75.

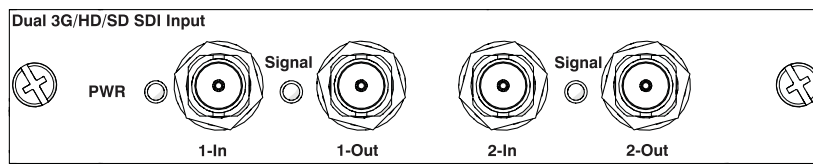

## Connect a video source using HDMI

The Twin HDMI Input Card (THIC) accepts digital video data from HDMI sources. Various configurations are supported.

Input Configuration	Description	Requirements
Four-Port	Enables connection of four HDMI cables to two THIC cards (using the 1-IN and 2-IN inputs of two cards in slots 1 and 2, or in slots 3 and 4). Each HDMI input supplies one quadrant of a 4K input image. This configuration supports high resolution and high frame rate input video streams, including both 2D and 3D direct inputs. Maximum framerate is 60 Hz.	Two THIC cards
Four-Port, Dual-Input 3D	May be used for Dual-Input 3D configurations. For information on the video quadrant mapping for the THIC four-point input configuration, see <a href="#">Four-port input video quadrant mappings</a> on page 46. Maximum framerate is 120 Hz.	Four THIC cards
Single One-Port	Enables connection of one HDMI cable to the 1-IN input of a THIC card (in any slot). In this configuration, the HDMI input supplies the entire video raster. Maximum framerate is 60 Hz.	One THIC card
One-Port, Dual-Input 3D	May be used for Dual-Input 3D configurations. Maximum framerate is 120 Hz.	One or two THIC cards



For limitations of one-card use for One-Port Dual-Input 3D, see [Signal connectivity](#) on page 74 and [Signal connectivity](#) on page 75.

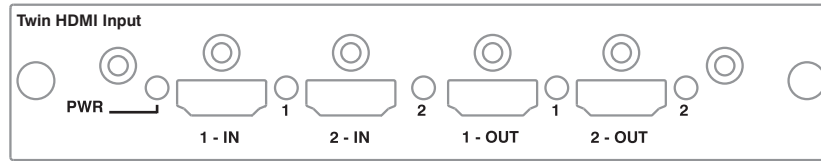

## Connect a video source via DVI

The Dual Link DVI Input Card (DDIC) accepts digital video data from DVI sources. Various input configurations are supported; however, the VGA port is not supported.

Input Configuration	Description	Requirements
Four-Port	Enables connection of four DVI cables to four DDIC cards. Each DVI input supplies one quadrant of a 4K input image. This configuration supports high resolution and high frame rate input video streams.	Four DDIC cards
Single One-Port	Enables connection of one DVI cable to the DVI input of a DDIC card (in any slot). In this configuration, the DVI input supplies the entire video raster.	One DDIC card
One-Port, Dual-Input 3D	May be used for Dual-Input 3D configurations.	Two DDIC cards



Only one Four-Port input configuration is available for DVI inputs. For information on the video quadrant mapping for the DDIC four-point input configuration, see [DDIC card](#) on page 47.

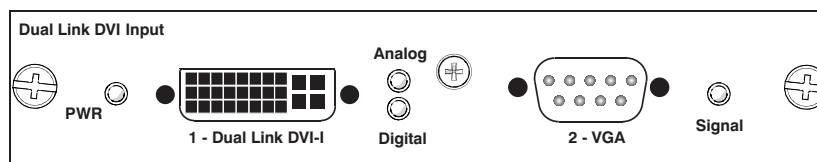

## Four-port input video quadrant mappings

Video quadrant mapping can change depending on the type of cards used for the Four-Port input configurations.

### 3GIC, TDPIC, THIC cards

The following table shows the video quadrant mappings for the 3GIC, TDPIC and THIC Four-Port input configurations:

Four-Port Input Configuration (1)		
Slot 1	1-In	Top left
Slot 1	2-In	Bottom left

Slot 2	1-In	Top right
Slot 2	2-In	Bottom right
Four-Port Input Configuration (2)		
Slot 3	1-In	Top left
Slot 3	2-In	Bottom left
Slot 4	1-In	Top right
Slot 4	2-In	Bottom right

### DDIC card

The following table shows the video quadrant mappings for the DDIC Four-Port input configuration:

Four-Port Input Configuration		
Slot 1	1-Dual Link DVI-I	Top left
Slot 2	1-Dual Link DVI-I	Top right
Slot 3	1-Dual Link DVI-I	Bottom left
Slot 4	1-Dual Link DVI-I	Bottom right

### Connect devices to the 3D sync ports

The 3D Sync Input and Output ports located on the MCPU faceplate provide a convenient method for interfacing the projector to the 3D stereo projection system. The 3D Sync Input should be connected to the 3D video source for synchronization of the left eye/right eye frames. The 3D Sync Output is available for control of an IR Emitter for active glasses or a polarization device for passive glasses.

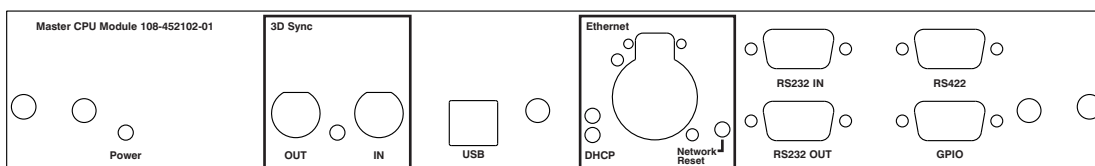

### Connect a computer or server

To communicate with a remote computer, server, or an existing network, use an RJ45 cable to connect the Ethernet hub or switch to the Ethernet port, located on the projector MCPU faceplate. When using the Christie serial protocol over Ethernet, connect to port 3002.

For applications or equipment with serial connectors, use the Christie-proprietary serial protocol to communicate with the RS422 port or the RS232 ports on the MCPU faceplate.

**NOTICE**

The RS232 port located on the MCPU faceplate uses Christie-proprietary protocol and is intended for Christie accessories or automation controllers only. Failure to comply may result in equipment damage.

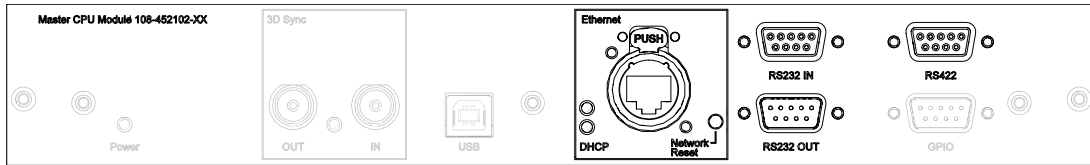



# Adjust the Image



Always follow the laser safety regulations when completing any mechanical adjustments. Turn the laser power down to a safe level before opening the projector. Failure to comply could result in death or serious injury.

For optimum results, follow the procedures in this section in the order that they appear. *Do not complete procedures out of order.* Image adjustment is an iterative process.

## Turn the system on

1. Check the interlock cables are securely attached to the Laser Modules.
2. Check the interlock cable to the projector is securely attached.
3. Check the Ethernet cable between the projector and the Rack Switch is securely attached.
4. Check the Ethernet cable between the Laser Bank Manager and the Rack Switch is securely attached.
5. Turn the Rack Switch on.
6. Turn on the Laser Bank Manager.
7. Turn on the circuit breaker on the projector baseplate under the front lens-side corner.
8. If the emergency-stop button on either the Laser Rack or the projector is activated, release it by turning the button clockwise.
9. Turn the Beam Stop on the projector to **OPEN**.
10. Turn the Laser Rack key switch on.  
The key must be in the switch at all times.
11. Turn on the Rack Switch at the rear of the Laser Rack.
12. Turn on the breakers (one per Laser Module) in the power distribution unit in the front of the Laser Rack.
13. Press **MANUAL RESET** on the side of the Laser Rack or on the back of the projector.

Wait for a few seconds for the interlock to close and the laser emission status lights on the rear of the projector to turn on.

14. Verify the status lights on the back of the projector and the front of the Laser Modules are white.

The projector is armed, but the lasers are off.

## Test the interlocks

Once the projector is running, ensure the safety interlocks are functioning.



Before displaying an image from the projector, test the three interlock devices. Every time the interlock is activated, the Laser Modules turn off. Failure to comply could result in death or serious injury.

## Test the key switch

1. Turn the key switch on the Laser Rack off.
2. Check the status lights on the back of the projector are off.
3. Turn on the key switch.
4. Press **Manual Reset** on the projector.

## Test the Laser Rack emergency stop

1. Press the emergency stop button on the Laser Rack.
2. Check the status lights on the back of the projector are off.
3. To release the E-stop, rotate the knob clockwise.
4. Press **Manual Reset** on the projector.

## Test the projector emergency stop

1. Press the emergency stop button on the projector.
2. Check the status lights on the back of the projector are off.
3. To release the E-stop, rotate the knob clockwise.
4. Press **Manual Reset** on the projector.

## Add the Laser Modules to the system

1. On the Laser Bank Controller, start the Laser Bank Control Application.
2. Under **Available Modules**, click **Add IP**.
3. Enter **192.168.252.1**.

4. Click **Add IP** and enter **192.168.252.50**.
5. Under **Available Modules**, click **Connect All**.

## Disconnect all but one Laser Modules

Initial image adjustments require low power from a single Laser Module.

1. Under **Connected Modules**, select the IP address of a Laser Module you want to disconnect.
2. Click **Disconnect**.
3. Repeat steps 1 to 2 until there is only one Laser Module connected.

## Image adjustments performed with low white light



Make image adjustments with low light levels from a single Laser Module. Failure to comply could result in minor or moderate injury.

The image adjustments described in this section are done with low light from a single Laser Module.

### Orient the screen image

1. To display the a white test pattern, on the Home tab in the Pattern list, select **Flat White**.
2. Tap **Menu > Configuration > Image Orientation**.
3. Select the orientation you want from the list.

### Calibrate the lens motors

1. On the TPC screen, tap **Lens > Calibrate Lens**.

### Adjust the image to fit the screen

1. Center the image on the screen.
  - a. On the TPC, tap the **Lens** tab.
  - b. Tap the left, right, up, and down arrows until the image is centered on the screen.
2. To display the DC2K Framing2 test pattern, on the Home tab in the Pattern list, select **DC2K Framing2**.
3. To adjust the position of the test pattern, repeat step 1.
4. Under **Zoom**, tap the magnifying glasses until the image fits the screen.
5. Under **Focus**, tap the left and right arrows until the test pattern details are in focus.

The words and lines on the test pattern should be distinguishable uniformly across the screen.

## Adjust the offset



- For the best optical performance and minimal keystone error, use offset and not aiming to center the image in off-axis installations.
- Avoid extreme tilts or offsets. Corner vignettes on a white test pattern indicate extreme offset that should be avoided using mechanical alignment.

1. Select a framing test pattern and adjust the horizontal and vertical offset to display a square image on the screen with minimal projector aiming error.

## Adjust the offset with an Intelligent Lens System (ILS)



- For the best optical performance and minimal keystone error, use offset and not aiming to center the image in off-axis installations.
- Avoid extreme tilts or offsets. Corner vignettes on a white test pattern indicate extreme offset that should be avoided using mechanical alignment.

1. Tap **Menu > Advanced Setup > Lens Setup**.
2. Verify the correct lens is selected.
3. Tap **Enable Automatic ILS**.

Modifying the offset now results in overwriting the pre-defined settings.

4. Tap the Test Patterns button and select a framing test pattern.
5. Tap **Menu > Advanced Setup > ILS File Setup**.
6. Tap the arrows in the Offset area.

## Rotate the integrator rod

The integrator rod is aligned by Christie. If there are screen shadows, perform this procedure.

1. Unlock and open the optical access door.
2. Loosen the two screws (3 mm hex) securing the retaining clip to the rear of the integrator using an allen key.  
  
Use caution when removing these screws to avoid damaging the Remote Temperature Sensor Module (RTSM).
3. Rotate the integrator rod to remove the shadow from the corners.
4. To focus the integrator rod, slide it forward and back.
5. Tighten the two retaining clip screws to secure the integrator rod.
6. Close and lock the optical access door.

## Align the fold mirror

Align the fold mirror if a corner or edge of an image is missing.

1. Adjust the two screws located on the bottom front of the projector.
2. To raise or lower the image, adjust the screw closest to the operator side (right-side when facing screen).
3. To move the image left or right, adjust the screw furthest from the operator side.

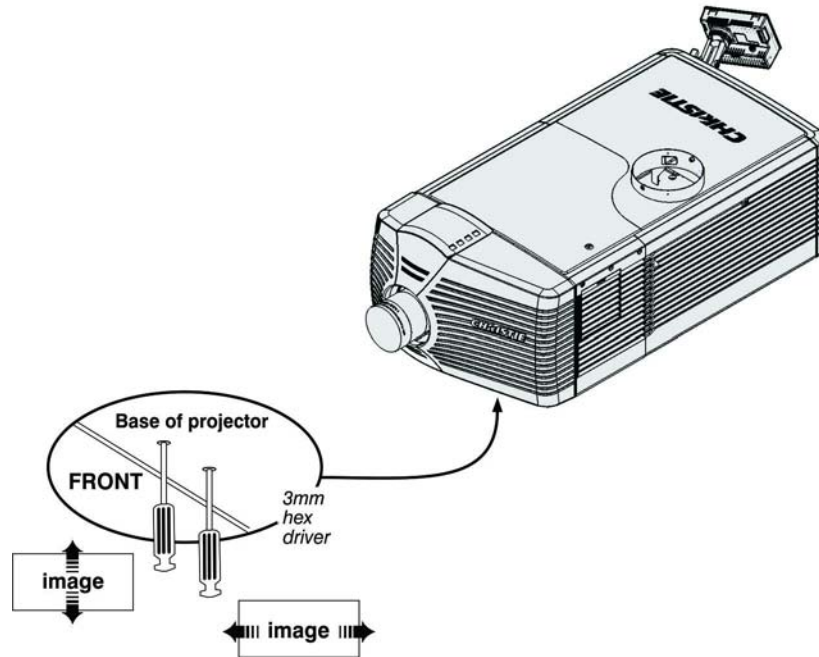

You may have to repeat the integrator and the fold mirror alignments until the corners are focused and the shadows are off the screen.

## Adjust horizontal boresight

### ⚠ WARNING

Failure to comply with the following could result in death or serious injury.

- Do not look into the lens. The extreme brightness can cause permanent eye damage.
- Keep hands, clothing, and all combustible material away from the light path.

### ⚠ CAUTION

Adjust the Boresight with low light levels from a single Laser Module. Failure to comply could result in minor or moderate injury.

Adjust the boresight if the image cannot be focused uniformly across the screen.

1. Loosen the lens mount stabilization screw (D)

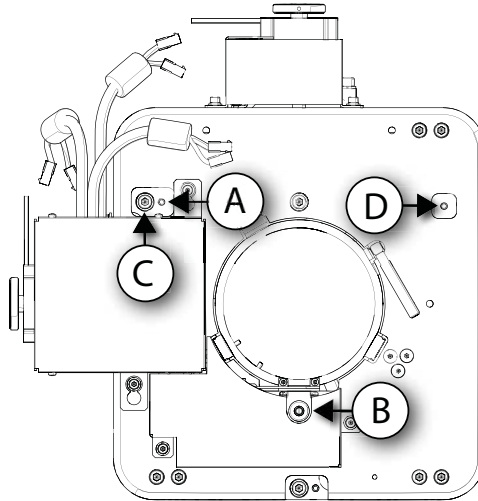

2. Loosen the horizontal lock screw (A).
3. Extend the lens focus (B) completely.
4. Using the focus knob to retract the lens, adjust the **Focus**. Watch the image at the left edge of the screen until it comes into focus.  
If the entire screen is in focus, proceed to step 8.
5. Continue retracting the lens.
  - a. If the right side of the image comes into focus before the lens is completely retracted, adjust the horizontal boresight bolt (C) to balance the left and right edges.
  - b. If the right side of the image fails to focus, adjust the horizontal boresight bolt (C).
6. When both sides appear equally blurry, adjust the offsets to re-center the image.
7. Repeat steps 1 to 6 until both sides of the image are focused.
8. Tighten the lock screw (A) and the lens mount stabilization screw (D) to maintain the adjustments.
9. Check the boresight again.
10. Unless proceeding to adjust vertical boresight, calibrate the lens motors: on the TPC tap **Lens** > **Calibrate Lens**.

## Adjust vertical boresight

1. Focus the image at the top edge of the screen.

2. Loosen the lens mount stabilization screw (D).

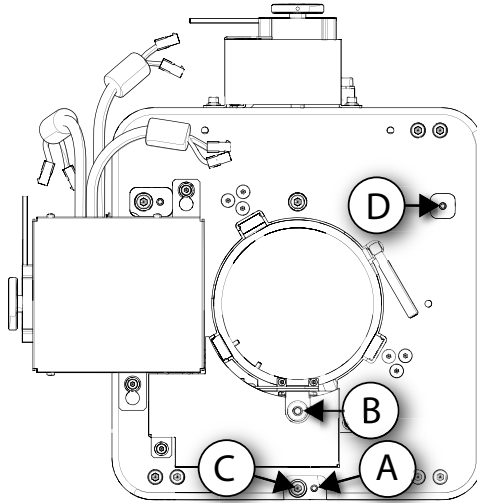

3. Loosen the vertical lock screw (A).
4. Extend the lens focus (B) completely.
5. To retract the lens, adjust the **Focus** knob. Watch the image at the top edge of the screen until it comes into focus.

If the entire screen is in focus, proceed to step 10.

6. Continue retracting the lens.
  - a. If the bottom edge of the image comes into focus before the lens is completely retracted, adjust the vertical boresight bolt (C) to direct or aim the lens mount UP towards the top of the screen to balance the top/bottom edges.
  - b. If the top edge of the image is not in focus, adjust the vertical boresight bolt (C) to direct or aim the lens mount toward the bottom of the screen.
7. When both sides appear equally blurry, adjust the horizontal and/or vertical offset to re-center the image on the screen.
8. Repeat steps 2 to 7 until the top and bottom of the screen are both well-focused.
9. Re-focus the center of the image. The goal is for good focus at the center and on all sides.
10. Tighten the lock screw (A) and the lens mount stabilization screw (D) to maintain the adjustments.
11. Check the boresight again.
12. Calibrate the lens motors: on the TPC tap **Lens > Calibrate Lens**.

## Image adjustments with full light

The image adjustments described in this section are done with all Laser Modules.

## Turn on all Laser Modules

The remaining image adjustments require power on all Laser Modules.

1. In the Laser Bank Control Application under Available Modules, click **Connect All**.
2. Under **System > Power Status**, click **Standby**.  
The Laser Module tabs read WARMUP.
3. When the Laser Module tabs read STANDBY, click **On**.
4. In the System Power group, bring Green to 100 %.

## Adjust horizontal boresight

### ⚠ WARNING

Failure to comply with the following could result in death or serious injury.

- Do not look into the lens. The extreme brightness will cause permanent eye damage.
- Keep hands, clothing, and all combustible material away from the light path.

### ⚠ CAUTION

Adjust the Boresight with low light levels from a single Laser Module. Failure to comply could result in minor or moderate injury.

Adjust the boresight if the image cannot be focused uniformly across the screen.

1. Loosen the horizontal lock screw (A).

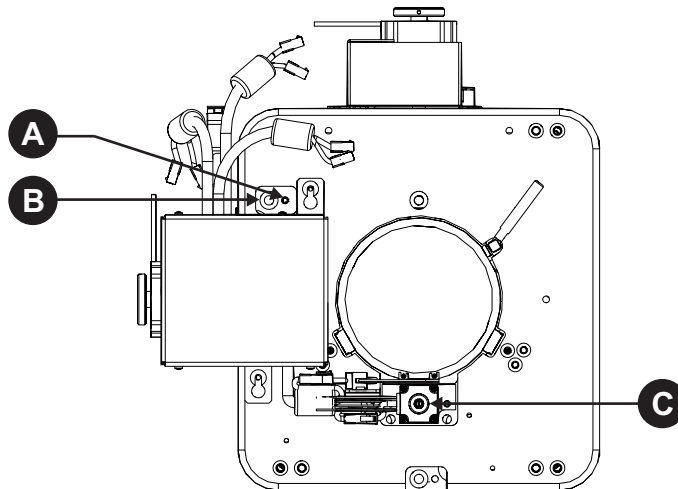

2. Extend the lens focus completely.

Retract the lens with the focus knob (C) to adjust the **Focus**. Watch the image at the left edge of the screen until it comes into focus.

3. If the entire screen is in focus, proceed to step 8.
4. Continue retracting the lens.
  - a. If the right side of the image comes into focus before the lens is completely retracted, adjust the horizontal boresight bolt (B) to balance the left and right edges.



- b. If the right side of the image fails to focus, adjust the horizontal boresight bolt (B).
5. When both sides appear equally blurry, adjust the focus (C) to re-center the image.
6. Repeat steps 1 to 5 until both sides of the image are focused.
7. Tighten the horizontal lock screw (A) to maintain the adjustments.
8. Check the boresight again.
9. If you need to adjust the vertical boresight, skip to the next section. See [Adjust vertical boresight](#) on page 57.

## Adjust vertical boresight

Perform this procedure if there is no ILS. If there is an ILS, see [Adjust vertical boresight with an ILS](#) on page 58.

1. Focus the image at the top edge of the screen.
2. Loosen the vertical lock screw (A).

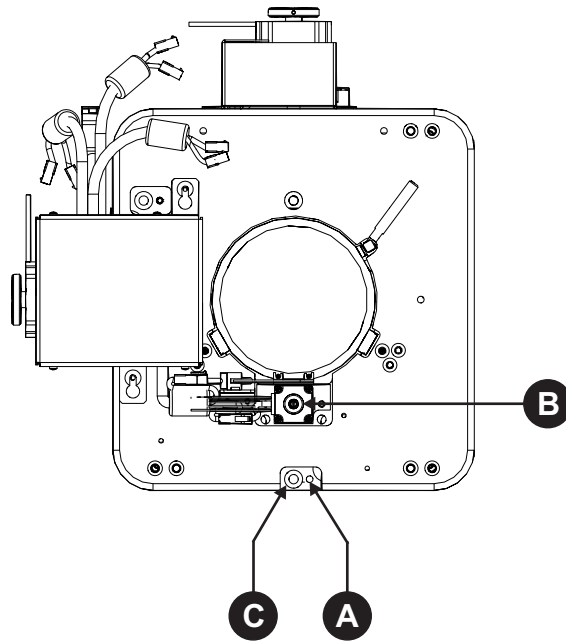

3. Extend the lens focus (B) completely.
4. To retract the lens, adjust the **Focus** knob (B). Watch the image at the top edge of the screen until it comes into focus.  
If the entire screen is in focus, proceed to step 8.
5. Continue retracting the lens.
  - a. If the bottom edge of the image comes into focus before the lens is completely retracted, adjust the vertical boresight bolt (C) to direct or aim the lens mount UP towards the top of the screen to balance the top/bottom edges.

- b. If the top edge of the image is not in focus, adjust the vertical boresight bolt (C) to direct or aim the lens mount toward the bottom of the screen.
6. When both sides appear equally blurry, adjust the horizontal and/or vertical offset to re-center the image on the screen.
7. Repeat steps 2 to 6 until the top and bottom of the screen are both well-focused.
8. Re-focus the center of the image. The goal is for good focus at the center and on all sides.
9. Tighten the vertical lock screw (A) to maintain the adjustments.
10. Check the boresight again.

## Adjust vertical boresight with an ILS

Perform this procedure if there is an ILS. If there is no ILS, see [Adjust vertical boresight](#) on page 57.

1. Focus the image at the top edge of the screen.
2. Loosen the vertical lock screw (A).

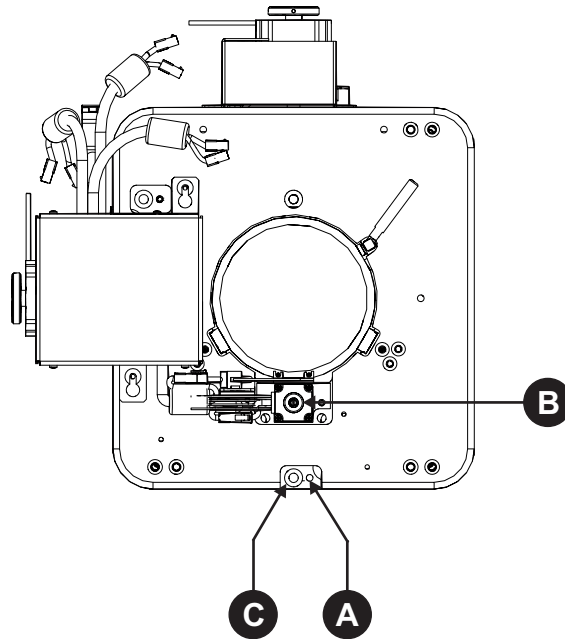

3. Extend the lens focus (B) completely.
4. To retract the lens, adjust the **Focus** using the counter-clockwise button on the ILS Adjust window. Watch the image at the top edge of the screen until it comes into focus. If the image appears well-focused on the top edge but not on the bottom, determine if the bottom edge focuses in front of or behind the screen.  
  
If the entire screen is in focus, proceed to step 8.
5. Continue retracting the lens.

- a. If the bottom edge of the image comes into focus before the lens is completely retracted, adjust the vertical boresight bolt (C) to direct or aim the lens mount UP towards the top of the screen to balance the top/bottom edges.
  - b. If the top edge of the image is not in focus, adjust the vertical boresight bolt (C) to direct or aim the lens mount toward the bottom of the screen.
6. When both sides appear equally blurry, tap menu > Advanced Setup > ILS File Setup and tap the directional arrows in the Offset area to center the image on the screen.
  7. Repeat steps 2 to 6 until the top and bottom of the screen are both well-focused.
  8. Re-focus the center of the image. The goal is for good focus at the center and on all sides.
  9. Tighten the vertical lock screw (A) to maintain the adjustments.
  10. Check the boresight again.

## Calibrate lens motors

1. On the TPC, tap **Lens** > **Calibrate Lens**.

## Adjust DMD convergence

### CAUTION

Failure to comply with the following could result in minor or moderate injury.

- Always wear an electrostatic discharge (ESD) strap and use insulated tools when replacing the light engine or any other circuit board; however, Christie does not recommend wearing a strap while converging a live unit, but to instead ensure frequent contact with the bare metal of the projector to prevent static buildup.
- Do not touch the heat sink in the Light Engine compartment when converging a projector as it can cause burns.

### NOTICE

Do not run the projector while performing convergence with the Light Engine Fan Pack removed. This causes overheating of the Satellite Formatter Board FPGAs. Failure to comply may result in equipment damage.



- All procedures must be followed as described and performed by Christie authorized, trained personnel.
- Safety glasses are not required for convergence as exposures greater than Class 1 are not possible.
- These instructions are intended to be a supplement descriptive guideline for information on convergence. Personal tool preference, mechanical experience, and individual techniques are all variables that make this document a subjective tool for use only by experienced professional technicians.

The projector uses three separate digital micromirror device (DMD) panels to produce three separate red, green, and blue image components. To ensure the most accurate color representation

across the whole image, adjust the convergence to perfectly align the three panels so that all pixels line up. Read this entire section before adjusting convergence.

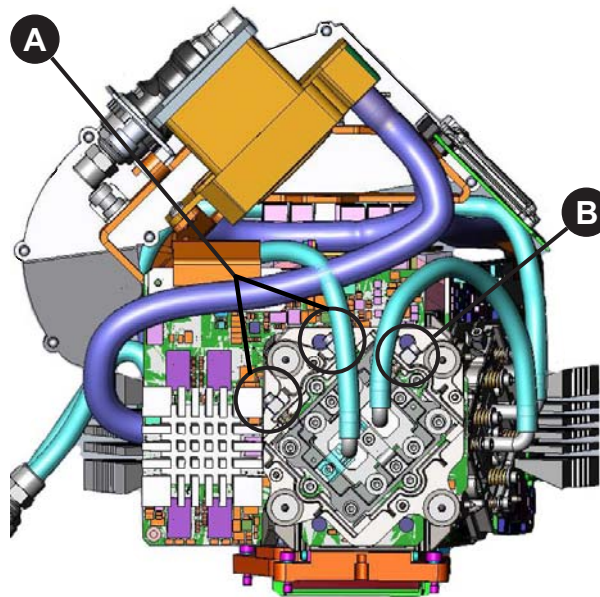

<b>A</b>	Screws 1 and 2: Vertical and Twist Adjustment
<b>B</b>	Screw 3: Horizontal Adjustment

### Before convergence

- Make sure image zoom and centering is complete.
- Make sure boresight procedures are completed.
- Allow the projector to warm up for 15 minutes to reach nominal operating temperature.
- During convergence, the lid and/or filter side of the projector is open, causing decreased prism cooling performance and possible shifts in convergence or DMD focus. The prism temperature must be monitored during the adjustment and kept within a few degrees of the nominal temperature achieved above by lowering the laser power or periodically replacing the cover for a cool-down.
- If the procedure takes longer than an hour, watch for over-temperature alerts. Cool-down periods with the douser closed and cover on may be required.
- Typically the blue image component can be used as the fixed reference, so no adjustment is required. However, if you need to adjust the blue image component it is easy to adjust, but the side panel must be removed. The recommended normal convergence adjustments are from green to blue and red to green.
- Christie recommends that the vertical and rotation adjustment be done first, as they work dependently together, and the horizontal adjustment done last.
- Use extreme caution to not damage any electronic components.

- Do not force the adjustment, the board should move easily with gentle pressure.

### Evaluate convergence

1. Display either the **Alignment Pattern** or the **Framing Pattern**.

The framing pattern may not be installed on the projector in some cases. Keep a copy of this pattern on your computer and load it to the projector you are working on if not present.

2. Zoom and focus the image to see the entire outer edge of the test pattern frame.

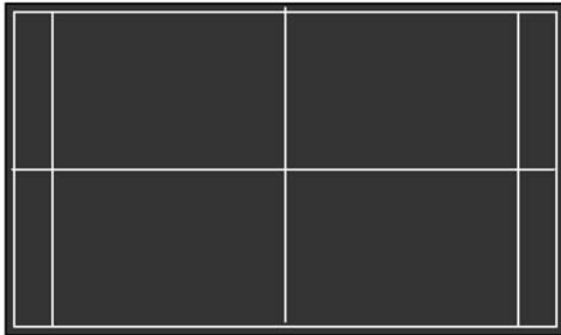

Alignment Pattern

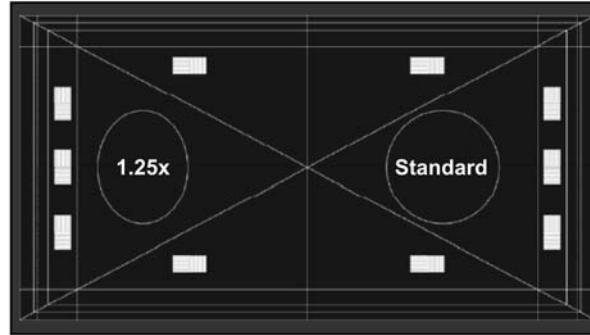

Framing Pattern

3. Using the horizontal and vertical white lines, you can judge the convergence issues. Look at one color at a time and remember that you can see a possible seven colors to lead you to a valid conclusion. The stripe pattern boxes along the outer frames can be helpful as well.

Magenta = Blue + Red / Yellow = Green + Red / Cyan = Green + Blue / White = Red + Green + Blue



4. Look for *twist* using the center vertical and horizontal lines—scan from one side of the screen to the other, observing any change in vertical position of the color in question relative to the point where you started.

### Adjust formatter convergence



Remove all jewelry (rings, watches, necklaces, bracelets and so on) before adjusting convergence.



Do not apply excessive force on the adjustment screws. This might cause the convergence adjustment to become misaligned once you remove the adjustment tool.

The red and green formatters are identical in physical layout and adjuster function. The blue formatter board is slightly different in physical layout, but the adjustment functions are the same. The twist and vertical adjustments interact with each other on the horizontal axis.

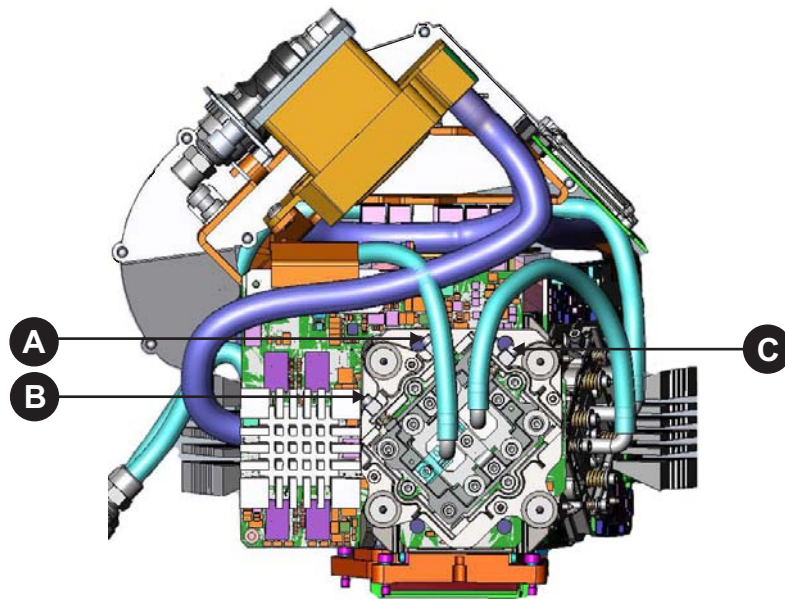

Screen / Screw	A	B	C
			N/A
			N/A
			N/A
			N/A
	N/A	N/A	
	N/A	N/A	

The physical layout of the Formatter boards dictates the behavior of the twist and vertical adjustments:

- The adjustment is like a “Twist with the left-side of the screen as a sliding hinge point to allow vertical travel”.
- The vertical adjustment screw and twist adjustment screw interact with each other such that if one is turned in the opposite direction of the other, the twist is affected.
- If both screws are turned equal amounts in the same direction, the image moves vertically.
- Remove the light engine air filter and fan pack to access the blue convergence adjustment screws.

Cooling is affected by removing the filter and fan pack assembly.

You do not always have to turn the screws simultaneously; however, adjusting one at a time requires equal or equal and opposite turn on the other to prevent binding and achieve the required adjustment. It is recommended to locate the shorter blade 2.5 mm driver on adjusting screw #2 (especially on the red), and use the longer blade 2.5 mm driver for screw #1 and horizontal (screw #3).

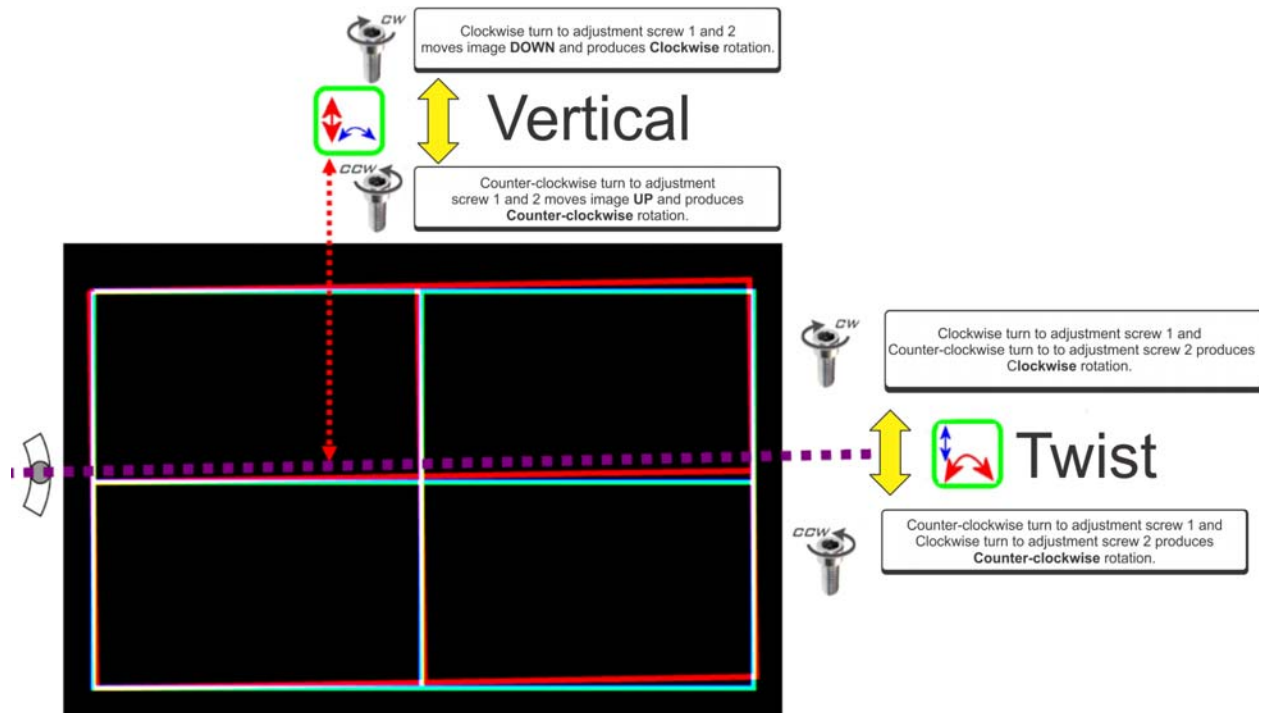

- The horizontal adjustment screw is independent of the twist and vertical adjustments.

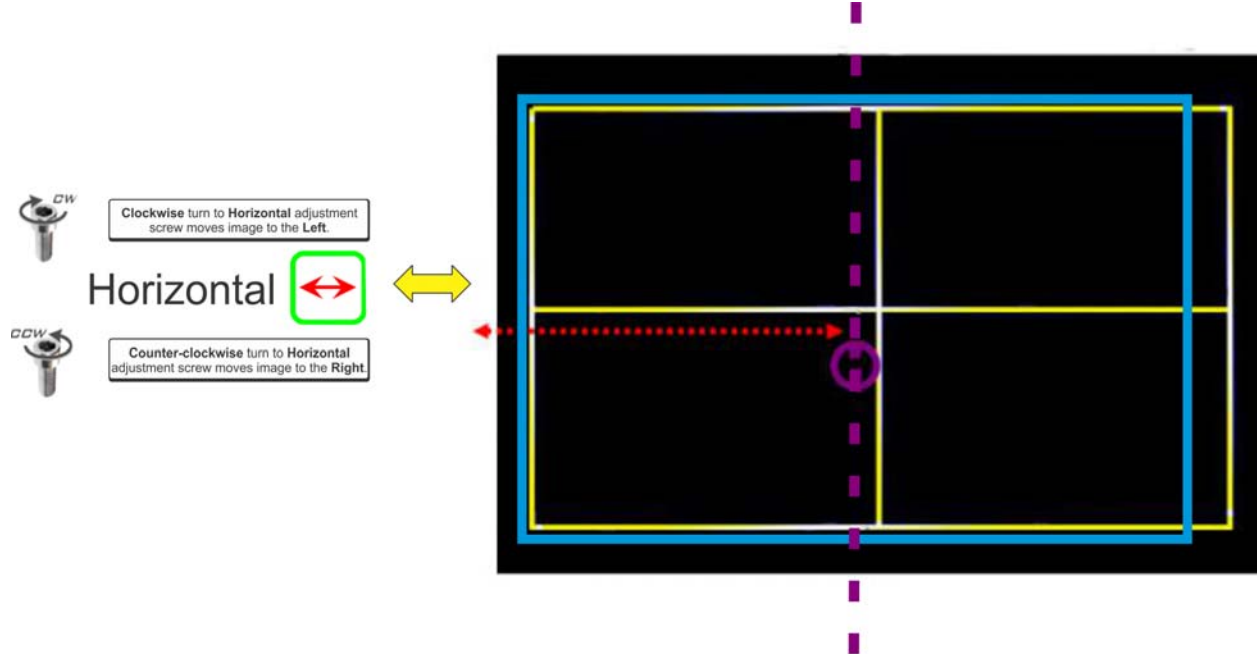

- Christie recommends that you locate the twist adjustment screw with the 2.5mm Allen driver and leave it in place, resting against the lens mount/formatter board.
- Use a second driver to adjust the horizontal/twist adjustment screw or the vertical adjustment screw.

### Final convergence assessment

- On the prisms, the red image is slightly larger than the blue and green. The larger size is caused by the natural properties of Red light due to a *slow* wavelength compared to blue and green. The angle that light is traveling is affected by every medium it travels through, and in this case several pieces of glass are between red and the screen—the red image is affected more so as it ends up slightly larger.
  - This means that the best possible convergence would be the center area should be perfectly aligned showing solid white pixels, as shown in the simplified diagram.
  - The Red must be evenly 1/4 to 1/2 a pixel out all the way around the outer area, showing cyan (green + blue) towards the center of the screen.



- c. Green and blue must always be perfectly aligned to each-other (to within 1/4 pixel total in one or a combination of directions.)

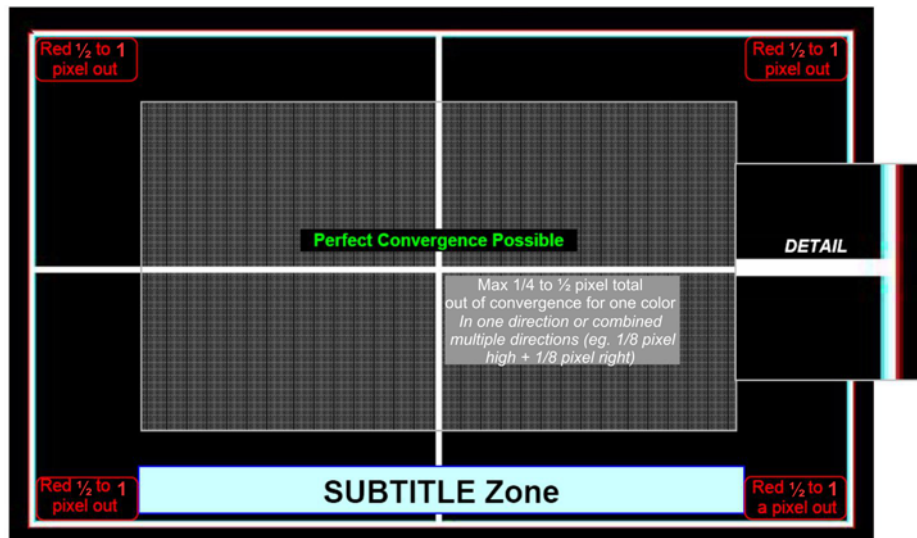

2. In certain circumstances, there may be further tolerance deficiencies in the prism assembly in combination with the projection lens that causes the normal Red over-sizing to become slightly non-uniform.
- In practice, this extra increase in size has generally appeared on the lower-right of the image, causing an apparent clockwise twist in the lower-right corner only—the upper left, right and lower-left all look fine.
  - To “Split the difference” push the rest of the image slightly twisted counter-clockwise to minimize the effect on the bottom of the screen, keep the subtitle zone as converged as possible.
  - If the problem appears to be more than an extra 1/2 of a pixel out of uniformity, a new lens/prism assembly may be the only solution.

## Obtain the white point and brightness

Create a white point laser setting file for 3D and 2D channels. You may also need to create one for scope and flat features.

- In the Laser Bank Control Application under Screens, click **System**.
- Under Color Levels, move the System Green control (CTL) slider to 100 %.
- Wait approximately 30 seconds for the green lasers to respond.  
Every time you adjust the green lasers, wait for the lasers to move to the new value.
- Using a spectroradiometer, such as Photo Research PR-655 SpectraScan® measure the brightness and color of the screen.
- Move the System Red and System blue CTL sliders up or down to bring the measured values closer to the target white point values:

$x = 0.312, y = 0.329$

For more precise adjustments, click the cap on the slider and press the up and down arrow keys.

6. Repeat steps 4 to 5 until the measured values are approximately the same as the target white point.

## Save the laser settings

1. On the System tab under Configuration Management, click **Save**.
2. Type a name for the settings file and press Enter.

## Add the projector to a network

1. On the TPC, tap **Menu > Communications > Ethernet Settings > Modify IP Settings**.
2. To obtain the IP address automatically, tap **Automatic** then **Ok**.
3. To specify the settings, tap Manual, type the IP Address, Subnet Mask, and Gateway (optional), then tap **Ok**.

## Turn system off

1. On the TPC on the projector, tap and hold **Power**.

## Turn system off in an emergency

1. Press the E-Stop button either on the back of the projector (see [Projector safety features](#) on page 23) or on the operator side of the Laser Rack (see [LM Rack safety features](#) on page 22) to shut down the Laser Modules.

The Laser Modules turn off.

# Troubleshooting

The section provides information about Laser Module status on the Laser Bank Control Application.

## Check the Laser Module status

1. Open the Christie Laser Bank Manager application.
2. Review the quick status panels (A).

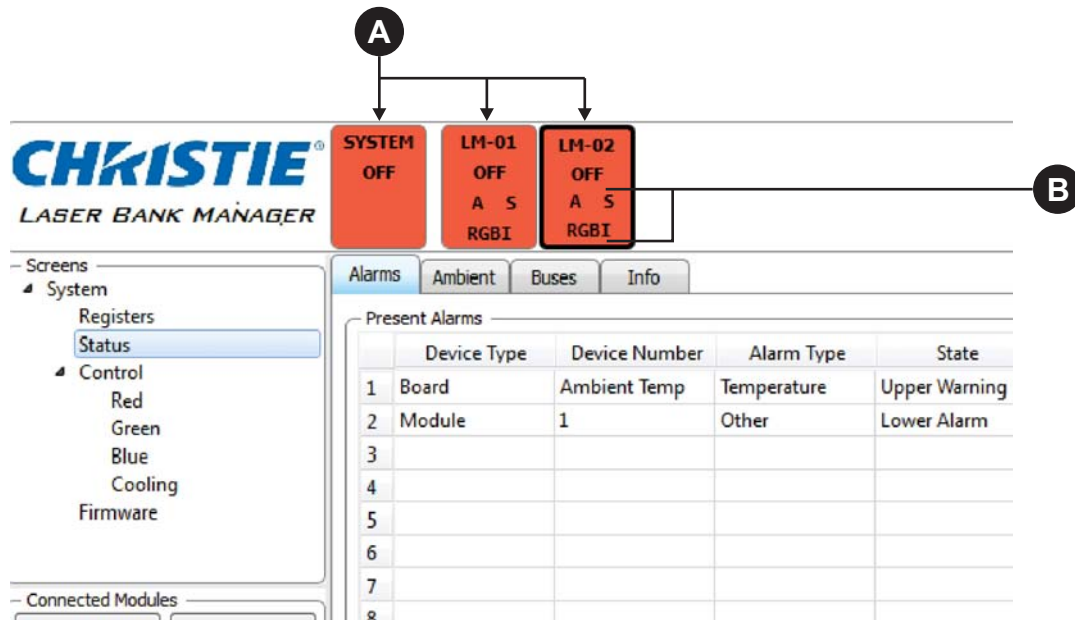

During normal operation, the quick status panels have a green background. A yellow background indicates a warning, and a red background indicates an alarm condition.

Do not operate a Laser Module if the humidity sensor is not working. Operating with a failed humidity sensor can reduce the longevity of the laser and void the warranty. Failure to comply may result in equipment damage.

3. Check the alarm codes (B).

Code	Description
V	Bus voltages

Code	Description
A	Ambient temperature
F	Fans
C	Chiller
S	File System (SD card)
E	Red enclosure
R	Red laser
G	Green laser
B	Blue laser
I	Interlock
P	Power-up

4. Click the corresponding quick status panel to open a status pane for a specific Laser Module.
5. Click the **Alarms** tab to view the alarm type and status.
6. To view the current ambient temperature and warning and alarm thresholds, click the **Ambient** tab.
7. To view bus voltage levels, click the **Buses** tab.
8. To view Laser Module build, software, and use data, click the **Info** tab.

## Missing focus/zoom warning

If you calibrate the lens with a fixed lens installed, a warning appears about the missing focus/zoom. The calibration itself is correct. The error disappears the next time the projector is turned on.

# Projector Specifications

This section provides detailed specifications for the projector head.

## Power requirements

Item	Description
Voltage	100 -240 VAC
Maximum Current	10 A
Line Frequency	50 - 60 Hz
Inrush Current	45 A maximum

# Signal connectivity

Input Configuration	Input Format	Frame Rate (Hz)	Interface	Cards	Cables	RGB/4:4:4 8-bit	RGB/4:4:4 10-bit	RGB/4:4:4 12-bit	4:2:2 8-bit	4:2:2 10-bit	4:2:2 12-bit
Four-Port	4K, QHD	24, 25, 30, 48, 50, 60	DisplayPort	2x TDPIC	4	X	X		X	X	X
Four-Port	4K, QHD	24, 25, 30, 48, 50, 60	HDMI	2x THIC	4	X	X	X	X	X	X
Four-Port	4K, QHD	24, 25, 30, 48, 50, 60	3G-SDI	2x3GIC	4					X	
Four-Port	4K, QHD	24, 25, 30, 48, 50, 60	DVI (Single Link)	4x DDIC	4	X					
One-Port	2K, HD	24, 25, 30, 48, 50, 60	DisplayPort	1x TDPIC	1	X	X		X	X	X
One-Port	2K, HD	24, 25, 30, 48, 50, 60	HDMI	1x THIC	1	X	X	X	X	X	X
One-Port	2K, HD	24, 25, 30	3G-SDI	1x 3GIC	1	X	X	X	X	X	X
One-Port	2K, HD	48, 50, 60	3G-SDI	1x 3GIC	1					X	
One-Port	2K, HD	24, 25, 30, 48, 50, 60	DVI (Single Link)	1x DDIC	1	X					

# Signal connectivity

2D/3D	Input Configuration	3D Type	Input Format	Frame Rate (Hz)	Interface	Cards	Cables	RGB/4:4:4 8-bit	RGB/4:4:4 10-bit	RGB/4:4:4 12-bit	4:2:2 8-bit	4:2:2 10-bit	4:2:2 12-bit
3D	Four-Port	Direct	4K, QHD	120	DisplayPort	4x TDPIC	4	X	X				
3D	Four-Port	Direct	4K, QHD	120	DVI (Dual Link)	4x DDIC	4	X					
3D	Four-Port	Dual-Input	4K, QHD	60	DisplayPort	4x TDPIC	8	X	X		X	X	X
3D	Four-Port	Dual-Input	4K, QHD	60	HDMI	4x THIC	8	X	X	X	X	X	X
3D	Four-Port	Dual-Input	4K, QHD	60	3G-SDI	4x 3GIC	8					X	
3D	Four-Port	Direct	4K, QHD	60	DisplayPort	2x TDPIC	4	X	X		X	X	X
3D	Four-Port	Direct	4K, QHD	60	HDMI	2x THIC	4	X	X	X	X	X	X
3D	Four-Port	Direct	4K, QHD	60	3G-SDI	2x 3GIC	4					X	
3D	Four-Port	Direct	4K, QHD	60	DVI (Single Link)	4x DDIC	4	X					
3D	One-Port	Dual-Input	2K, HD	60	DisplayPort	1x TDPIC	2	X	X		X	X	X
3D	One-Port	Dual-Input	2K, HD	60	HDMI	1x THIC	2	X	X	X	X	X	X
3D	One-Port	Dual-Input	2K, HD	60	3G-SDI	1x 3GIC	2					X	
3D	One-Port	Dual-Input	2K, HD	60	DVI (Single Link)	2x DDIC	2	X					
3D	One-Port	Direct	2K, HD	120	DisplayPort	1x TDPIC	1	X	X				
3D	One-Port	Direct	2K, HD	120	DVI (Dual Link)	1x DDIC	1	X					
2D	Four-Port		4K, QHD	120	DisplayPort	4x TDPIC	4	X	X				
2D	Four-Port		4K, QHD	120	DVI (Dual Link)	4x DDIC	4	X					
2D	One-Port		2K, HD	120	DisplayPort	1x TDPIC	1	X	X				
2D	One-Port		2K, HD	120	DVI (Dual Link)	1x DDIC	1	X					

- 4K = 4096 x 2160
- QHD = 3840 x 2160
- 2K = 2048 x 1080
- HD = 1920 x 1080

## Physical specifications

Item	Description
Size (L x W x H) (without front shroud)	(without lens mount, stack, and feet) 1097 mm (43.2 inches) x 644 mm (25.4 inches) x 432 mm (17.0 inches)
	(includes lens mount, stack, and feet) 1211 mm (47.7 inches) x 644 mm (25.4 inches) x 480 mm (19.0 inches)
	Shipping (includes skid) 1448 mm (57inches) x 914 mm (36 inches) x 711 mm (28 inches)
Size (L x W x H) (with front shroud)	(includes front shroud, stack, and feet) 1330 mm (52.4inches) x 644 mm (25.4 inches) x 480 mm (19.0 inches)
	Front shroud is shipped separately
Weight (without front shroud)	102 kg (224 pounds)
	Shipping (includes packaging) 133 kg (294 pounds)
Weight (with front shroud)	104 kg (230 pounds)
	Shipping (includes packaging) 136 kg (300 pounds)

## Operating position

This diagram shows how the projection can be positioned .

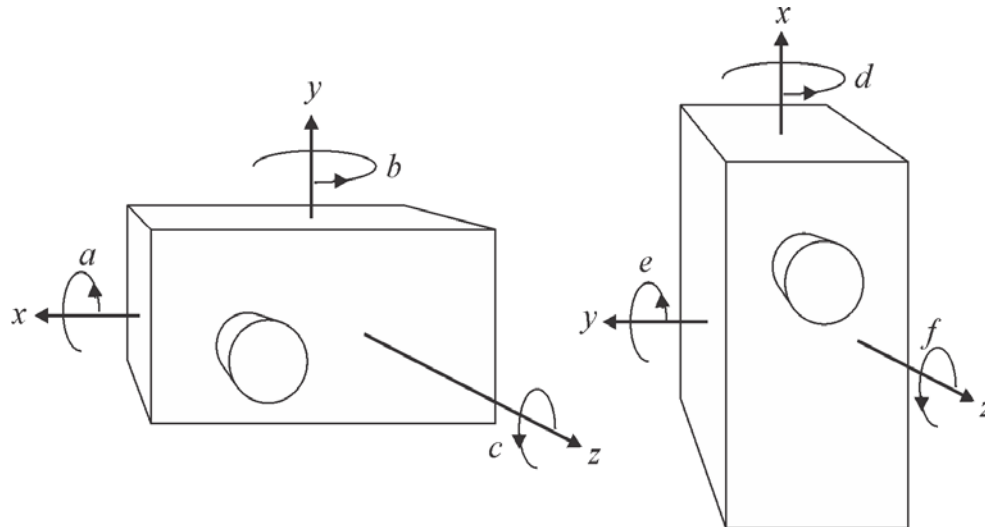

Angle	Range
a	-105 degrees to 105 degrees



Angle	Range
b	360 degrees
c	15 degrees to -105 degrees
d	360 degrees
e	-105 degrees to 105 degrees
f	-15 degrees to 105 degrees

## Operating environment

Item	Description
Temperature	10 °C to 25 °C (50 °F to 77 °F)
Humidity (non-condensing)	20% to 80%

## Non-operating environment

Item	Description
Temperature	-20 °C to 60 °C (-4 °F to 140 °F)
Humidity (non-condensing)	0% to 95%

## Projection lens compatibility

Item	Description/Part Number
High Brightness Zoom Lenses (HB)	<ul style="list-style-type: none"> <li>• 25-1.45:1 (2K) / 1.13-1.31:1 (4K) (129-104106-xx)</li> <li>• 1.45-1.8:1 (2K) / 1.31-1.63:1 (4K) (129-105107-xx)</li> <li>• 1.8-2.4:1 (2K) / 1.63-2.17:1 (4K) (129-106108-xx)</li> <li>• 2.2-3.0:1 (2K) / 1.98-2.71:1 (4K) (129-107109-xx)</li> <li>• 4.3-6.0:1 (2K) / 3.89-5.43:1 (4K) (129-109101-xx)</li> <li>• 5.5-8.5:1 (2K) / 4.98-7.69:1 (4K) (129-110103-xx)</li> <li>• 3.0-4.3:1 (2K) / 2.71-3.89:1 (4K) (129-108100-xx)</li> </ul>
High Brightness Fixed Zoom Lenses (HB)	<ul style="list-style-type: none"> <li>• 0.8:1 (2K)/0.73:1 (4K) (113-104106-xx) [compromised image quality due to vignetting in corners]</li> <li>• 1:1 (2K)/0.9:1 (4K) (38-809071-xx)</li> <li>• 1:1 (2K)/0.9:1 (4K) matched pair (108-490104-01)</li> </ul>

## Accessories

### Standard

- Touch panel controller with interface cable
- Installation and User Guides
- Interconnect diagram
- Front shroud
- Motors and zoom kit for motorized lens mount
- Lock down screws for lens mount

### Optional

Item	Description/Part Number
Rack Stand	108-282101-xx
Bracket Foot Lock used with optional Rack Stand	116-100101-xx
TPC Remote Cable (30m)	003-111169-xx

### Third-party accessories

- 3D Equipment

### Replacement air filters

Item	Description/Part Number
LAD Filter	03-001982-5XP
Intake LE Filter	003-001184-XX
IOS Air Filter	003-003082-XX
Radiator Filter Washable	003-005009-XX

# Laser Module Specifications

This section provides detailed specifications for Christie Laser Modules. Due to continuing research, specifications are subject to change without notice.

## Power requirements.

Item	Description
Voltage	46 -53 VDC
Maximum Current	22 A

## Physical specifications

Item	Description
Size (L x W x H)	3800 mm (31.5 inches) x 443 mm (17.5 inches) x 130 mm (5.25 inches)
	Shipping (includes packaging) 953 mm (37.5 inches) x 851 mm (33.5 inches) x 286 mm (11.25 inches)
Weight	32 kg (70 pounds)
	Shipping (includes packaging) 46 kg (100 pounds)
Operating Position	Tilt of projection axis from horizontal ± 30 degrees maximum

## Operating environment

Item	Description
Temperature	10 °C to 25 °C (50 °F to 77 °F)
Humidity (non-condensing)	20% to 80%

## Non-operating environment

Item	Description
Temperature	-25 °C to 65 °C (-13 °F to 149 °F)
Humidity (non-condensing)	0% to 95%

## Accessories

### Included

- Ethernet cable
- Interlock cables

### Additional

- LM Rack (Full) P/N 146-110103-XX
- LM Rack (Half) P/N 146-104106-XX
- LM Rack (Full) Plenum P/N 146-109101-XX
- DC Power Harness
- Fiber Bundle
- Modular DC Power Supply

### Optional

- Air Filters
- Replacement Fan Pack

# LM Rack Specifications

This section provides detailed specifications for the LM Rack (Full) and LM Rack (Half).

## Power requirements

One to four single phase circuits power the LM Rack (Full).

One to three single phase circuits power the LM Rack (Half).

Item	Description
Voltage	200 - 240 VAC
Maximum Current	24 A
Line Frequency	50 - 60 Hz

Two single phase circuits for the Rack Switch and the Laser Bank Manager.

Item	Description
Voltage	100 - 240 VAC
Maximum Current	15 A
Line Frequency	50 - 60 Hz

# Physical specifications

## LM Rack (Full)

Item	Description
Length	with front plenum removed 1081.6 mm (42.58 inches)
	with front plenum installed 1375.6 mm (54.16 inches)
Width	without side duct installed 644 mm (25.83 inches)
	with side duct installed 744.6 mm (29.31 inches)
Height	without top duct installed 2196.6 mm (86.48 inches)
	with top duct installed 2296.6 mm (90.42 inches)
	with fiber optic bundle routed through top 2546.6 mm (100.26 inches)
Weight	with front plenum installed 299.8 kg (661 pounds)
	with front plenum removed 263.0 kg (580 pounds)
	with front plenum and rear door removed 257.1 kg (547 pounds)



The optional earthquake kit adds 10 mm (0.39 inches) to the height.

## LM Rack (Half)

Item	Description
Length	1081.6 mm (42.58 inches)
Width	without side duct installed 644 mm (25.83 inches)
	with side duct installed 744.6 mm (29.31 inches)

Item	Description
Height	without top duct installed 1529.8 mm (60.23 inches)
	with top duct installed 1629.8 mm (64.17 inches)
	with fiber optic bundle routed through top 1879.8 mm (74.01 inches)
Weight	204.1 kg (450 pounds)
	with rear door removed 193.7 kg (427 pounds)



The optional earthquake kit adds 10 mm (0.39 inches) to the height.

## Operating environment

Item	Description
Temperature	10 °C to 25 °C (50 °F to 77 °F)
Humidity (non-condensing)	20% to 80%

## Non-operating environment

Item	Description
Temperature	-25 °C to 65 °C (-13 °F to 149 °F)
Humidity (non-condensing)	0% to 95%

# Regulatory

This product conforms to the following regulations related to product safety, environmental requirements and electromagnetic compatibility (EMC). Due to continuing research, specifications are subject to change without notice.

## Safety

- CAN/CSA C22.2 No. 60950-1
- UL 60950-1
- IEC 60950-1
- EN60950

## Laser safety

- IEC 60825-1 (2007)
- FDA CDRH CFR 1040.10
- FDA CDRH CFR 1040.11

## Electro-magnetic compatibility

Item	Description
Emissions	<ul style="list-style-type: none"><li>• FCC CFR47, Part 15, Subpart B, Class A - Unintentional Radiators</li><li>• CAN ICES-3 (A) / NMB-3 (A)</li><li>• CISPR 22/EN 55022 Class A - Information Technology Equipment</li></ul>
Immunity	CISPR 24/EN55024 EMC Requirements - Information Technology Equipment

## Environmental

- EU Directive (2011/65/EU) on the restriction of the uses of certain hazardous substances (RoHS) in electrical and electronic equipment and the applicable official amendment(s).
- EU Regulation (EC) No. 1907/2006 on the registration, evaluation, authorization and restriction of chemicals (REACH) and the applicable official amendment(s).



- EU Directive (2012/19/EU) on waste and electrical and electronic equipment (WEEE) and the applicable official amendment(s).
- China Ministry of Information Industry Order No.39 (02/2006) on the control of pollution caused by electronic information products, hazardous substances concentration limits (SJ/T11363-2006), and the applicable product marking requirements (SJ/T11364-2006)

## Certification

The product is designed to comply with the rules and regulations required for the product to be sold in various regional markets, including USA/Canada, EU, Australia/New Zealand, Kuwait, China, Korea, Japan, Mexico, Ukraine, Russia, India, South Africa, and Saudi Arabia.

# Installation Checklist

Use this checklist to ensure the Christie Laser Projection System installation meets local, municipal, and federal requirements.

Theater Information		
Name:	Address:	
Theater Number:	Phone:	
Technician responsible for classifying product Name:                                  Phone:	Date of Certification:	
Projection System Information		
Manufacturer:	Date of Manufacture:	
Model:	Laser Hazard Classification:	
Serial Number:		
Installer Information		
Company:	Address: Phone:	
Name of representative responsible for safety and compliance:	Title: Phone:	
Other		
List of State, Local and other agencies notified about Class 3B or 4 Digital Cinema Projector Installation		
TRAINING /DOCUMENTATION PROVIDED TO THEATER OPERATOR		
	Yes	No
Training on safe operation and maintenance of laser projection system		
FDA/CDRH installation requirements (modifications must be approved)		
User Manual provided with the laser projection system		
PROJECTOR AND PROJECTION ROOM INSPECTION		
	Yes	No
Laser warning and restricted access signs posted		
Projector securely mounted		
Housing is assembled properly		
Shutter, E-stop, key control, and emission status indicators function correctly		
Laser warning labels are affixed to the projector (including aperture locations)		

THEATER CLEARANCE DISTANCES CONFIRMED	Yes	No
Nominal Ocular Hazard Distance (NOHD) is confirmed to be ____ meters from the projector.		
Describe how the NOHD was confirmed:		
(Note: If measurements are taken, attach the detector and meter model, serial number, and calibration date)		
Beam is 2.5 meters above floor where the audience is permitted to stand and/or 1.0 meters below or lateral		
No objects (except projection window) intercept the beam path within the NOHD		

**Installer's Signature:** \_\_\_\_\_ **Date:** \_\_\_\_\_

## Corporate offices

---

Christie Digital Systems USA, Inc.  
Cypress  
ph: 714 236 8610

Christie Digital Systems Canada Inc.  
Kitchener  
ph: 519 744 8005

## Worldwide offices

---

Australia  
ph: +61 (0) 7 3624 4888

Brazil  
ph: +55 (11) 2548 4753

China (Beijing)  
ph: +86 10 6561 0240

China (Shanghai)  
ph: +86 21 6278 7708

France  
ph: +33 (0) 1 41 21 44 04

Germany  
ph: +49 2161 664540

India  
ph: +91 (080) 6708 9999

Japan (Tokyo)  
ph: 81 3 3599 7481

Korea (Seoul)  
ph: +82 2 702 1601

Mexico  
ph: +52 55 4744 1790

Republic of South Africa  
ph: +27 (0)11 510 0094

Russian Federation  
and Eastern Europe  
ph: +36 (0) 1 47 48 100

Singapore  
ph: +65 6877 8737

Spain  
ph: +34 91 633 9990

United Arab Emirates  
ph: +971 4 3206688

United Kingdom  
ph: +44 (0) 118 977 8000

United States (Arizona)  
ph: 602 943 5700

United States (New York)  
ph: 646 779 2014

## Independant sales consultant offices

Italy  
ph: +39 (0) 2 9902 1161



For the most current technical documentation, visit [www.christiedigital.com](http://www.christiedigital.com).

