

D4K3560



Setup Guide

020-101161-05

NOTICES

COPYRIGHT AND TRADEMARKS

Copyright ©2015 Christie Digital Systems USA Inc. All rights reserved.

All brand names and product names are trademarks, registered trademarks or trade names of their respective holders.

GENERAL

Every effort has been made to ensure accuracy, however in some cases changes in the products or availability could occur which may not be reflected in this document. Christie reserves the right to make changes to specifications at any time without notice. Performance specifications are typical, but may vary depending on conditions beyond Christie's control such as maintenance of the product in proper working conditions. Performance specifications are based on information available at the time of printing. Christie makes no warranty of any kind with regard to this material, including, but not limited to, implied warranties of fitness for a particular purpose. Christie will not be liable for errors contained herein or for incidental or consequential damages in connection with the performance or use of this material. Canadian manufacturing facility is ISO 9001 and 14001 certified.

WARRANTY

Products are warranted under Christie's standard limited warranty, the complete details of which are available by contacting your Christie dealer or Christie. In addition to the other limitations that may be specified in Christie's standard limited warranty and, to the extent relevant or applicable to your product, the warranty does not cover:

- a. Problems or damage occurring during shipment, in either direction.
- b. Projector lamps (See Christie's separate lamp program policy).
- c. Problems or damage caused by use of a projector lamp beyond the recommended lamp life, or use of a lamp other than a Christie lamp supplied by Christie or an authorized distributor of Christie lamps.
- d. Problems or damage caused by combination of a product with non-Christie equipment, such as distribution systems, cameras, DVD players, etc., or use of a product with any non-Christie interface device.
- e. Problems or damage caused by the use of any lamp, replacement part or component purchased or obtained from an unauthorized distributor of Christie lamps, replacement parts or components including, without limitation, any distributor offering Christie lamps, replacement parts or components through the internet (confirmation of authorized distributors may be obtained from Christie).
- f. Problems or damage caused by misuse, improper power source, accident, fire, flood, lightning, earthquake or other natural disaster.
- g. Problems or damage caused by improper installation/alignment, or by equipment modification, if by other than Christie service personnel or a Christie authorized repair service provider.
- h. Problems or damage caused by use of a product on a motion platform or other movable device where such product has not been designed, modified or approved by Christie for such use.
- i. Problems or damage caused by use of a projector in the presence of an oil-based fog machine or laser-based lighting that is unrelated to the projector.
- j. For LCD projectors, the warranty period specified in the warranty applies only where the LCD projector is in "normal use" which means the LCD projector is not used more than 8 hours a day, 5 days a week.
- k. Except where the product is designed for outdoor use, problems or damage caused by use of the product outdoors unless such product is protected from precipitation or other adverse weather or environmental conditions and the ambient temperature is within the recommended ambient temperature set forth in the specifications for such product.
- l. Image retention on LCD flat panels.
- m. Defects caused by normal wear and tear or otherwise due to normal aging of a product.

The warranty does not apply to any product where the serial number has been removed or obliterated. The warranty also does not apply to any product sold by a reseller to an end user outside of the country where the reseller is located unless (i) Christie has an office in the country where the end user is located or (ii) the required international warranty fee has been paid.

The warranty does not obligate Christie to provide any on site warranty service at the product site location.

PREVENTATIVE MAINTENANCE

Preventative maintenance is an important part of the continued and proper operation of your product. Please see the Maintenance section for specific maintenance items as they relate to your product. Failure to perform maintenance as required, and in accordance with the maintenance schedule specified by Christie, will void the warranty.

REGULATORY

The product has been tested and found to comply with the limits for a Class A digital device, pursuant to Part 15 of the FCC Rules. These limits are designed to provide reasonable protection against harmful interference when the product is operated in a commercial environment. The product generates, uses, and can radiate radio frequency energy and, if not installed and used in accordance with the instruction manual, may cause harmful interference to radio communications. Operation of the product in a residential area is likely to cause harmful interference in which case the user will be required to correct the interference at the user's own expense.

CAN ICES-3 (A) / NMB-3 (A)

이 기기는 업무용 (A 급) 으로 전자파적합등록을 한 기기이오니 판매자 또는 사용자는 이점을 주의하시기 바라며 , 가정 외의 지역에서 사용하는 것을 목적으로 합니다 .

Environmental

The product is designed and manufactured with high-quality materials and components that can be recycled and reused. This symbol  means that electrical and electronic equipment, at their end-of-life, should be disposed of separately from regular waste. Please dispose of the product appropriately and according to local regulations. In the European Union, there are separate collection systems for used electrical and electronic products. Please help us to conserve the environment we live in!

Content

- Introduction 6**
 - Safety and warning guidelines6
 - Installation safety and warning guidelines7
 - AC/power precautions7
 - Lamp precautions8
 - Product safety labels9

- Installation and Setup 11**
 - Site requirements11
 - Physical operating environment11
 - External exhaust ducting11
 - Power connection11
 - Tools required for installation11
 - Projector components12
 - Lamp power supply components14
 - Position the projector15
 - Install the lamp power supply in a rack stand15
 - Connect the lamp power supply17
 - Configuring ballast settings for 200 VAC operation20
 - Configuring ballast settings for 400 VAC operation20
 - Adjust the projector tilt and level22
 - Install the foot extension rods22
 - Install the touch panel controller23
 - Remove the projector shroud24
 - Set up the lens25
 - Setup the lamp26
 - Touch panel controller26

- Connect Devices 27**
 - Input video mapping27
 - Four-Port: 3GIC, TDPIC, THIC cards27
 - Four-Port: DDIC card28
 - Two-Port: TDPIC card28
 - Two-Port: DDIC card28
 - Connect a video source using DisplayPort29

Connect a video source using 3G input card29

Connect a video source using HDMI30

Connect a video source using DVI30

Select a video source31

Connect a computer or server31

Set up Ethernet31

D4K3560 signal connectivity33

Operation 34

 Projector LED status indicators34

 Turn the projector on34

 LED expected behavior on power up35

 Turn the projector off35

Introduction

This manual is intended for professionally trained operators of Christie high-brightness projection systems. These operators are qualified to replace the lamp and air filters, but should not attempt to install or service the projector.

Only qualified Christie technicians who are knowledgeable about the hazards associated with high-voltage, ultraviolet exposure, and the high temperatures generated by the projector lamp are authorized to assemble, install, and service the projector.

For detailed installation, operation, maintenance, and troubleshooting information, refer to the *D4K3560 User Manual (P/N: 020-101075-XX)*. For complete D4K3560 product documentation and technical support, go to www.christiedigital.com.

Safety and warning guidelines

This projector must be operated in an environment that meets the operating range specification. Use only the attachments and/or accessories recommended by Christie. Use of others may result in the risk of fire, shock, or personal injury.



Warning! Failure to comply with the following could result in death or serious injury.

- Never look directly into the projector lens or at the lamp. The extremely high brightness can cause permanent eye damage. For protection from ultraviolet radiation, keep all projector housings intact during operation. Protective safety gear and safety goggles are recommended when servicing.
- FIRE HAZARD! Keep hands, clothes, and all combustible material away from the concentrated light beam of the lamp.



Caution! Failure to comply with the following could result in minor or moderate injury.

- Position all cables where they cannot contact hot surfaces or be pulled or tripped over.
- The American Conference of Governmental Industrial Hygienists (ACGIH) recommends occupational UV exposure for an 8-hour day to be less than 0.1 microwatts per square centimeters of effective UV radiation. A workplace evaluation is advised to assure employees are not exposed to cumulative radiation levels exceeding the government guidelines for your area. Be aware that some medications are known to increase sensitivity to UV radiation.

NOTE: During maintenance and cleaning operations, the instructions define that the unit must not be operational, thus the lamps are not active and there are no emissions. Optical adjustments are not considered maintenance. The lamps are turned on during optical adjustments and emissions are present.

Installation safety and warning guidelines



Danger! Failure to comply with the following results in death or serious injury.

- This product must be installed within a restricted access location where equipotential bonding is provided, which is normally inaccessible by the general public, including workers, visitors, and residents in the immediate vicinity, by means of engineering or administrative control measures but is accessible to authorized personnel that may not have specific safety training.
- This product must be located and positioned in a way as to restrict audience members from direct access to enter the light beam path.
- Do not install the projector overhead.
- When installing the projector in portrait mode, the device holding the projector must have a weight rating sufficient to hold the weight of the projector. The projector weighs 125kg (275 lbs).
- The projector uses a high-pressure lamp that may explode if improperly handled. Always wear manufacturer approved protective safety clothing (gloves, jacket, face shield) when the lamp door is open or when handling the lamp. Failure to comply results in death or serious injury.



Warning! Failure to comply with the following could result in death or serious injury.

- A qualified technician is required for all installations.
- SHOCK HAZARD. Never operate the projector without all of its covers in place.
- Use of the projector's rear safety strap is **mandatory** to prevent the projector from tipping. Secure the strap between the projector and the surface it is mounted to.
- Four or more people are required to safely lift and hand-carry one projection head a short distance. Christie recommends removing the lamp before transporting the projector.
- Two or more people are required to safely lift and hand-carry the lamp power supply (LPS).



Notice. Failure to comply with the following may result in property damage.

- Perform an automatic LampLOC adjustment when the lamp is moved, leveled, or a new lamp is installed in the projector.
- Keep the projector level when lifting or transporting. Avoid tilting the projector to the right. This can introduce an air bubble into the coolant hoses that can result in an air lock and the overheating of the projector.

AC/power precautions

To correctly install this projector, a certified electrician must install a permanent three-phase connection to the lamp power supply (LPS). The LPS projector outlet is used to supply power to the projector head. Operate the projector at the recommended voltage.



Danger! Failure to comply with the following results in death or serious injury.

Disconnect projector from AC before opening any enclosure.



Warning! Failure to comply with the following could result in death or serious injury.

- Verify that the projector is using a line cord, socket, and power plug that meets the appropriate local rating standards. Use only an AC power cord recommended by Christie. Do not attempt operation if the AC supply and cord are not within the specified voltage and power range.
- Do **not** allow anything to rest on the power cord. Locate the projector where the cord cannot be abused by persons walking on it or objects rolling over it. Never operate the projector if the power cable appears damaged in any way.
- Do **not** overload power outlets and extension cords as this can result in fire or shock hazards.

Lamp precautions

Lamps used in the projector are under high pressure and must be handled with caution. Lamps can explode and cause serious personal injury if dropped or mishandled.



Danger! Failure to comply with the following results in death or serious injury.

- Never attempt to access the lamp compartment while the lamp is on. Wait at least 10 minutes after the lamp turns off before powering down, disconnecting from AC, and opening the lamp door.
- The arc lamp operates at a high pressure that increases with temperature. Failure to allow the lamp to sufficiently cool before handling, increases the potential for an explosion causing personal injury or property damage.
- Always wear manufacturer approved protective safety clothing (gloves, jacket, face shield) when the lamp door is open or when handling the lamp. Only qualified technicians should install projector lamps.



Warning! Failure to comply with the following could result in death or serious injury.

- Possibly hazardous optical radiation emitted from this product. (Risk group 3)
- Thermal radiation emitted from this product may cause burns. (Risk group 3)



Recommended protective clothing includes, but may not be limited to a polycarbonate face shield, protective gloves, and a quilted ballistic nylon jacket or a welder's jacket. This equipment is included in included in the Christie Protective Clothing Safety kit
P/N: 598900-095.

Christie's protective clothing recommendations are subject to change. Any local or federal specifications take precedence over Christie recommendations.

Product safety labels



Indicates the presence of a grounding point.



Indicates the presence of an earth grounding point.



Indicates the presence of a dangerous condition or situation.



Indicates the presence of a pinch hazard. To avoid personal injury, keep hands clear and loose clothing tied back.



Indicates the presence of a hot surface. To avoid personal injury, always allow the projector to cool down for a minimum of 10 minutes before performing maintenance or service procedures.



Indicates the presence of a hot surface. To avoid personal injury, always allow the projector to cool down for a minimum of 10 minutes before performing maintenance or service procedures.



Indicates the presence of an electrical shock hazard. To avoid personal injury, always disconnect all power sources before performing maintenance or service procedures.



Indicates the presence of an electrocution hazard. To avoid personal injury, always disconnect all power sources before performing maintenance or service procedures.



Indicates the presence of moving fan blades. To avoid personal injury, keep hands clear and loose clothing tied back. Always disconnect all power sources before performing maintenance or service procedures.



Indicates exposure to bright light. To avoid personal injury, never look directly at the light source.



Indicates the presence of an explosion hazard. To avoid personal injury, always disconnect all power sources and wear Christie approved protective clothing.



Indicates the presence of a fire hazard. To avoid personal injury and property damage, always adhere to the instructions described in this manual.

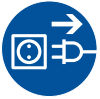

Always disconnect all power sources before performing maintenance or service procedures.



See the product user manual for specific information and directions.



See the product service manual for specific information and directions.



Never look directly into the projector lens. The extremely high brightness can cause permanent eye damage.



Indicates possible optical radiation emitted from the product.

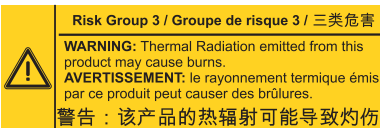

Indicates thermal radiation emitted from the product may cause burns.

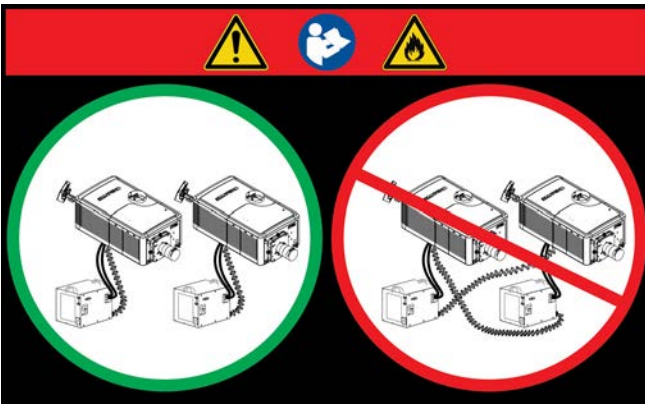

This label warns of a cross-connection hazard when installing multiple projectors at once. A fire hazard exists if a lamp power supply interlock cable is connected to a different projector than its lamp power cables.

Installation and Setup

Learn how to install, connect, and optimize the projector display.

Site requirements

To safely install and operate the projector, the installation location must have restricted access for authorized personnel only and meet these minimum requirements.

Physical operating environment

Provides specifications for the operating environment.

- Maximum ambient temperature (operating) 35°C (95°F)
- Minimum ambient temperature (operating) 10°C (50°F)

External exhaust ducting

The installation site must provide a minimum of 450 CFM (ft³/min) external exhaust airflow to ensure adequate cooling of the Xenon arc lamp at less than or equal to 25°C (77°F) ambient and less than 3,000 ft (914.4 m) elevation. Above 25°C or 3,000 ft, 600 CFM is required.

Power connection

The requirements listed below are applicable for permanently wired installation or power cord connection:

- Single phase 15A IEC320C14 (lamp power supply to projector head)
- Terminal block, electrician hard-wired to the projector head.
Three-phase, 38A 200-230VAC + Earth (North America and Japan)
or
Three-phase, 26A 380-415VAC + Neutral + Earth (regions outside North America and Japan)
- This product can be connected to an IT power distribution system.

Tools required for installation

- 12" screwdrivers: Phillips #2 (magnetic) and flat

- 19 mm and 7/8” wrenches
- Assorted Allen keys (metric)
- Christie approved protective safety clothing if working with the lamp
- Lens cleaning tissue and solution

Projector components

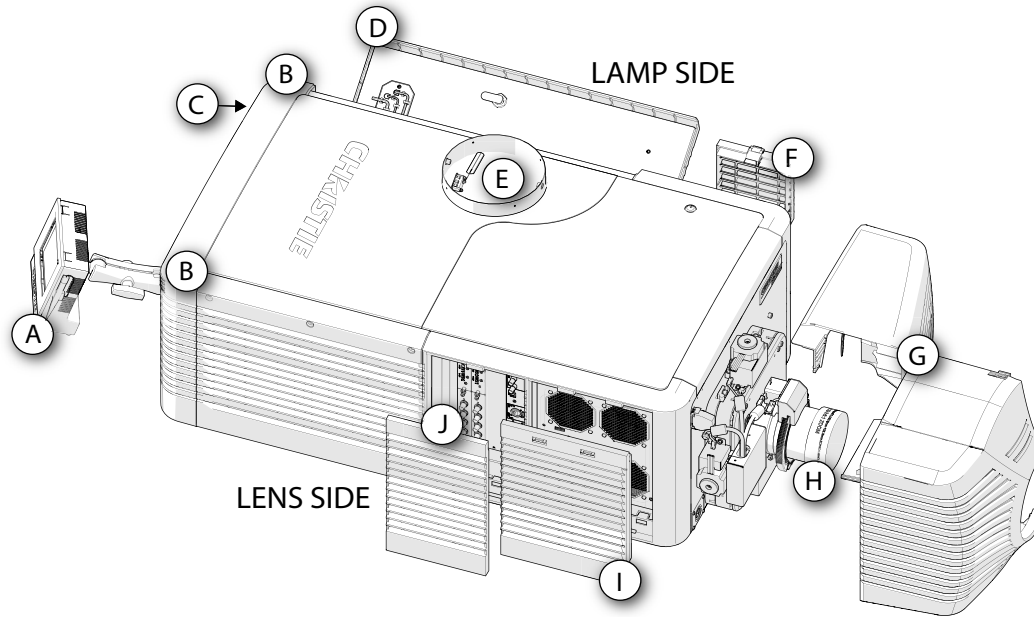

ID	Description	
A	Touch panel controller (TPC)	A touch-sensitive screen used to control and monitor operation.
B	LED status indicators	LED color and blinking rates (located in both back corners of the projector) provide information about the status of the projector using color and blinking rates. For information about projector states and status, see Projector LED status indicators on page 34 .
C	Manual douser override	Closing the douser rotates a shutter blade in front of the lamp and reduces the lamp power to 2.0 kW to conserve lamp life. The override is for emergency use only.
D	Lamp door and lamps	The lamp door provides access to the lamp compartment and must remain closed and locked for normal operation. Lamp replacement should only be performed by qualified technicians. For a complete list of available lamp types, see the D4K3560 User Manual (P/N: 020-101075-XX) .
E	Exhaust duct and vane switch	Extracts heated air from the lamp compartment. The vane switch mounted inside the rigid port monitors airflow. See Site requirements on page 11.
F	Liquid cooling air filter cover and air filter	Filters air before it circulates to cool the heat exchanger.

ID		Description
G	Shroud (two-piece)	The shroud covers the motorized lens mount assembly.
H	Projection lens	A variety of projection lenses can be used with the projector. For a list of available lenses, see the D4K3560 User Manual (P/N: 020-101075-XX) .
I	Air filter cover and air filter	Filters the intake air before it circulates through the front compartment to cool the main electronics.
J	Input panel faceplate	Provides a variety of ports for connecting external devices. For information about connecting devices and inputs, see Connect Devices on page 27.

Lamp power supply components

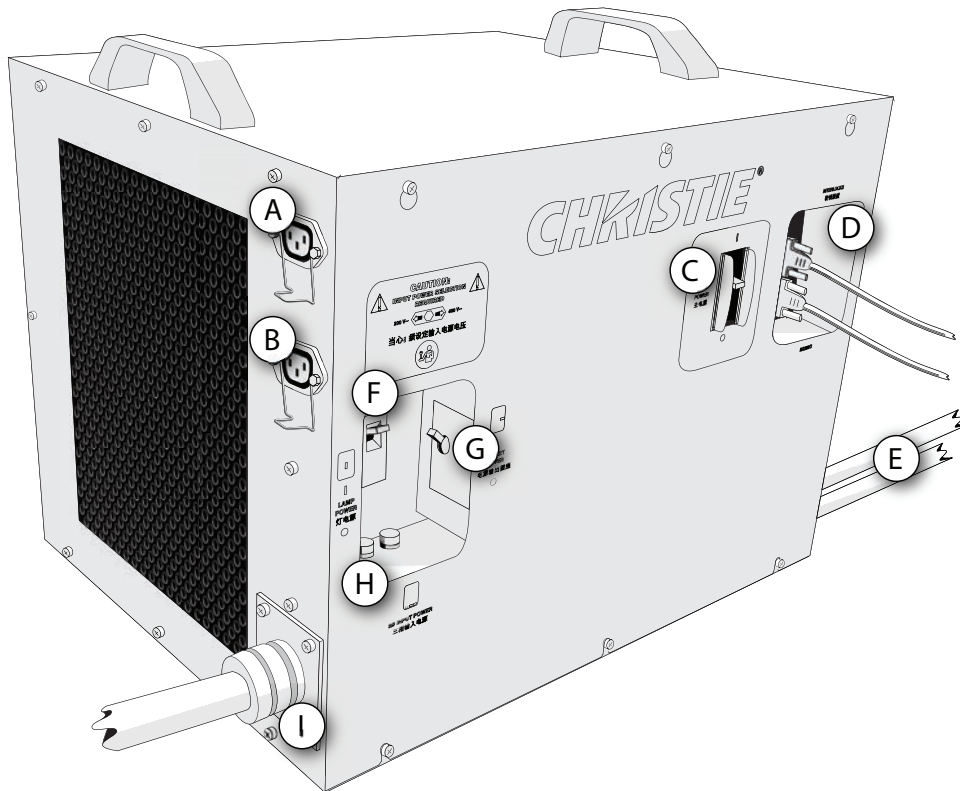

ID	Item	Description
A	Extractor AC power outlet	Powers an approved extractor unit. Do not use this outlet to power other devices.
B	Projector AC power outlet	Powers the projector head. Do not use this outlet to power other devices.
C	Main LPS breaker	Acts as a power switch, protecting the lamp power supply (LPS) against over-current conditions of 50A or more.
D	Projector interlock and communication connections	Provides communication between the projector and the LPS.
E	DC lamp power cables	Carries power from the LPS to the projection lamp.
F	Lamp breaker	Acts as a power switch, protecting the LPS against over-current conditions of 50A or more.
G	Outlet breaker	Acts as a power switch, protecting the extractor and the projector electronics against over-current conditions of 15A or more.
H	Power phase indicator lights	Indicates the power on each of the three phases.
I	LPS power inlet	Supplies power to the LPS. This connection must be professionally wired, according to local regulations.

Position the projector

1. Position the projector at an appropriate throw distance (projector-to-screen distance) and vertical position. Ideally, center the projector with the screen. If space is limited, aim the projector slightly off-center. This increases side keystone, but reduces the horizontal lens offset required.

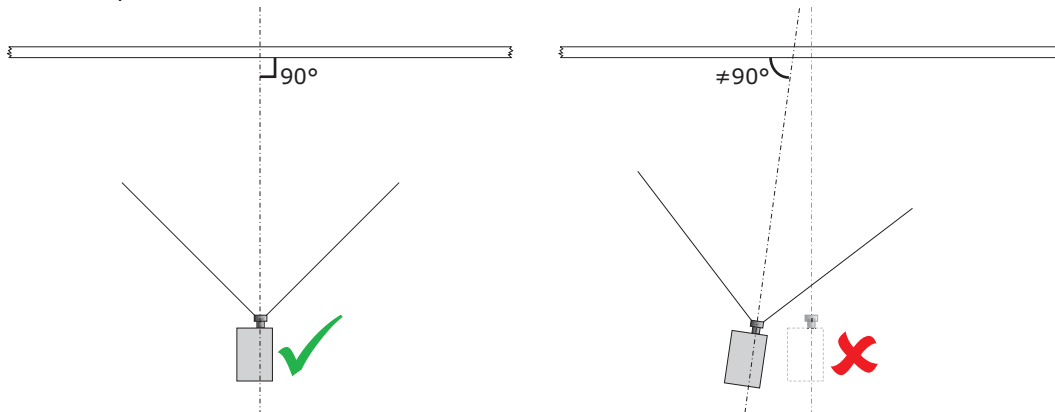

Keep the projector lens as perpendicular to the screen as possible, even if significantly above the screen center. When a particularly short throw distance combines with a wide screen, you may have to forfeit some aim and stay more perpendicular to the screen. In such cases, some lens offset can reduce the keystone distortion.

2. Position the lamp power supply (LPS) so its cables reach the lens side of the projector.
3. If using an optional rack stand (P/N: 108-282101-02), assemble the rack stand using the instructions provided with the rack stand. Use the hold down clamp (P/N: 116-100101-01) when securing the projector to the rack stand.

Install the lamp power supply in a rack stand

1. Remove the right (operator's side) panel of the rack stand.
2. Remove the cross bar.
3. Insert the lamp power supply (LPS) support into the rack stand and align the pins with the holes.
4. Lift the LPS into the frame.
5. Remove the bottom 10 panels from the back of the rack stand.

6. Assemble the three-piece airflow duct (supplied with LPS). First snap the two L shaped parts together, and then snap this into the six stand out pins of the third piece (flat panel).

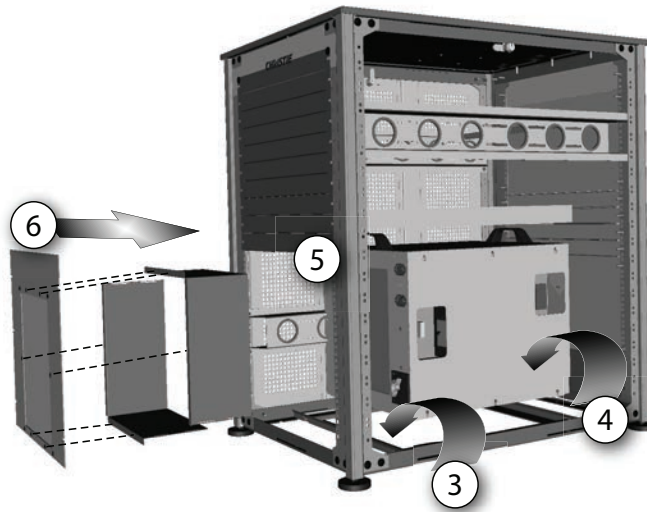

7. Position the airflow duct directly behind the LPS.



Do not install any components in front of the lamp power supply that will restrict airflow.

8. Insert airflow duct into rack stand from the outside.
9. Secure airflow duct to rack stand using screws from the rack stand panels.
10. When installing other components in the rack stand allow at least two inches of clearance above the LPS handles for ease of servicing.

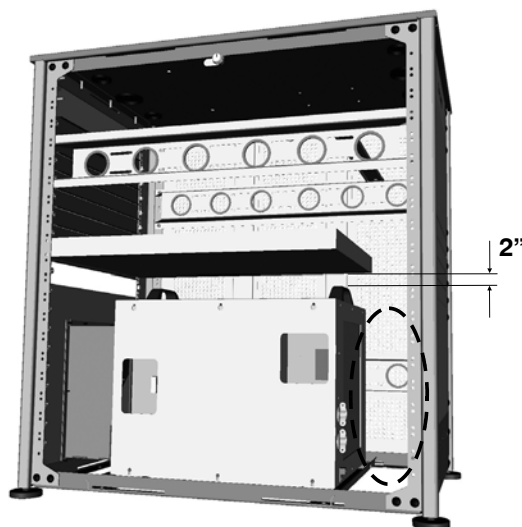

11. Wire all components within the rack stand and replace the side panel.

Connect the lamp power supply



Danger! Failure to comply with the following results in death or serious injury.



In a multi-projector installation there is a risk of a **Fire Hazard** if the high current DC cables and interlock/control cables are incorrectly cross-connected between the projector heads and lamp power supplies (LPSs).

To avoid cross connections between projectors and lamp power supplies, always perform this procedure in its entirety for each projector, one after another. Never attempt to connect multiple projectors and lamp power supplies together at the same time.

Before powering the projector on for the first time, check that the high current DC leads and interlock/control cables are correctly connected between the LPS and its corresponding projector. Failure to comply may result in a Fire Hazard.



Warning! Failure to comply with the following could result in death or serious injury.

- Certified electrician required during installation. Ground (earth) connection is necessary for safety. Never compromise safety by returning the current through the ground. Connect ground first to reduce shock hazard.
- Use an appropriate strain relief connector on the AC supply cable to prevent the cable from rubbing against the LPS knockout plate and becoming damaged.

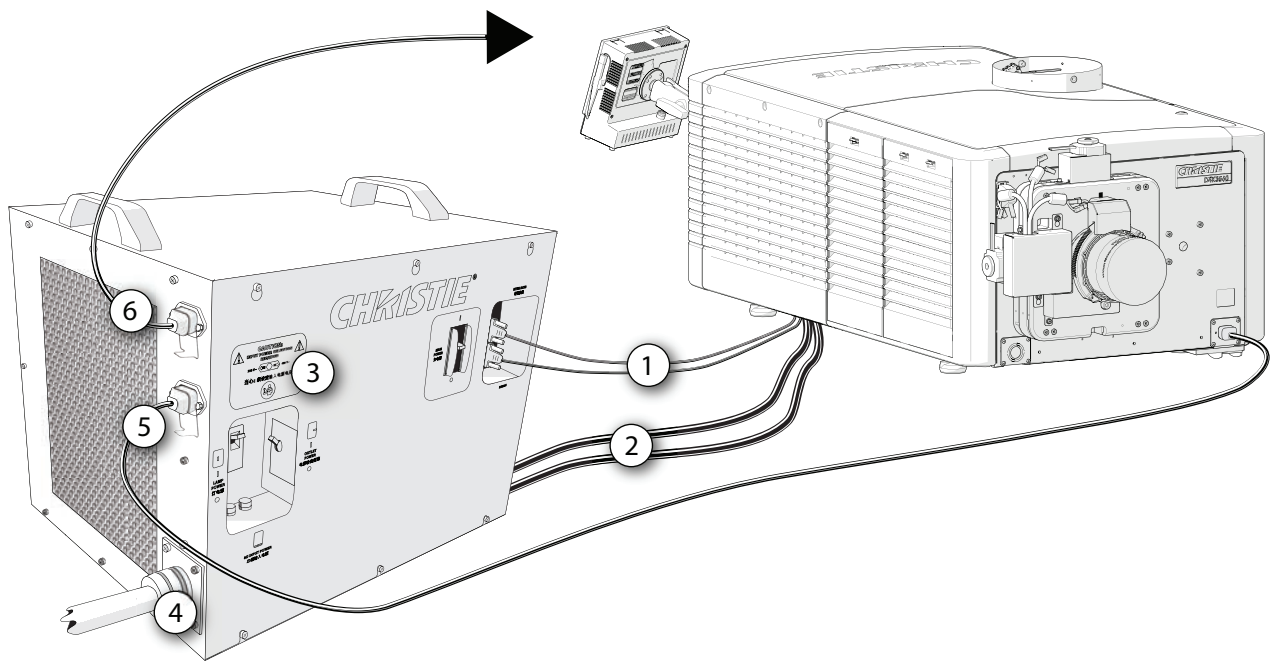

1. Ensure the power is disconnected from the lamp power supply (LPS).
2. Loosen three screws to remove the rear lens-side cover.
3. Connect the LPS communication cables:
 - a. Connect one end of the RS232 cable to the lower port on the LPS labeled **RS232**.
 - b. Connect one end of the Interlock cable to the upper port on the LPS labeled **Interlock**.

- c. Connect the projector end of the cable to the port labeled **RS232**, located on the underside of the projector chassis.
 - d. Connect the projector end of the Interlock cable to the port labeled **Interlock**, located on the underside of the projector chassis.
4. Connect the LPS lamp leads:
- a. Route the positive (+) cable through the upper strain relief in the LPS cover.
 - b. Route the negative (-) cable through the lower strain relief in the LPS cover.
 - c. Connect the positive (+) and negative (-) lamp leads to the terminals on the LPS.
 - d. Tighten the strain reliefs.
 - e. Pull the spring plunger to open the igniter door. The door can also be lifted off the hinges to remove it completely.
 - f. Route the positive (+) and negative (-) leads from the LPS through the two strain reliefs in the projector baseplate.
 - g. Connect the negative (-) black lamp lead to the negative (-) igniter terminal, left terminal. Connect the positive (+) red lamp lead to the positive (+) igniter terminal, right terminal.



Caution! Failure to comply with the following could result in minor or moderate injury.

When connecting the high current lamp leads between the LPS and the igniter, make sure the black (-) power cable (cathode lead) is securely connected with the washers and lock washers properly in place and tighten to 175 inch-lbs, 14 ft-lbs or 20Nm at both ends.

- h. Tighten the strain reliefs.
 - i. Replace the igniter door.
 - j. Replace the rear lens-side cover.
5. Ensuring AC power is off at the supply, connect the AC directly to the LPS AC input terminal block according to your region.



Caution! Failure to comply with the following could result in minor or moderate injury.

Use an appropriately sized strain relief connector with the knockout plate provided to ensure adequate environmental sealing and to prevent the cable from accidentally being torn out.

- For North America, Japan, Korea and most of Central/South America (200-230 VAC):
Wire Phase 1, 2, 3 and Ground
 - For Europe and China (380-415 VAC):
Wire Phase 1, 2, 3, Neutral and Ground
- a. Loosen the six screws to remove the LPS side panel.
 - b. Move the AC input line voltage switch in the upper-left corner of the LPS to the left. When using a 200 VAC supply, see [Configuring ballast settings for 200 VAC operation](#) on page 20, or to the right when using a 400 VAC supply see [Configuring ballast settings for 400 VAC operation](#) on page 20.

- c. Reinstall and secure the LPS side panel with six screws.



Notice. Failure to comply with the following may result in property damage.
Internal input line voltage switch setting must match AC available on site.

6. Connect one end of the line cord into the LPS power connector labeled **Projector ONLY**.

If using the longer DC cable kits, the projector head must be powered separately using Christie recommended line cord provided for your region.

7. Connect the other end of the projector line cord into the plug on the bottom lamp-side of the projector front bezel.



Warning! Failure to comply with the following could result in death or serious injury.
Do **not** access projector power directly from the building electrical source. When using the power connectors to power the projector and/or an extraction unit, the power connector terminal block must be terminated correctly to allow 200 - 240 VAC output. These connectors are controlled with the power connector breaker. For details, see the Interconnect Drawing provided with the projector.

8. If using a Christie extractor, connect the line cord to the LPS connector labeled **Extractor ONLY**.
9. Verify the LPS to projector connections by making sure that all cables connected to the LPS are connected to the same projector.

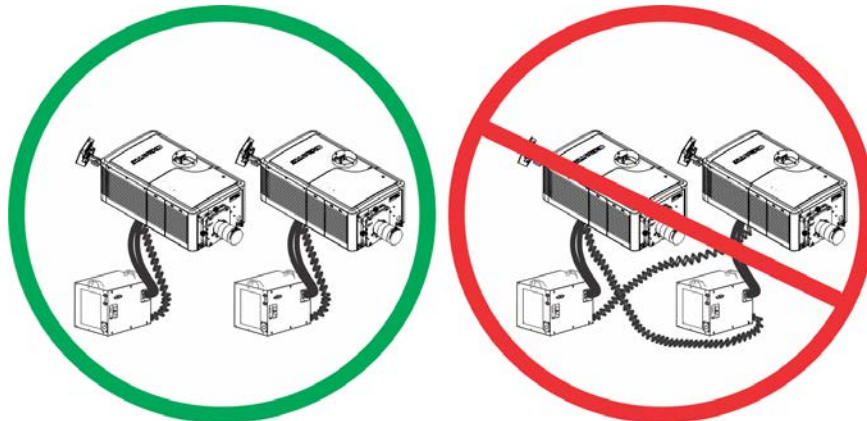

Danger! Failure to comply with the following results in death or serious injury.
In a multi-projector installation there is a risk of a Fire Hazard if the high current DC cables and interlock/control cables are incorrectly cross-connected between the projector heads and lamp power supplies (LPSs). Make sure the high current DC LIDs and interlock/control cables are correctly connected between the LPS and its corresponding projector. Failure to comply may result in a Fire Hazard.

10. Set the three LPS breakers to their on positions.
11. Set the projector breaker, located on the baseplate below the projector AC receptacle, to the on position.

Configuring ballast settings for 200 VAC operation

1. Unplug the LPS from power.
2. Remove the front panel using a Phillips screwdriver.
3. Insert the convenience outlet harness (black) wire into the first position on the terminal block.

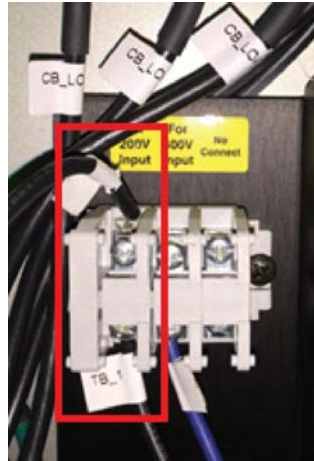

4. Tighten the screw to secure the harness in place.
Ensure the wire insulation is not crimped under the screw.
5. Slide the selector switch to the **200V** location.



6. Re-attach the front panel.

Configuring ballast settings for 400 VAC operation

1. Unplug the LPS from power.

2. Remove the front panel using a Philips screwdriver.
3. Insert the convenience outlet harness (black) wire into the second position on the terminal block.

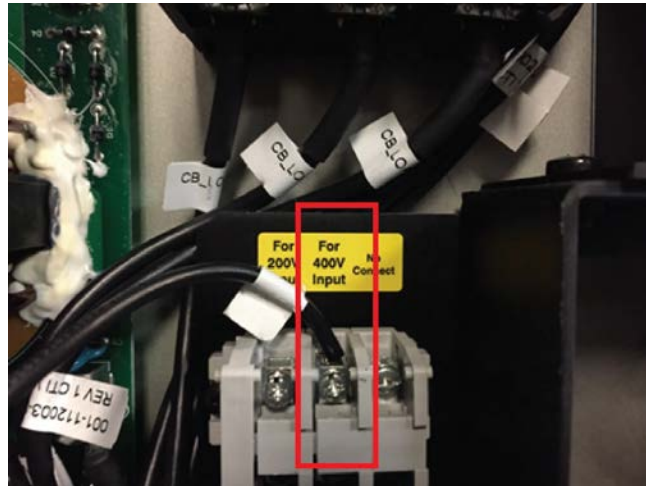

4. Tighten the screw to secure the harness in place.
Ensure the wire insulation is not crimped under the screw.
5. Slide the selector switch to the **400V** location.



6. Re-attach the front panel.

Adjust the projector tilt and level



Warning! Failure to comply with the following could result in death or serious injury.

- The projector's rear safety strap must be in place before adjusting the projector feet.
- Do not over-extend the feet. Make sure several threads are engaged into the projector's baseplate to secure the projector from falling.

Adjust the projector tilt to fill the maximum amount of screen while minimizing keystone. Lens offset can be used to center the image in the center of the screen..



Notice. Failure to comply with the following may result in property damage.

The front-to-back tilt of the projector must not exceed 15 degrees.

1. Secure a safety lifting strap rated to handle the projector weight at the rear of the projector.
2. Hoist up the projector.
3. To adjust the vertical or horizontal position of the projector, extend or retract the adjustable feet on the bottom of the projector (A).
4. Once the required adjustment is made, tighten the lock nut against the bottom of the projector (B).

The projector provides 4 inches of adjustment at the front and 11.5 inches of adjustment at the rear.

5. If the vertical or horizontal position of the projector requires more adjustment than the standard feet allow, two 6-inch extension rods can be installed to increase the amount of available adjustment.

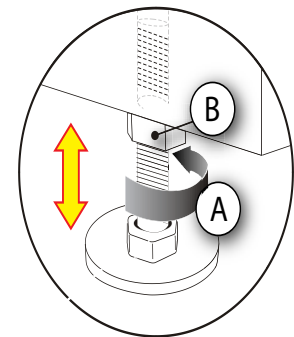

Install the foot extension rods

1. Elevate the rear of the projector to access the two rear feet.
2. Remove the feet by loosening the lock nut and rotating the each foot out of the projector.
3. Add the extension rods to the standard feet.
4. Thread the extended feet into the projector's baseplate.
5. Adjust the feet until the required tilt is achieved.

- Lock the feet in place by turning each lock nut until it fits tight against the projector.

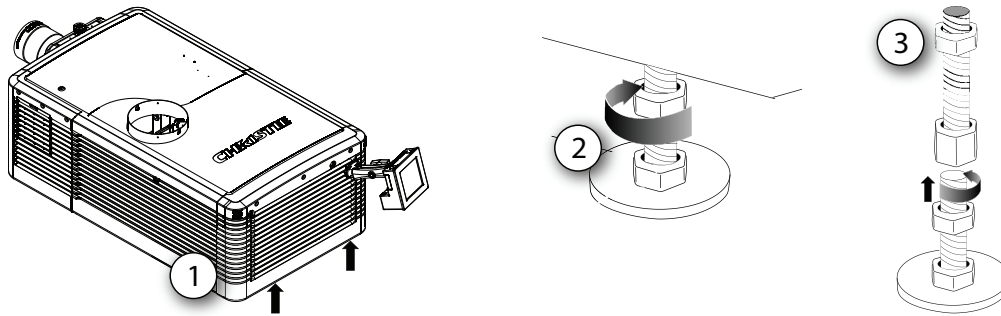

Install the touch panel controller

- Loosen the mounting arm just enough for the end to fit over the ball joint located on the rear panel of the projector.
The touch panel controller (TPC) becomes loose from the mounting arm when the mounting arm lock is loosened.
- Tighten the mounting arm lock until it fits tightly on the joint.
The TPC safety strap comes installed on the projector ball point.
- Connect the cable from the touch panel controller (TPC) to the connector on the rear panel of the projector.
- Adjust the TPC angle for optimal viewing, then tighten the mounting arm lock securely so that the TPC is held in place at the required location.

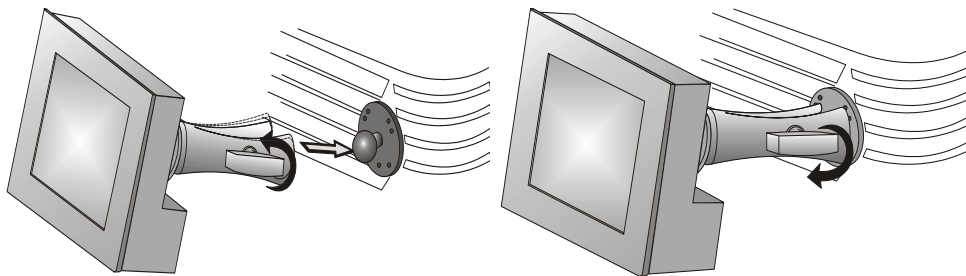

Connect external exhaust ducting



Warning! Failure to comply with the following could result in death or serious injury.

At minimum, a 10-inch (25.4 cm) long, strong metal duct must be installed at the projector and installed to an outside venting duct system to prevent glass shards from exiting the duct in the event of a lamp explosion.



Notice. Failure to comply with the following may result in property damage.

*600 CFM is required in projection rooms with an ambient temperature above 25°C or located at an elevation greater than 3000 feet above sea level.

Connect the existing outside-venting duct to the 8-inch diameter exhaust port on the top of the projector. Make sure there are no obstructions or bends in the ducting or air intakes and the vane switch at the exit duct moves freely.

The pre-installed outside-venting duct should be rigid at the projector and must also include a heat extractor and blower that maintains a minimum of 450 CFM* when the projector is operating at less than or equal to 25°C (77°F) ambient and less than 3,000 feet (914.4 m), when measured at the projector exhaust opening.

To determine the projector exhaust CFM value, use an airflow meter to measure the ft/min at the rigid end of the open exhaust duct that connects to the projector. Take the measurement at the end of the duct without the projector connected.

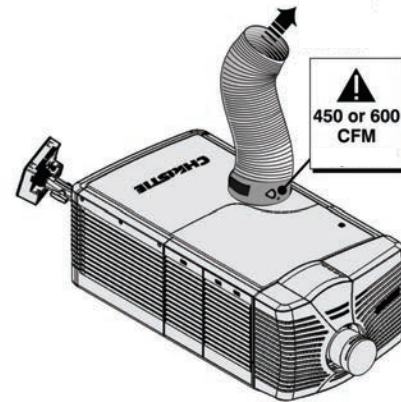

Use this formula to determine the CFM value for the projector: $CFM = 0.35 \times \text{Measured ft/min}$

Lamp Type	Min. Airflow (CFM) Required
2.0 kW	450 CFM*
3.0 kW	450 CFM*
4.5 kW	600 CFM
6.0 kW	600 CFM

*600 CFM is required in projection rooms with ambient temperature above 25°C (77°F) or elevation (above sea level) greater than 3000 feet (914.4 m).

Add an extractor or a booster if there is insufficient airflow. Do not mount the extractor on the projector as this may introduce some vibration into the image.



Notice. Failure to comply with the following may result in property damage.

Never disable the vane switch. Attempting to operate the projector with inadequate airflow can result in dangerous overheating of the projector.



To prevent the projector from overheating or becoming unsafe, an alarm sounds if the duct is obstructed or a fan fails. Christie recommends regularly verifying that the exhaust is unobstructed and functioning correctly.

Remove the projector shroud



Warning! Failure to comply with the following could result in death or serious injury.

- Never install the shroud for overhead installations.

The lens side shroud must be removed to gain access to the lens. The other shroud must be removed when connecting the AC power cord into the front face of the projector.

1. Use finger pressure to push down on the shroud clips located at the top and bottom of the shroud as shown by the arrows.

- Carefully slide the shroud sideways and forward away from the lens mount and lens.

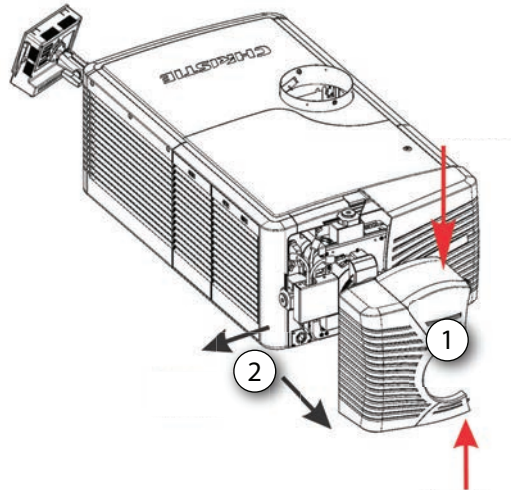

- Place the shroud covers on a clean surface to prevent scratches.

Set up the lens



Warning! Failure to comply with the following could result in death or serious injury.

- Keep fingers and other body parts away from the moving parts in the projector. Motors and fans may start without warning.
- Tie back long hair, remove jewelry and loose clothing before manually adjusting the projector.



Notice. Failure to comply with the following may result in property damage.

The lens seals the projection head, preventing contaminants from entering the main electronics area. Do not operate the projector without a lens installed. Use a lens plug when installing or transporting the projector.

1. Remove the projector shroud.
2. Make sure the lens locking lever is in the up position.
3. If attached, remove the rear lens cap from the lens.
4. Slide the lens into the lens mount, aligning all connections.



Always install the lens with UP label in the top position to achieve consistent boresight alignment each time the lens is replaced.

5. Secure the lens with the lens locking lever (down position).
6. Calibrate the lens motors.

Setup the lamp

The lamp position can be adjusted at any time, using a set of electronically controlled motors. An optimal position for the lamp, with respect to the reflector and the integrator rod, results in maximum brightness. This geometry is software controlled using the LampLOC calibration process.

Touch panel controller

The touch panel controller (TPC) is a touch-sensitive screen. Use the TPC to control the projector, manage sources, adjust the display, and view status information. The TPC is mounted on the rear of the projector and can be adjusted to improve the TPC viewing angle. A side USB port can be used to download log files and install software upgrades.

For remote applications, the TPC can be dismantled from the projector and used with the optional cable to allow projector control from a maximum distance of 100 ft (30 m).

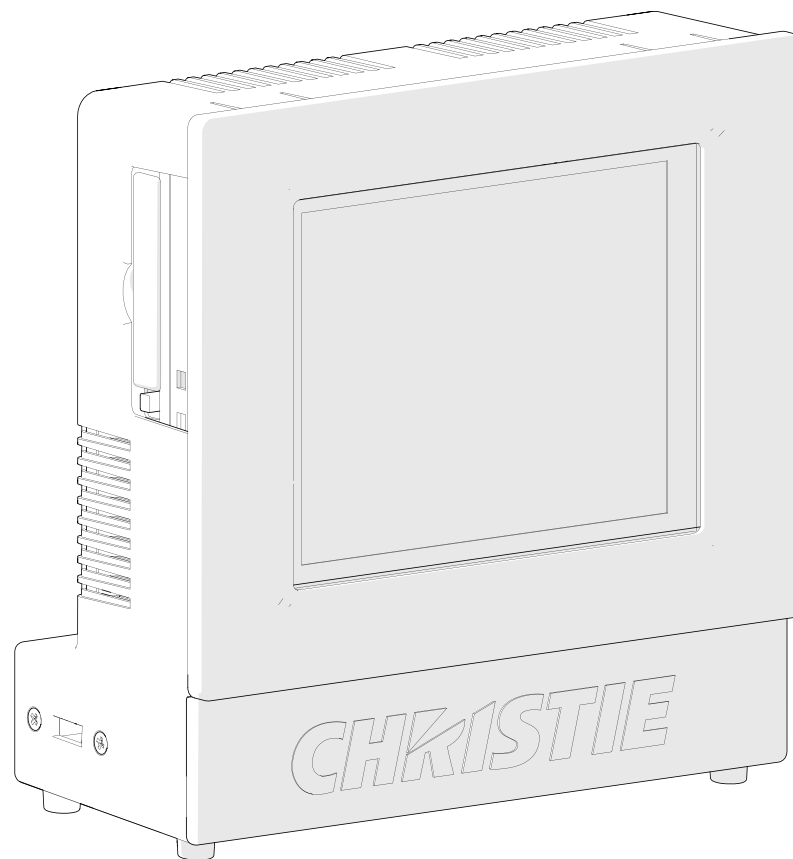

Connect Devices

This section provides information and procedures for connecting external devices to the projector. Communication and input ports are located on the projector side input panel, accessed by removing the input panel cover. When connecting devices, you can route cables through the opening in the frame to the side input panel or directly to the video option cards and MCU. The image below shows the video option card slot numbers and the MCU panel.

Input signal devices are connected to the video option cards and the option card slot numbers are important for some types of input signals. Communication devices are connected at the MCU panel.

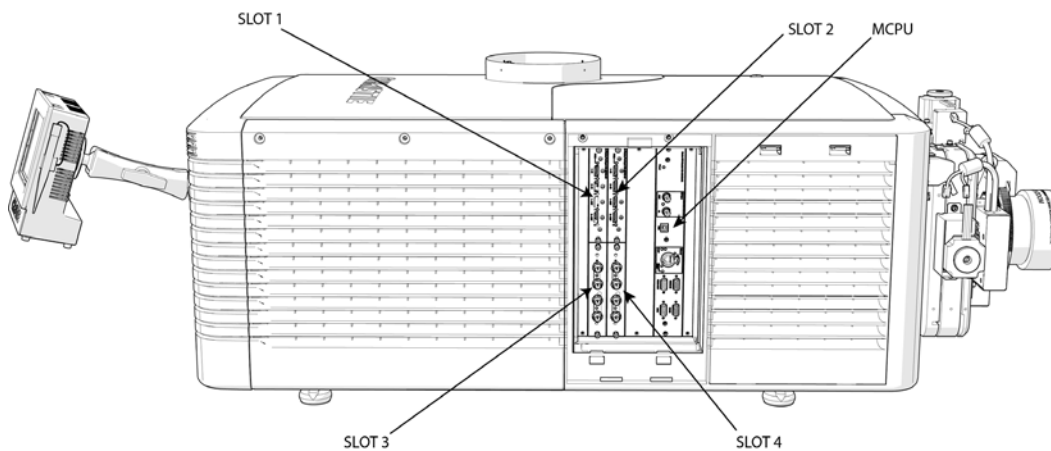

Input video mapping

Video input mapping depends on the type of cards used for the Four-Port or Two-port input configurations.

Four-Port: 3GIC, TDPIC, THIC cards

The following table shows the video quadrant mappings for the 3GIC, TDPIC, and THIC Four-Port input configurations:

Four-Port input configuration—Two cards (1)		Quadrants	Columns
Slot 1	1-In	Top left	1 (left most)
Slot 1	2-In	Bottom left	2

Slot 2	1-In	Top right	3
Slot 2	2-In	Bottom right	4
Four-Port input configuration—Two cards (2)		Quadrants	Columns
Slot 3	1-In	Top left	1 (left most)
Slot 3	2-In	Bottom left	2
Slot 4	1-In	Top right	3
Slot 4	2-In	Bottom right	4
Four-Port input configuration—Four cards		Quadrants	Columns
Slot 1	1-In	Top left	1 (left most)
Slot 2	1-In	Top right	2
Slot 3	1-In	Bottom left	3
Slot 4	1-In	Bottom right	4

Four-Port: DDIC card

The following table shows the video quadrant mappings for the DDIC Four-Port input configuration:

Four-Port input configuration		Quadrants	Columns
Slot 1	1-Dual Link DVI-I	Top left	1 (left most)
Slot 2	1-Dual Link DVI-I	Top right	2
Slot 3	1-Dual Link DVI-I	Bottom left	3
Slot 4	1-Dual Link DVI-I	Bottom right	4

Two-Port: TDPIC card

The following table shows the video quadrant mappings for the TDPIC Two-Port input configuration:

Two-Port input configuration—Two cards (1)		Columns
Slot 1	1-In	1 (left most)
Slot 2	1-In	2
Two-Port input configuration—Two cards (2)		Columns
Slot 3	1-In	1 (left most)
Slot 4	1-In	2

Two-Port: DDIC card

The following table shows the video quadrant mappings for the DDIC Two-Port input configuration:

Two-Port input Configuration—Two cards (1)		Columns
Slot 1	1-Dual Link DVI-I	1 (left most)
Slot 2	1-Dual Link DVI-I	2

Two-Port input configuration—Two cards (2)		Columns
Slot 3	1-Dual Link DVI-I	1 (left most)
Slot 4	1-Dual Link DVI-I	2

Connect a video source using DisplayPort

The Twin DisplayPort input card (TDPIC) accepts digital video data from the DisplayPort sources. The input configurations listed below are supported.

Input configuration	Description	Requirements
Four-Port	Enables connection of four DisplayPort cables to two or four TDPIC cards. Each DisplayPort input supplies one quadrant or column of a 4K input image. This configuration supports high resolution and high frame rate input video streams.	Two or four TDPIC cards
Two Port	Enables connection of two DisplayPort cables to two TDPIC cards. Each DisplayPort input supplies one of two columns of a 4K input image.	Two TDPIC cards
One-Port	Enables connection of one DisplayPort cable to the 1-IN input of a TDPIC card (any slot). In this configuration the DisplayPort input supplies the entire video raster.	One TDPIC card

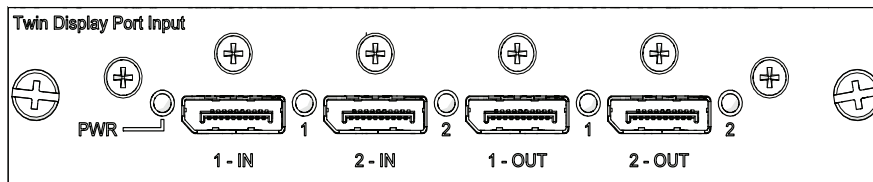

Connect a video source using 3G input card

The 3G input card (3GIC) accepts digital video data from HD and 3G-SDI (Serial Digital Interface) sources. The input configurations listed below are supported.

Input configuration	Description	Requirements
Four-Port	Enables connection of four SDI cables to two 3GIC cards. Each SDI input supplies one quadrant or column of a 4K input image. This configuration supports high resolution and high frame rate input video streams.	Two 3GIC cards
One-Port	Enables connection of one SDI cable to the 1-IN input of a 3GIC card (in any slot). In this configuration the SDI input supplies the entire video raster.	One 3GIC card

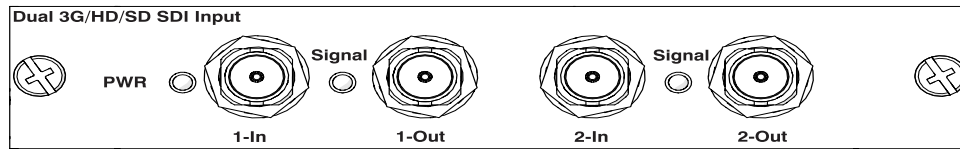

Connect a video source using HDMI

The Twin HDMI input card (THIC) accepts digital video data from HDMI sources. The input configurations listed below are supported.

Input configuration	Description	Requirements
Four-Port	Enables connection of four HDMI cables to two THIC cards. Each HDMI input supplies one quadrant or column of a 4K input image. This configuration supports high resolution and high frame rate input video streams.	Two THIC cards
One-Port	Enables connection of one HDMI cable to the 1-IN input of a THIC card (in any slot). In this configuration, the HDMI input supplies the entire video raster.	One THIC card

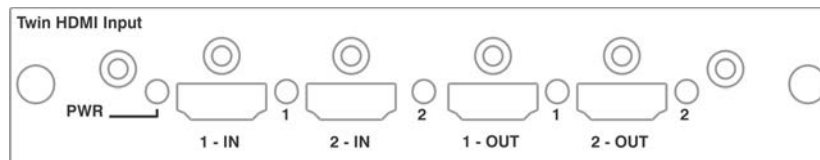

Connect a video source using DVI

The Dual Link DVI input card (DDIC) accepts digital video data from DVI sources. It does not support incoming analog signals. The input configurations listed below are supported.

Input configuration	Description	Requirements
Four-Port	Enables connection of four DVI cables to four DDIC cards. Each DVI input supplies one quadrant or column of a 4K input image. This configuration supports high resolution and high frame rate input video streams.	Four DDIC cards
Two Port	Enables connection of two DVI cables to two DDIC cards. Each DVI input supplies one of two columns of a 4K image.	Two DDIC cards
One-Port	Enables connection of one DVI cable to the DVI input of a DDIC card (in any slot). In this configuration, the DVI input supplies the entire video raster.	One DDIC card

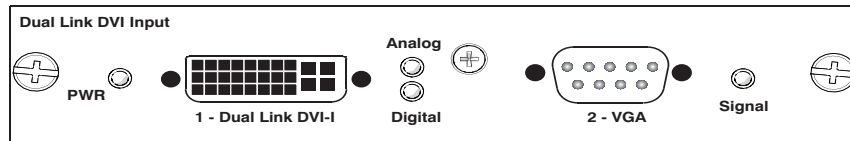

Select a video source

After connecting a video source to the projector, you must select it using the touch panel controller (TPC).

1. On the TPC, select **Input > Channel**.
2. Scroll the list of channels until you find the channel that best matches your configuration.
3. Tap the channel.

An image appears on the screen. If an image does not appear on the screen, repeat steps 1 to 3, selecting a different channel.

Connect a computer or server

To communicate with a remote computer, server or an existing network, use an RJ-45 cable to connect the Ethernet hub or switch to the Ethernet port, located on the projector MCPU faceplate. When using the Christie serial protocol over Ethernet, connect to port 3002.

For applications or equipment using serial communications, use the Christie-proprietary serial protocol to communicate with the RS422 port or the RS232 ports on the MCPU faceplate.



Notice. Failure to comply with the following may result in property damage.

The RS232 port located on the MCPU faceplate uses Christie-proprietary protocol and is intended for Christie accessories or automation controllers only. For more information on the serial commands, see the [D4K-60 Serial API Commands Technical Reference \(P/N: 020-101258-XX\)](#).

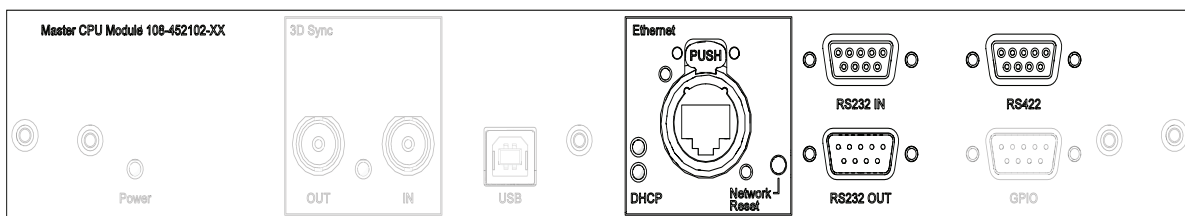

Set up Ethernet

Ethernet is setup to obtain an IP address automatically if a DHCP server is on the network. To modify IP settings, or manually enter an address.

1. On the touch panel controller, tap **Menu > Configuration > Ethernet Settings > Modify IP Settings**.
2. Set the network information for the projector:
 - To obtain information automatically from the network, tap **Automatic**.
 - To manually enter the network information, tap **Manual** and enter the **IP Address**, **Subnet Mask** and **Gateway** (optional).
3. Click **Ok**.

D4K3560 signal connectivity

Input configuration	Input format	Frame rate (Hz)	Interface	Cards	Cables	RGB/4:4:4			4:2:2	
						8-bit	10-bit	12-bit	2-bit	8-bit
Four-Port	4K, QHD	24, 25, 30, 48, 50, 60	DisplayPort 1.1a	2x TDPIC	4	X	X		X	X
Two-Port	4K, QHD	24, 25, 30, 48, 50, 60	DisplayPort 1.1a	2x TDPIC	2	X	X			
Four-Port	4K, QHD	24, 25, 30, 48, 50, 60	HDMI 1.4a	2x THIC	4	X	X	X	X	X
Four-Port	4K, QHD	24, 25, 30, 48, 50, 60	3G-SDI	2x3GIC	4				X	
Two-Port	4K, QHD	24, 25, 30, 48, 50, 60	DVI (Dual)	2xDDIC	2	X				
Four-Port	4K, QHD	24, 25, 30, 48, 50, 60	DVI (Single)	4x DDIC	4	X				
Two-Port	4K, QHD	24, 25, 30	DVI (Single)	2xDDIC	2	X				
One-Port	2K, HD	24, 25, 30, 48, 50, 60	DisplayPort 1.1a	1x TDPIC	1	X	X		X	X
One-Port	2K, HD	24, 25, 30, 48, 50, 60	HDMI 1.4a	1x THIC	1	X	X	X	X	X
One-Port	2K, HD	24, 25, 30	3G-SDI	1x 3GIC	1	X	X	X	X	X
One-Port	2K, HD	48, 50, 60	3G-SDI	1x 3GIC	1				X	
One-Port	2K, HD	24, 25, 30, 48, 50, 60	DVI (Single)	1x DDIC	1	X				

Operation

This section provides information and procedures for turning the projector on and off.

Projector LED status indicators

The table identifies the LED state colors and meaning.

LED	State	Description
Solid Green	On	Video electronics are on, the lamp is on.
Solid Yellow	Standby mode	Video electronics are off, lamp is off.
Solid Green, Yellow and Red	AC is on	MCPU board software has not started initialization.
Flashing Green	Warm up	Video electronics are initializing, lamp is striking and warming up.
Flashing Yellow	Cool down	Lamp is off, video electronics and lamp are cooling down.
Flashing Red	Alarm or warning preset	Problem with the projector must be addressed.
Flashing Green and Yellow	AC on to standby	MCPU board software has started initialization.

Turn the projector on



Warning! Failure to comply with the following could result in death or serious injury.

- Do not attempt to turn the projector on if the AC supply is not within the specified voltage range.

1. Set the all the breaker switches on the lamp power supply to their on positions.
2. Set the breaker switch on the projector baseplate to the on position.
3. When the projector reaches standby, on the touch panel controller, tap **Home > Power**.

LED expected behavior on power up

The following table shows the expected behavior of the projector LED and the MCPU board power LED on power up:

Action/Event	Projector LEDs	MCPU Board Power LED
Applying AC power to the projector head	Solid red Solid green Solid yellow	Yellow
Within the first second	Solid red Solid green Solid yellow	Blinking green
At approximately 30 seconds	Off red Blinking yellow Blinking green	Blinking green
At approximately 50 seconds	Off/blinking red Solid yellow Off green	Solid green

At approximately one minute and 15 seconds, the TPC indicates that it is connected and shows the home page.

Turn the projector off

1. On the touch panel controller, tap the **Home** tab.
2. Tap **Power**.



When powering off in preparation for inspection or maintenance, always disconnect from AC, set the projector breaker and lamp power supply breakers to the off positions.

Corporate offices

USA – Cypress
ph: 714-236-8610

Canada – Kitchener
ph: 519-744-8005

Consultant offices

Italy
ph: +39 (0) 2 9902 1161

Worldwide offices

Australia
ph: +61 (0) 7 3624 4888

Brazil
ph: +55 (11) 2548 4753

China (Beijing)
ph: +86 10 6561 0240

China (Shanghai)
ph: +86 21 6278 7708

Eastern Europe and
Russian Federation
ph: +36 (0) 1 47 48 100

France
ph: +33 (0) 1 41 21 44 04

Germany
ph: +49 2161 664540

India
ph: +91 (080) 6708 9999

Japan (Tokyo)
ph: 81 3 3599 7481

Korea (Seoul)
ph: +82 2 702 1601

Republic of South Africa
ph: +27 (0)11 510 0094

Singapore
ph: +65 6877-8737

Spain
ph: + 34 91 633 9990

United Arab Emirates
ph: +971 4 3206688

United Kingdom
ph: +44 (0) 118 977 8000