

# E Series Adapter Plate Installation Instruction Sheet

---

**⚠ WARNING** SAFETY CRITICAL ASSEMBLY! These work instructions must only be performed by an accredited service technician.

## INTRODUCTION

When stacking E Series projectors, an adapter plate is required to install the E Series unit into the stacking frame. These instructions will guide you through the process of installing the adapter plate onto the base of the projector.

## KIT REQUIRED

133-107109-XX includes:

- Adapter Plate Stacker (*011-104115-XX*)
- Flathead Screw M6x25 (*012-101578-XX*)
- Spring Lock Washer (*012-100494-XX*)
- Socket Head Cap Screw M8x14 (*012-101102-XX*)

## TOOLS REQUIRED

Allen Keys: 4 mm, 6 mm

Torque Wrench with 4 mm and 6 mm Allen heads

## INSTRUCTIONS

1. Place the projector top-side down, on a clean and flat surface.
2. Line up the adapter plate mounting holes with the mounting holes on the baseplate.
3. Secure the adapter plate with 4 M6x25 flathead screws. Torque to 41 in-lb.

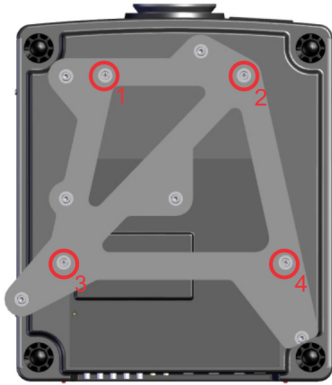

4. Mount the projector to the stacking frame.
5. Secure the frame with 6 M8x25 socket head cap screws with lock washers. Torque to 382 in-lb.

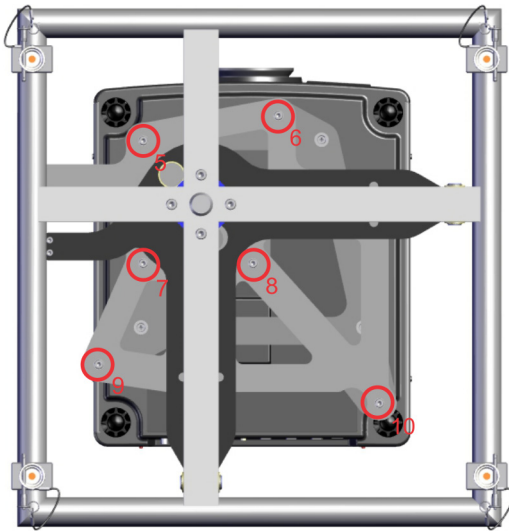

**WARNING!** Make sure all screws and bolts are fastened properly. Failure to do so may result in serious injury or death.