

REV	DESCRIPTION OF CHANGE	BY	REV DATE
01	INITIAL RELEASE	SI	5/26/2009
02	UPDATE NOTES/CORRECT AMBIENT TEMP.	SI	11/4/2009
03	ADDED EXHAUST DUCT & FRED FRAME ACCESSORIES	LP	4/12/2010

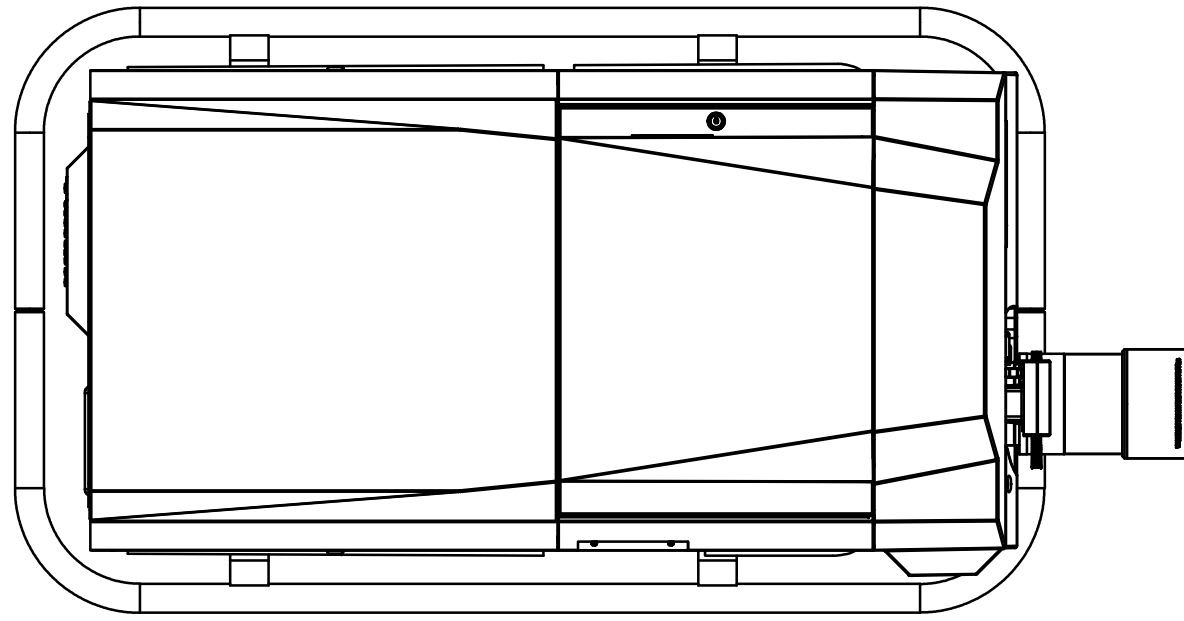

PROJECTOR SHOWN WITH 1.25-1.45:1 ZOOM LENS

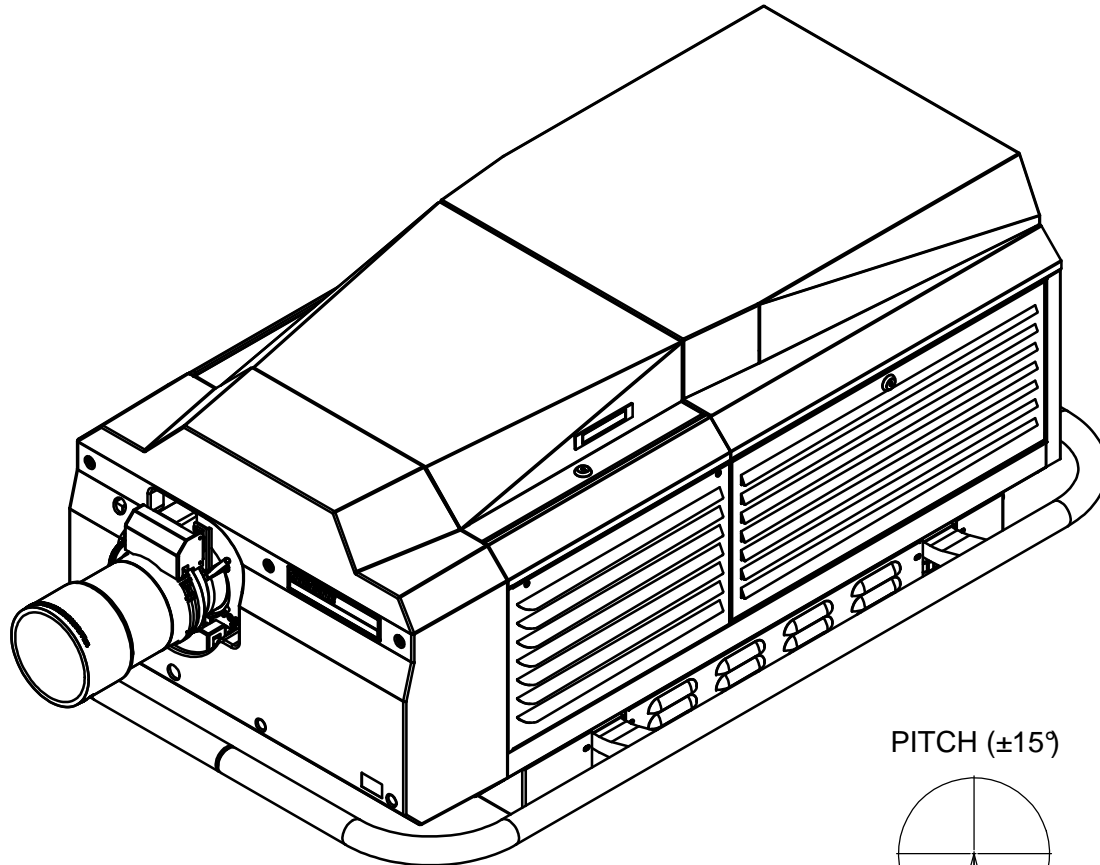

ROLL (±15°)

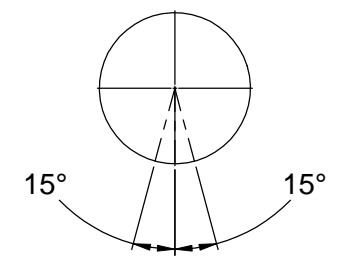

PITCH (±15°)

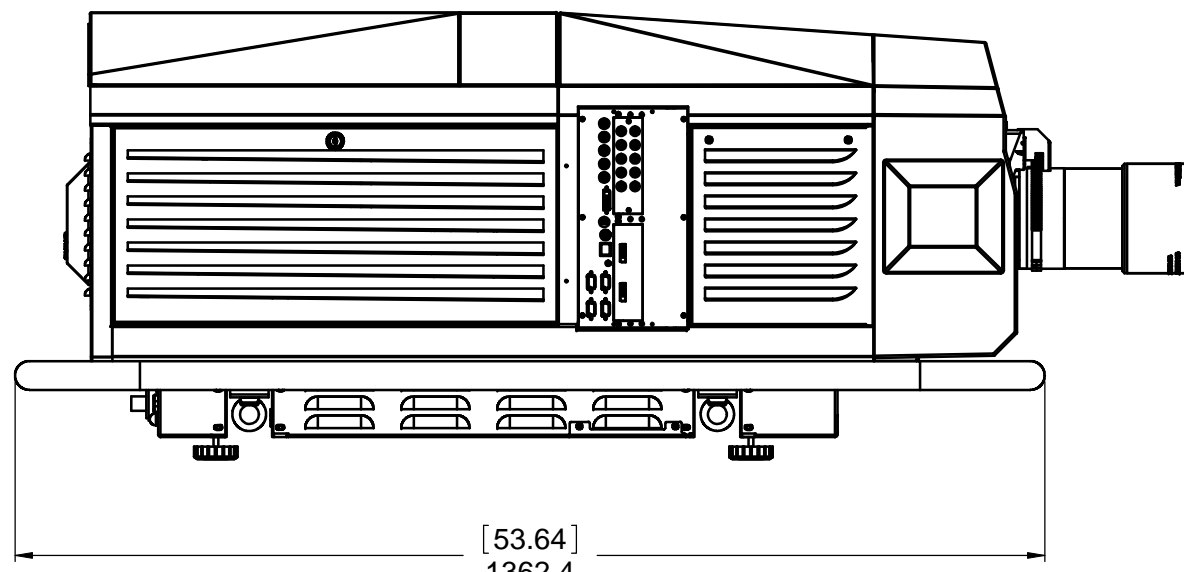
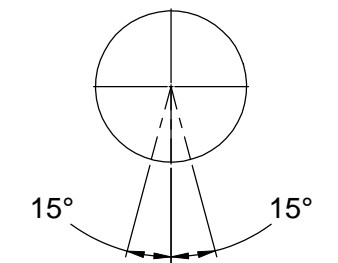

[53.64]
1362.4

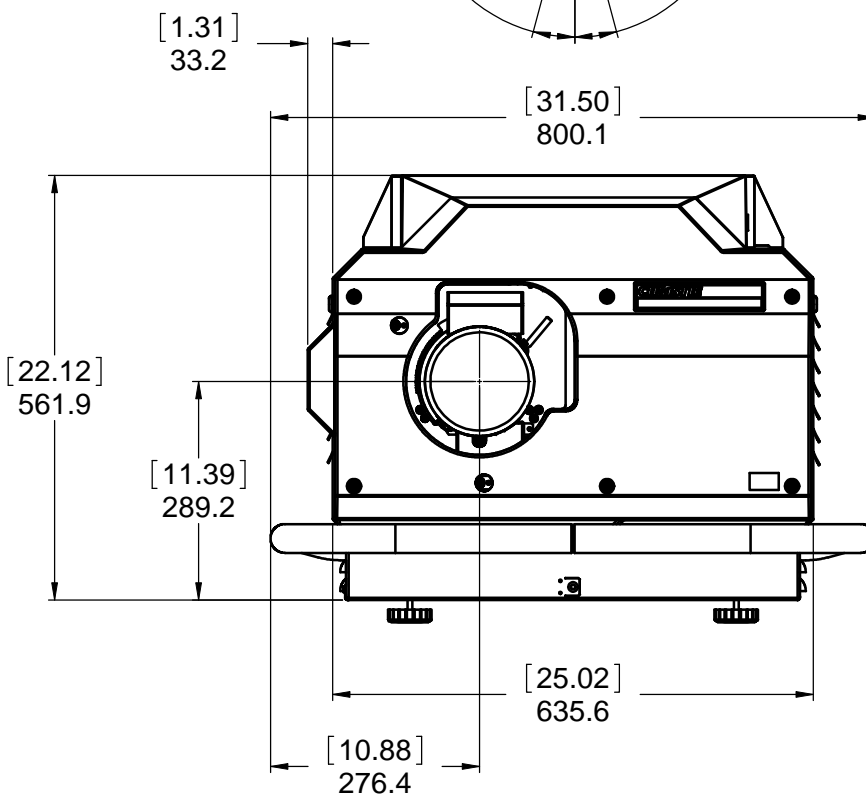

[1.31]
33.2

[31.50]
800.1

[22.12]
561.9

[11.39]
289.2

[25.02]
635.6

[10.88]
276.4

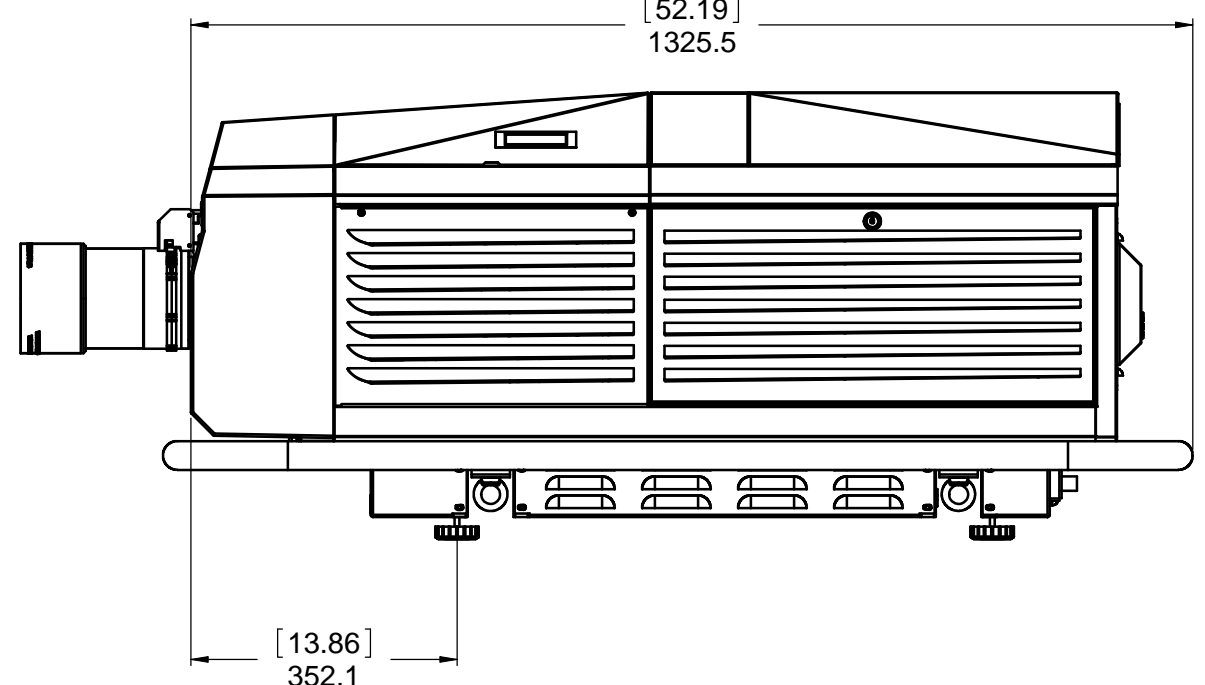

[52.19]
1325.5

[13.86]
352.1

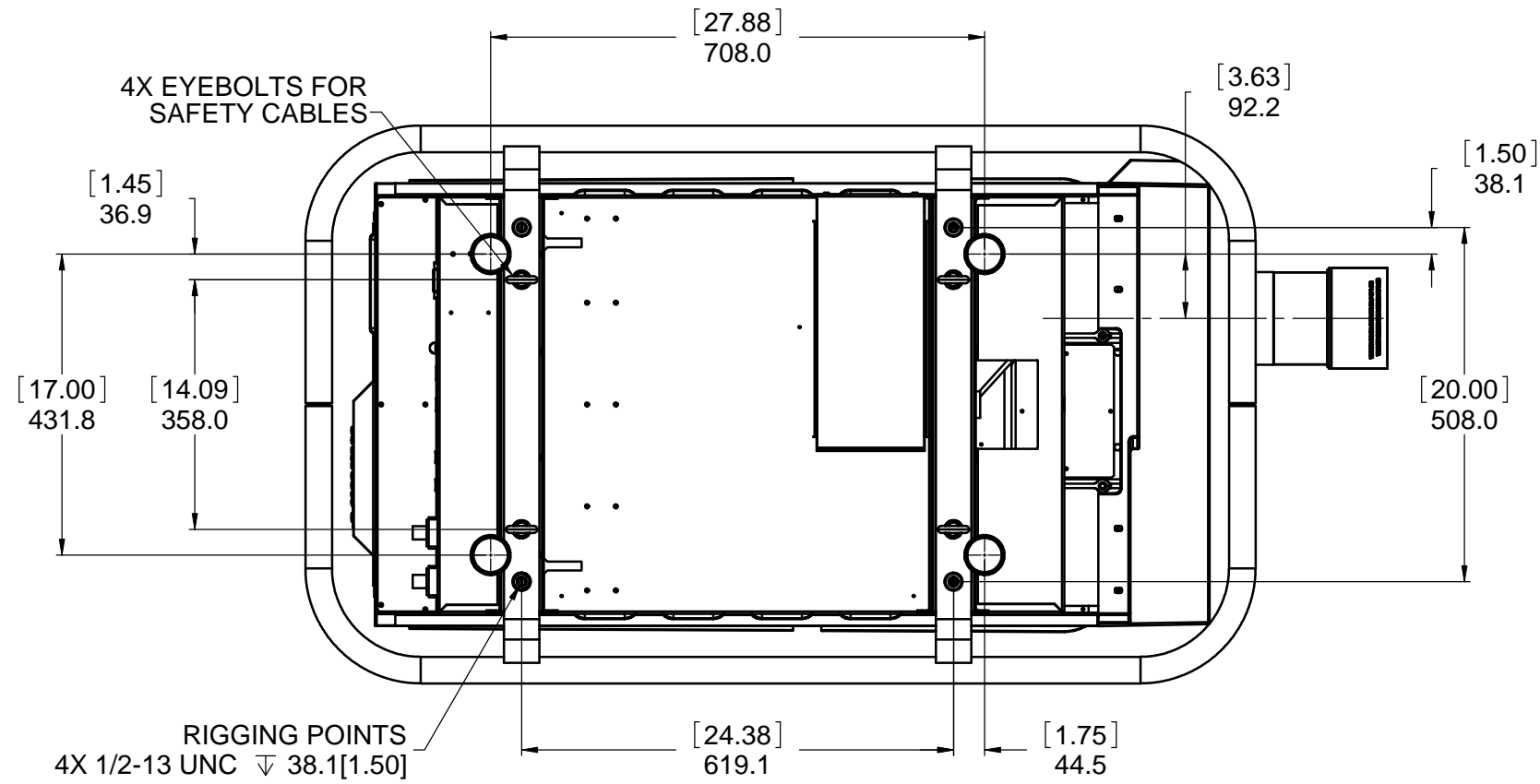

4X EYEBOLTS FOR SAFETY CABLES

[27.88]
708.0

[3.63]
92.2

[1.50]
38.1

[1.45]
36.9

[17.00]
431.8

[14.09]
358.0

[20.00]
508.0

RIGGING POINTS
4X 1/2-13 UNC ∇ 38.1[1.50]

[24.38]
619.1

[1.75]
44.5

GENERAL NOTES:

WEIGHTS:

PROJECTOR HEAD MASS: INSTALLED WEIGHT= 197.8kg (435lbs) NO LENS
SHIPPING WEIGHT= 209.1kg (460lbs) NO LENS
BALLAST MASS: INSTALLED WEIGHT= 50kg (110lbs)
SHIPPING WEIGHT= 65.8kg (145lbs)

FRED FRAME™: INSTALLED WEIGHT= 50kg (110lbs)
SHIPPING WEIGHT= 64kg (141lbs)

AMBIENT AIR TEMPERATURE: 35°C (149°F) MAX. OPERATING

POWER REQUIREMENTS:

PROJECTOR HEAD - SINGLE PHASE 200-240V AC, 3A max.
MAX. POWER CONSUMPTION: 600W electrical to the head

BALLAST - 3 PHASE 200-230V AC, 24A (N. AMERICA / JAPAN)
3 PHASE 380-415V AC, 16A (EUROPE)
POWER CONSUMPTION: approx. 8.0kW

SYSTEM- MAX. POWER CONSUMPTION: 8.6kW

THERMAL DISSIPATION:

When using a Roadie in enclosed environments, the thermal dissipation needs to be properly planned for in order to prevent thermal shutdowns and other interlock nuisance trips

PROJECTOR HEAD - The Head dissipates 1,000W of heat from the front compartment (3,415 BTU/hr) and 6,600W of heat from the rear exhaust (22,540 BTU/hr)

BALLAST -The Ballast dissipates 1,000W of heat from the electronics (3,415 BTU/hr)

SYSTEM- 29,370 BTU/hr MAX.

TILT ANGLE: ±15° MAX. PITCH/ROLL

UNITS: INCHES / MILLIMETRES	CAD MAINTAINED DATA CHANGES SHALL BE INCORPORATED ELECTRONICALLY	CHRISTIE DIGITAL SYSTEMS USA, INC. / CHRISTIE DIGITAL SYSTEMS CANADA, INC.
UNLESS OTHERWISE SPECIFIED INTERFER DIMENSIONS AND TOLERANCES PER ASME Y14.5M-1994	DATE: 03/01/2007	
TOLERANCES APPLY AS SHOWN BELOW	PROPRIETARY	PART DESCRIPTION
DECIMAL PLACES: .XXX ± 0.03, .XX ± 0.13, .X ± 0.50	NOT TO BE DISCLOSED OR REPRODUCED IN ANY MANNER WITHOUT THE EXPRESS WRITTEN PERMISSION OF CHRISTIE	ROADIE HD+35K LINE DRAWING
ANGULAR DIMENSIONS: 30° ± 0.5°, 30.0° ± 0.5°	THIRD ANGLE PROJECTION	TAXI NUMBER: 020-100371-01
	SCALE: 1:5	WEIGHT: - LBS (- KG)
		SHEET 1 OF 6

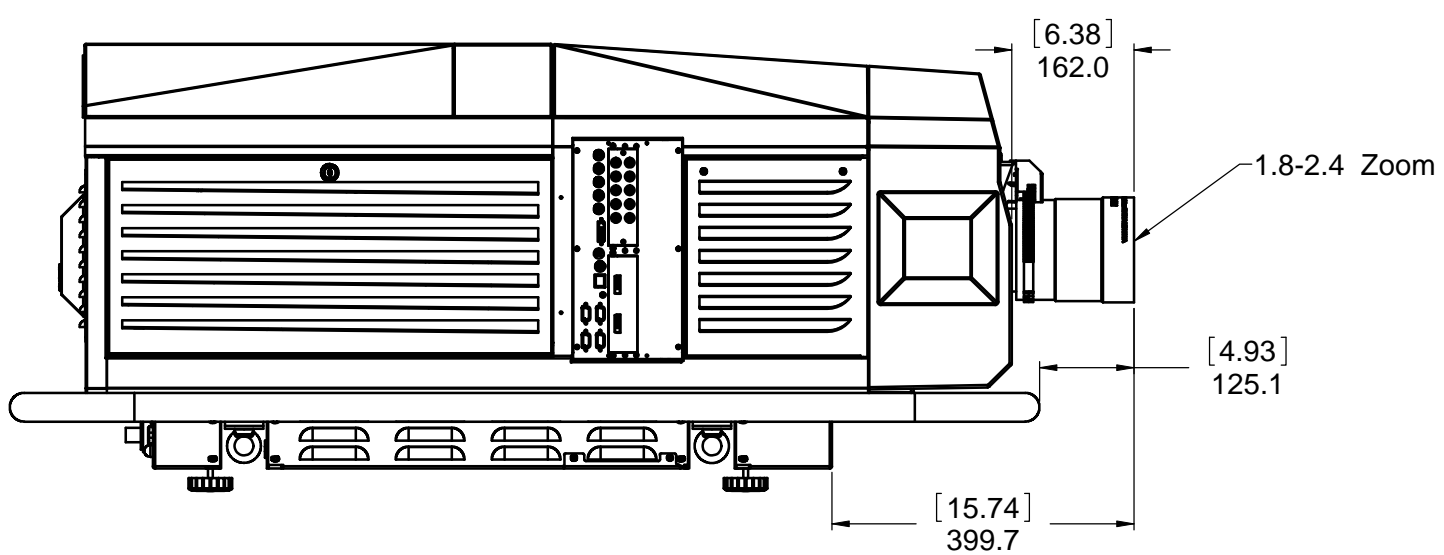
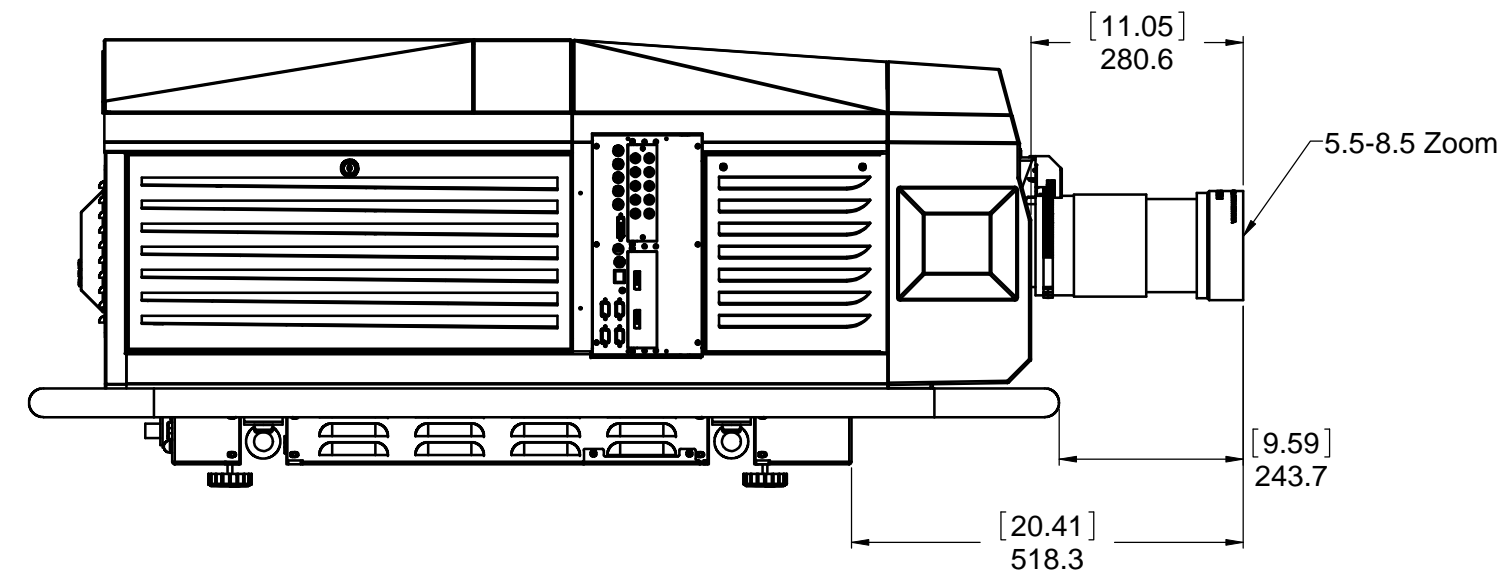
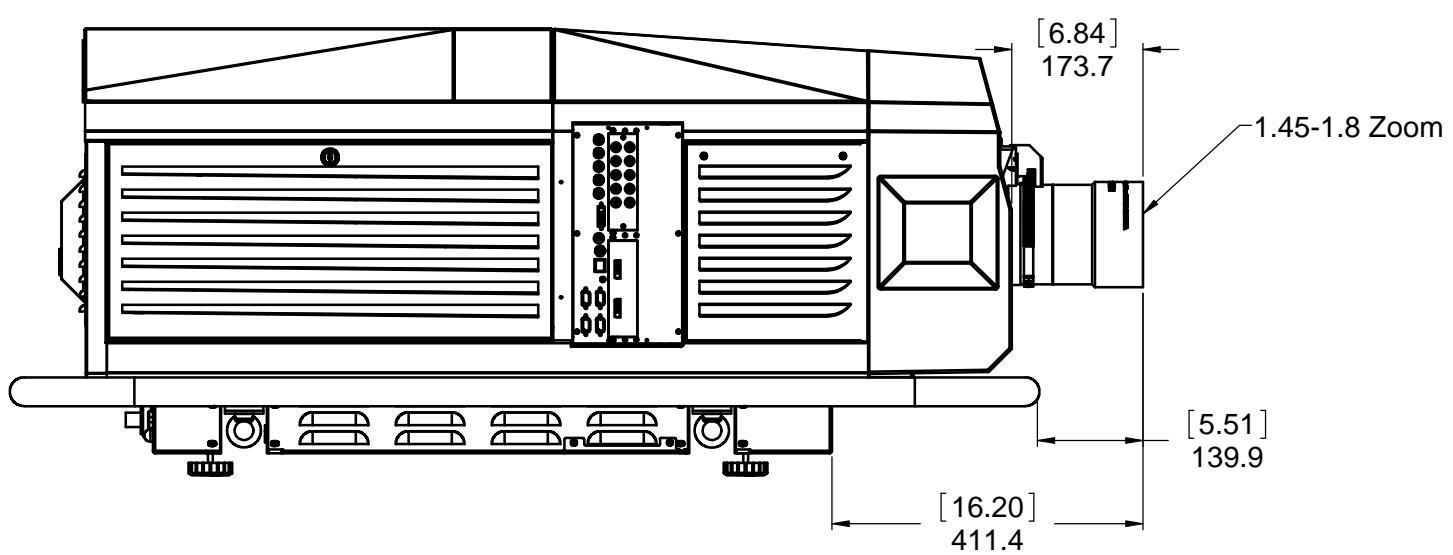
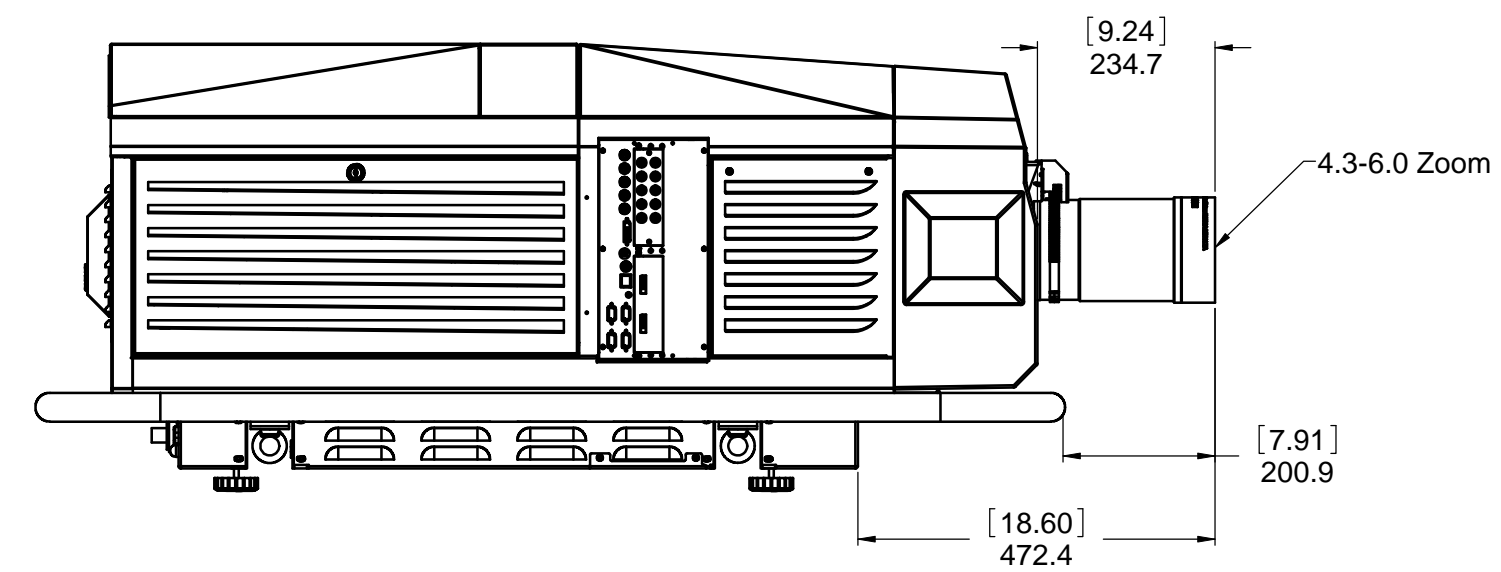
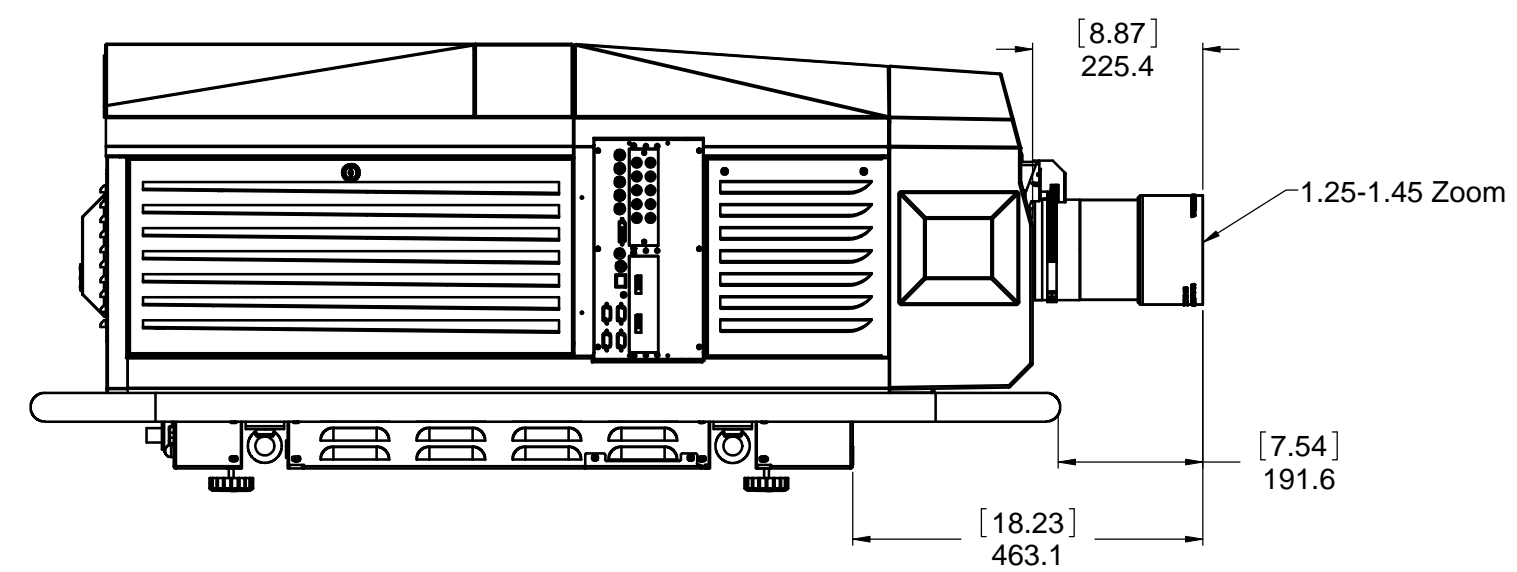
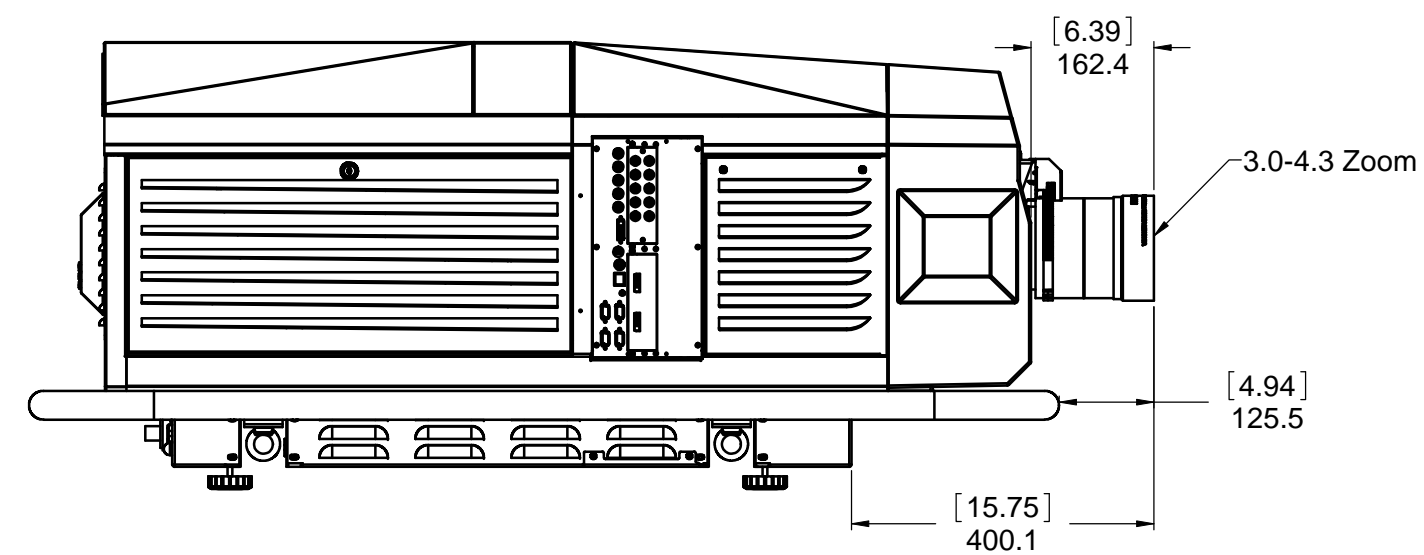
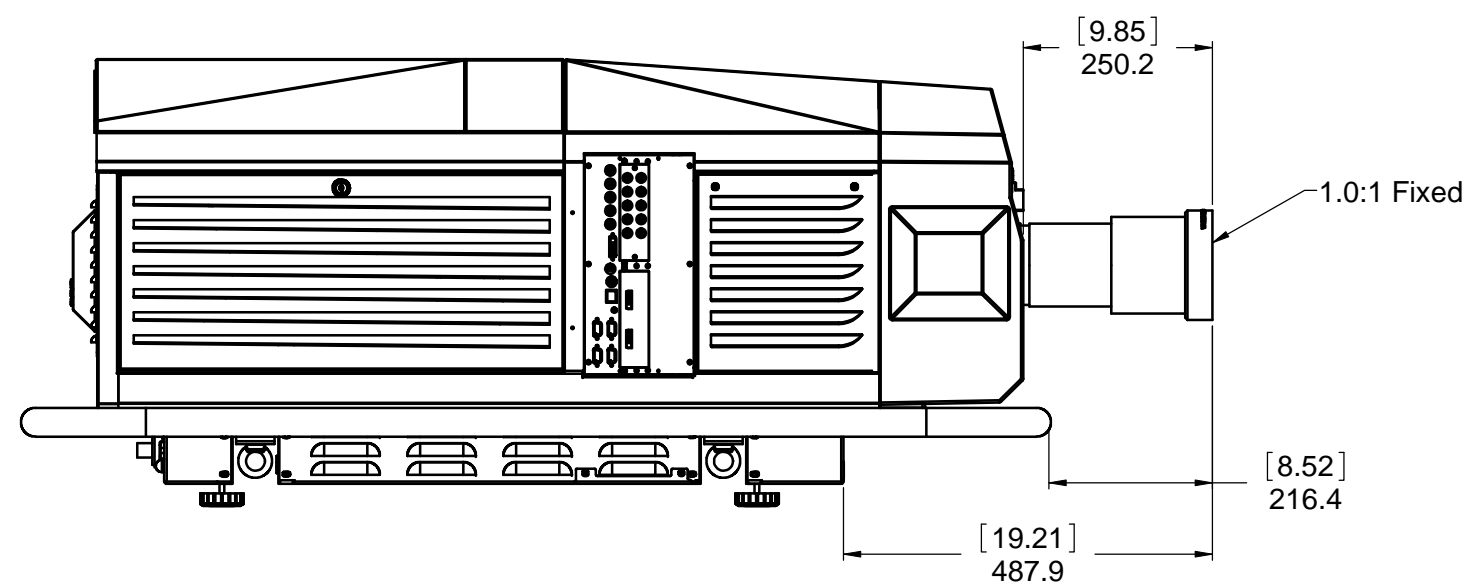
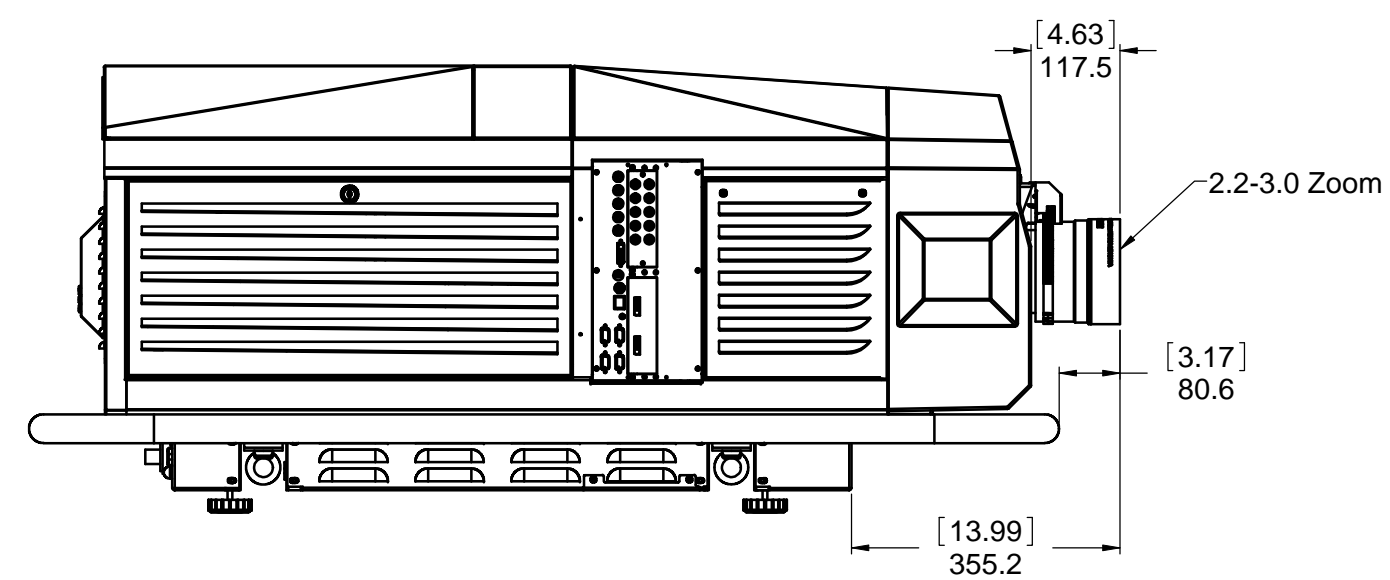
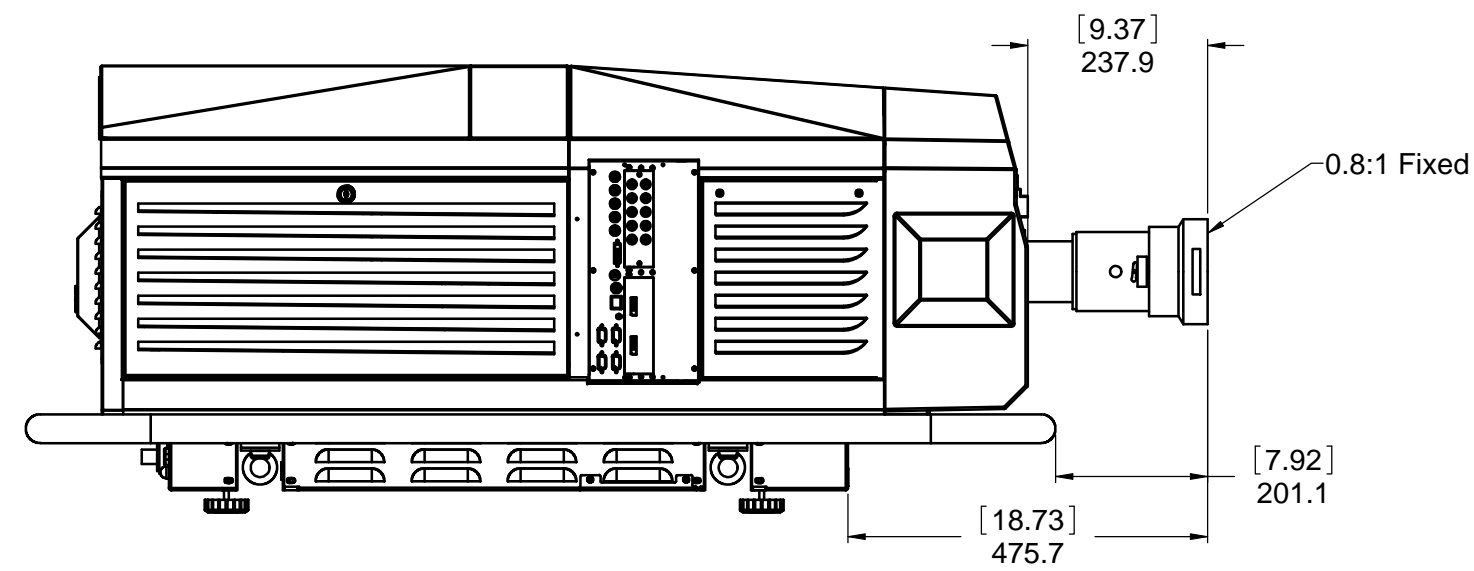

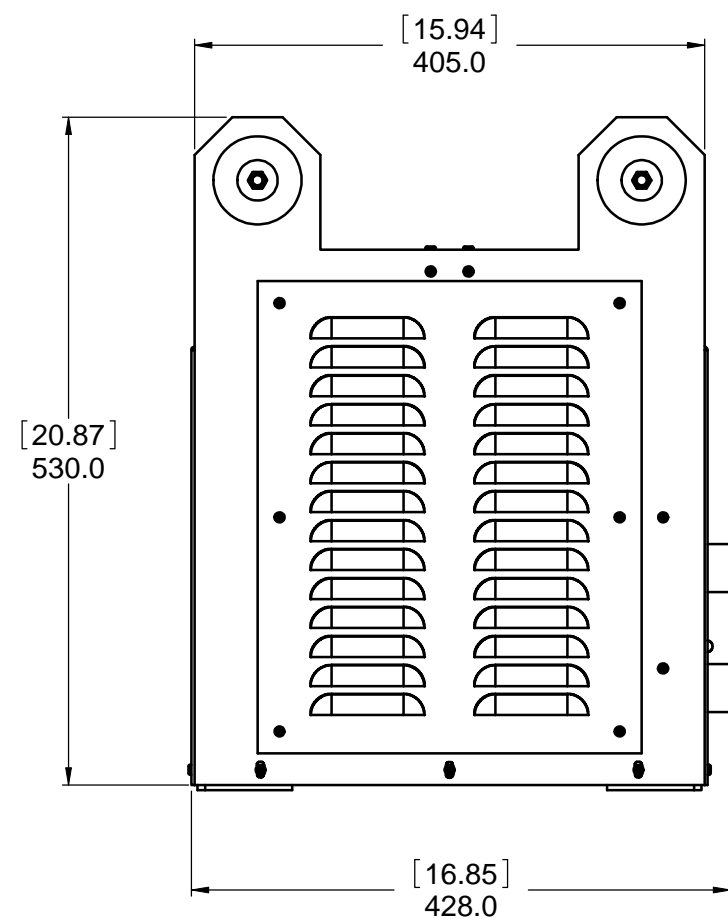

7KW SWITCHING BALLAST
38-814001-51

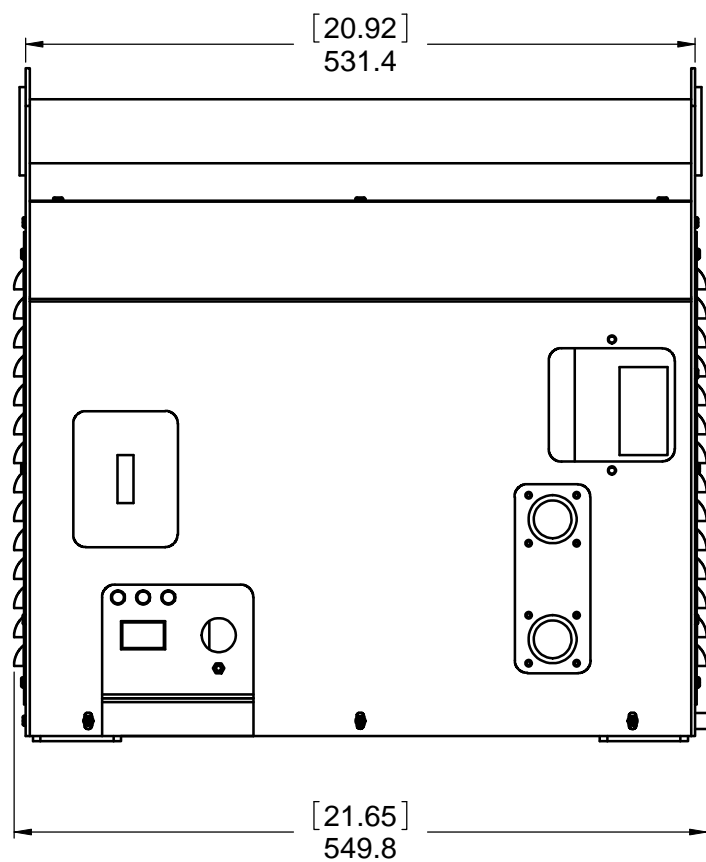

WEIGHT: 66KG (145 LB)

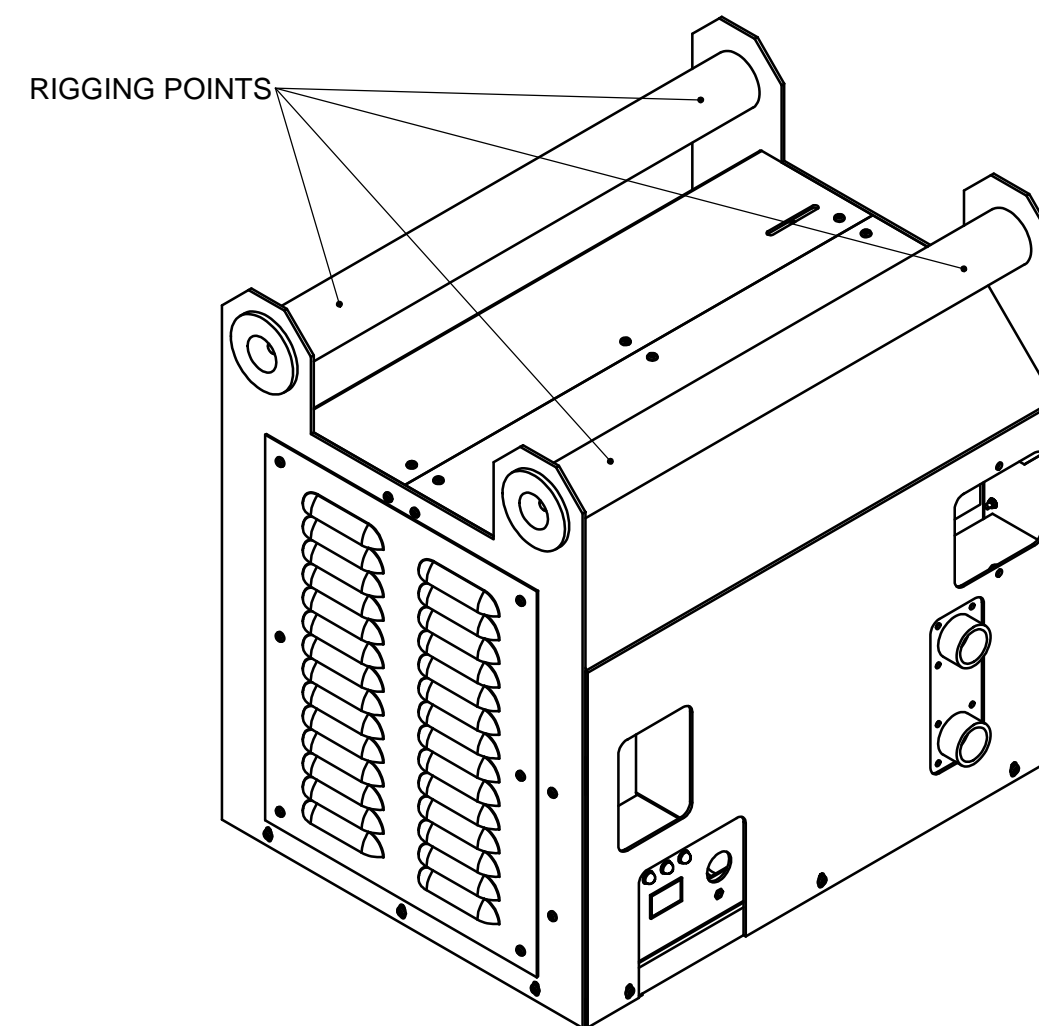

0.8:1 FIXED LENS
113-104106-XX WEIGHT: 7KG (15.43 LB)

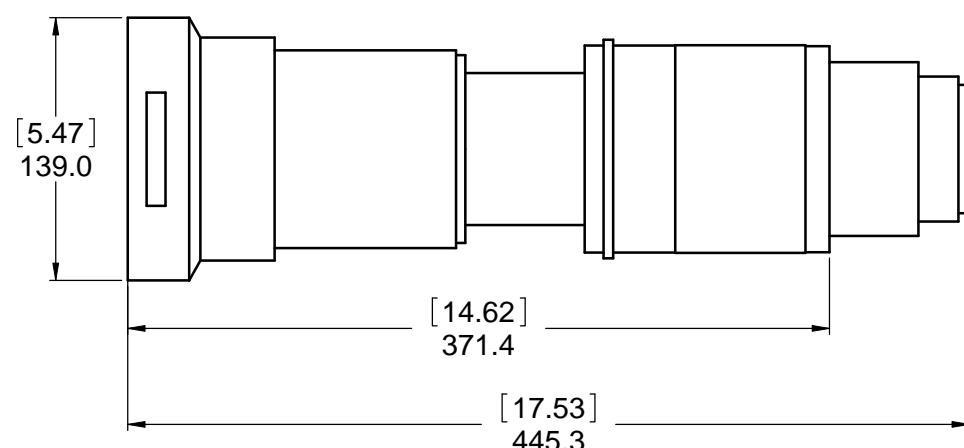

1.45-1.8:1 ZOOM LENS
38-809074-XX WEIGHT: 7KG (15.43 LB)

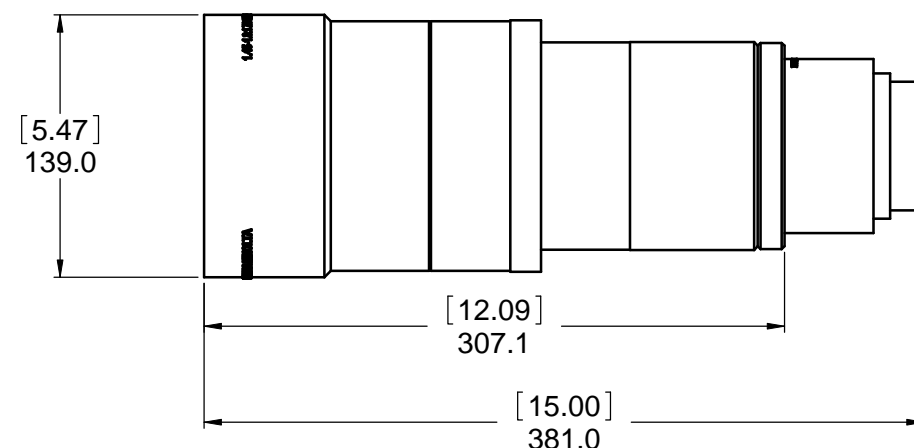

3.0-4.3:1 ZOOM LENS
38-809077-XX WEIGHT: 7KG (15.43 LB)

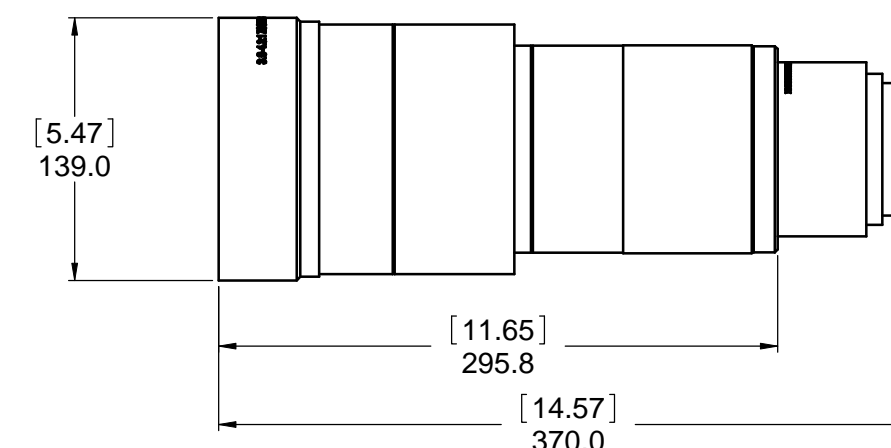

1.0:1 FIXED LENS
38-809071-XX WEIGHT: 7KG (15.43 LB)

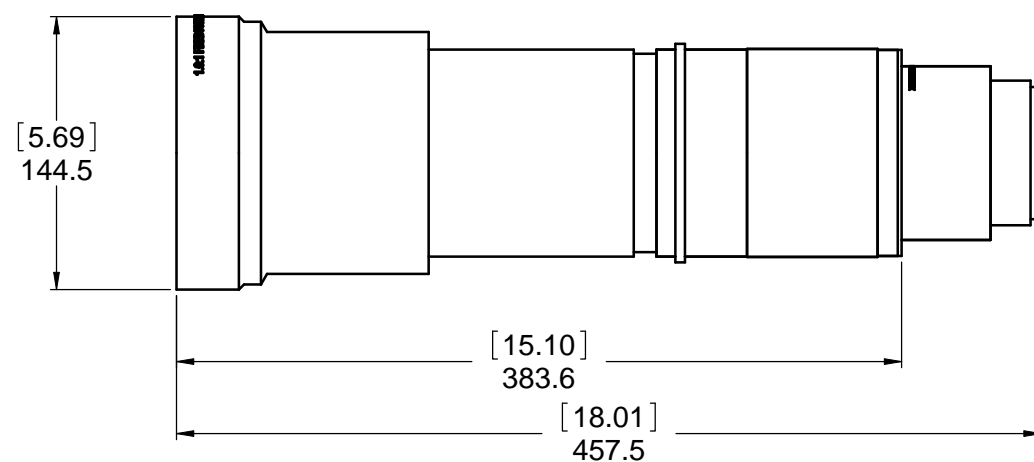

1.8-2.4:1 ZOOM LENS
38-809075-XX WEIGHT: 7KG (15.43 LB)

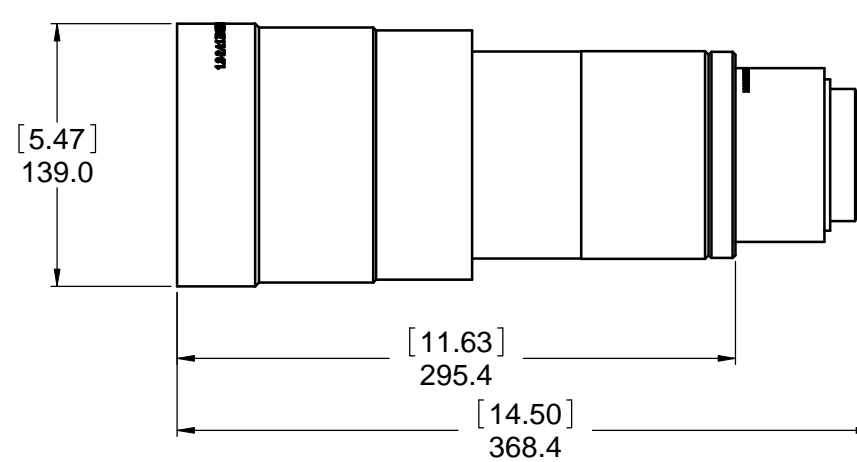

4.3-6.0:1 ZOOM LENS
38-809072-XX WEIGHT: 8KG (17.64 LB)

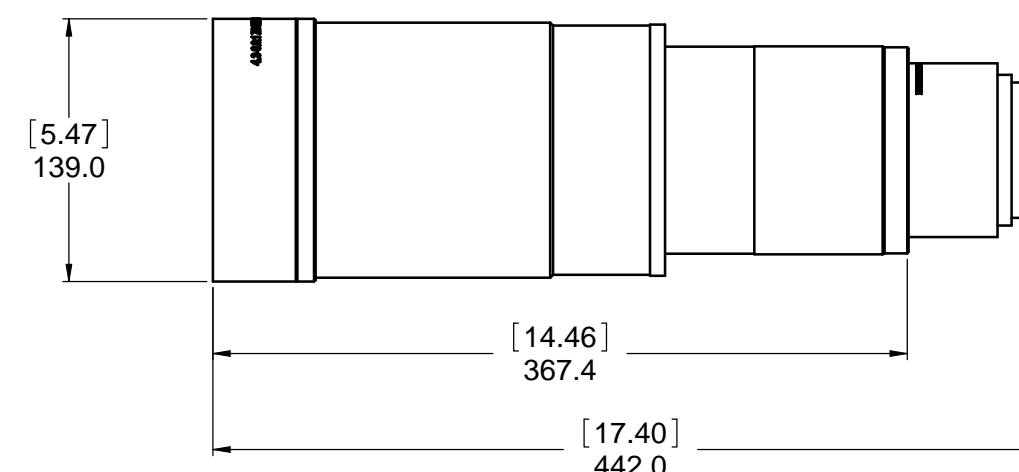

1.25-1.45:1 ZOOM LENS
38-809073-XX1 WEIGHT: 8KG (17.64 LB)

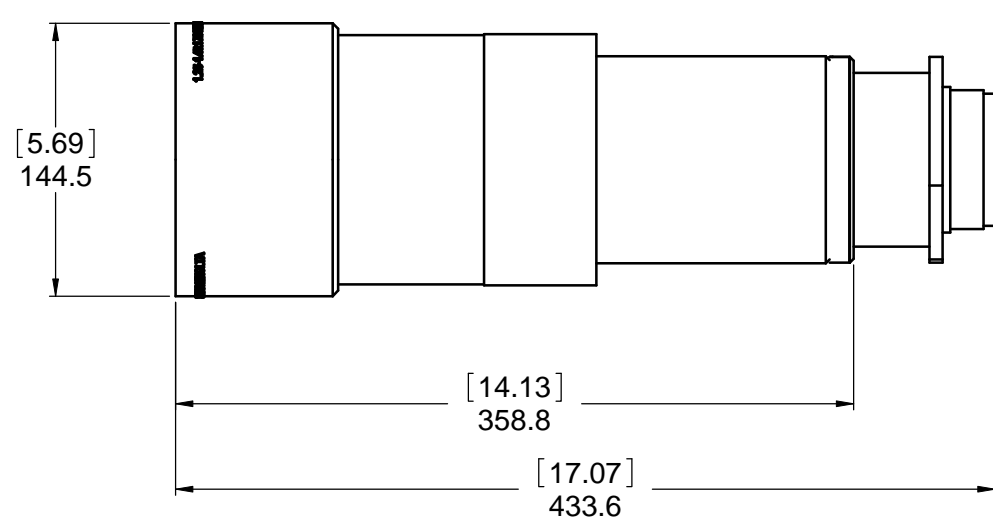

2.2-3.0:1 ZOOM LENS
38-809076-XX WEIGHT: 7KG (15.43 LB)

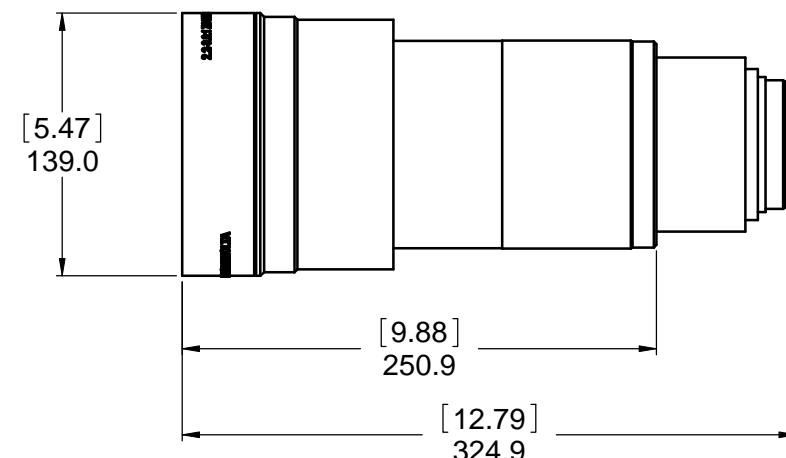

5.5-8.5:1 ZOOM LENS
38-809078-XX WEIGHT: 9KG (19.84 LB)

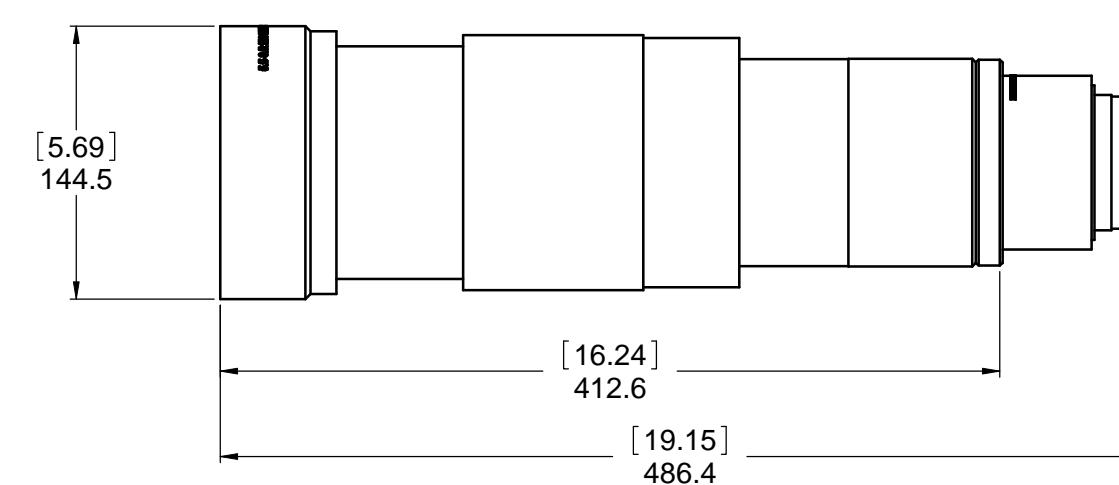

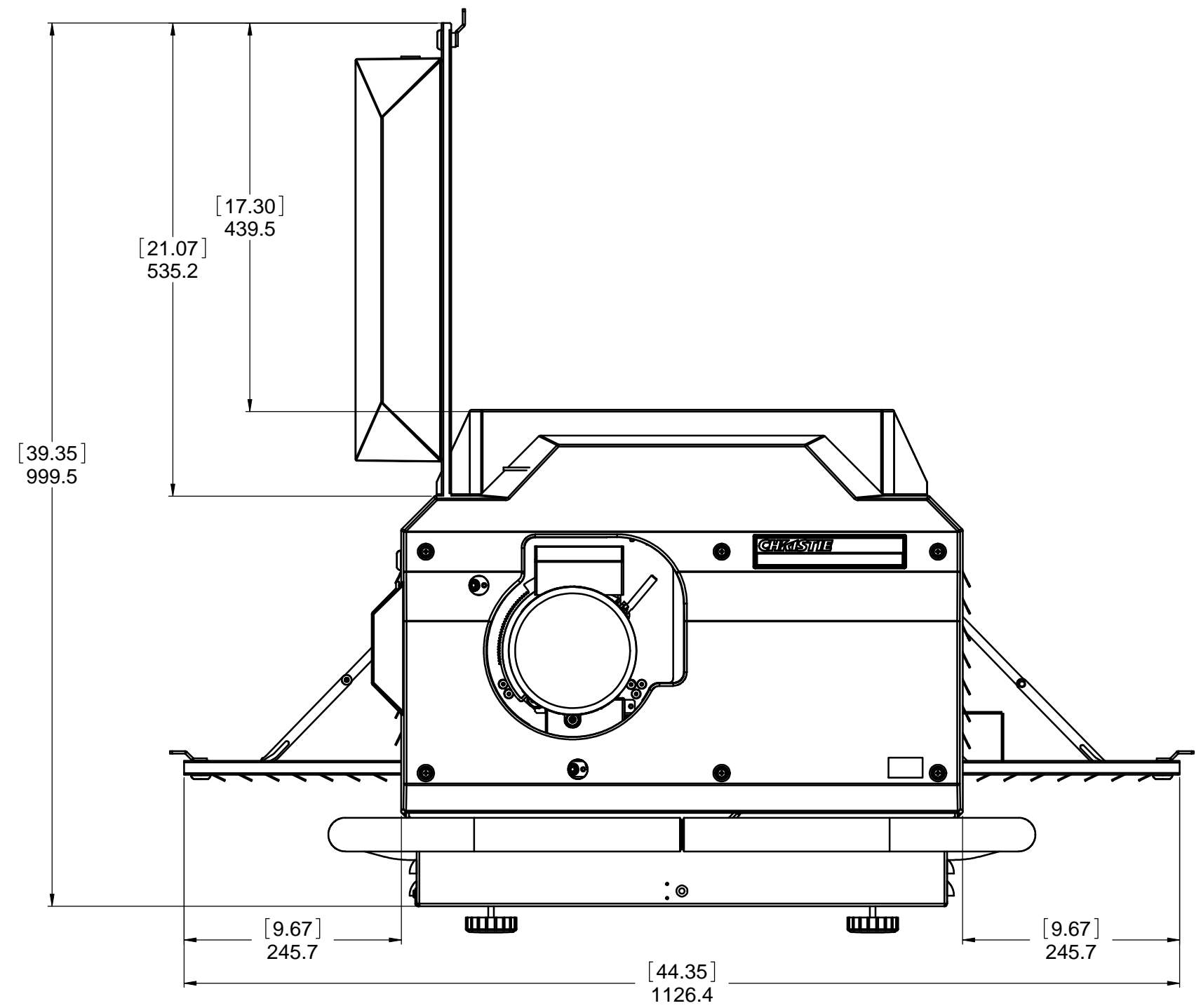
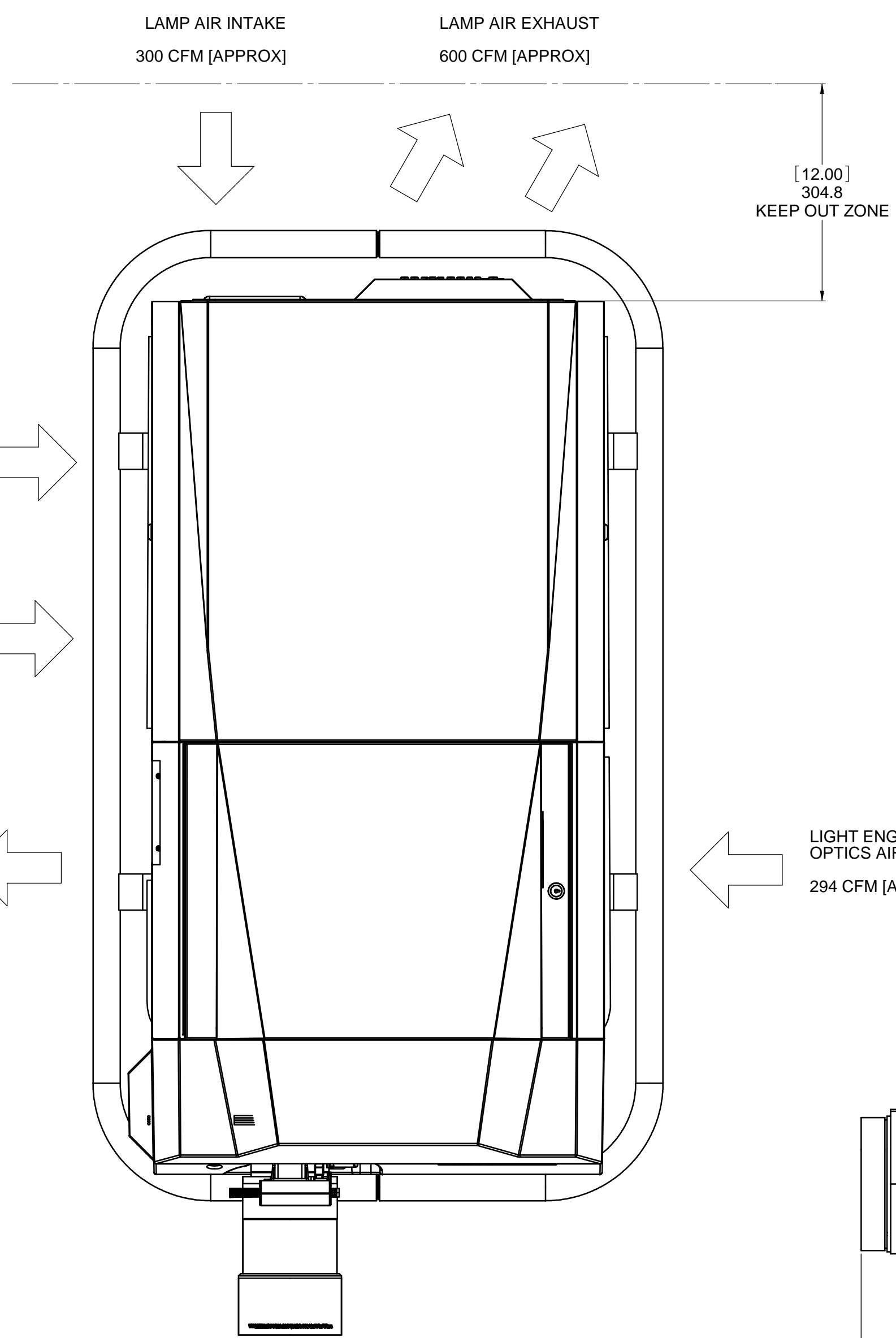

NOTE: SHOWN WITH DOORS OPEN

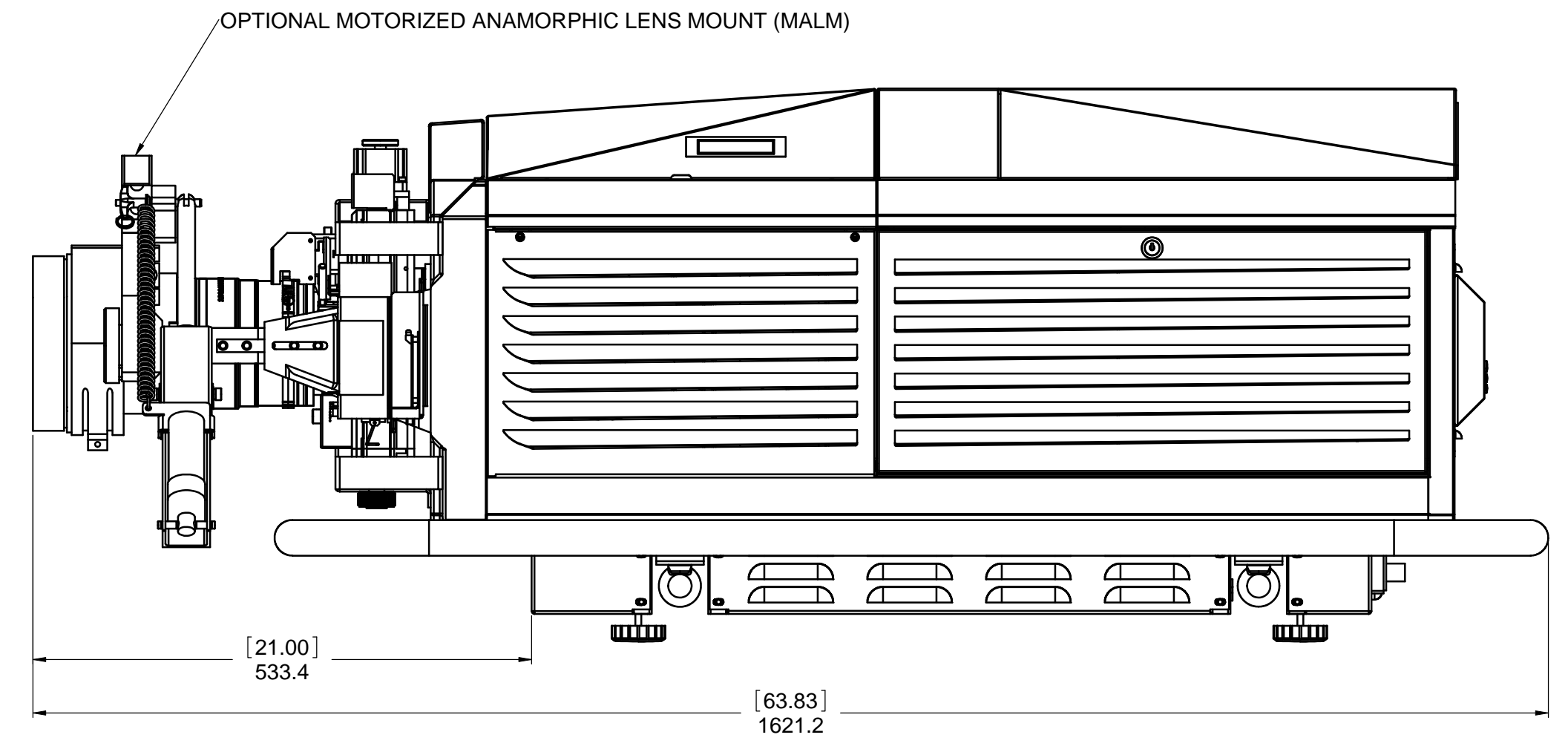
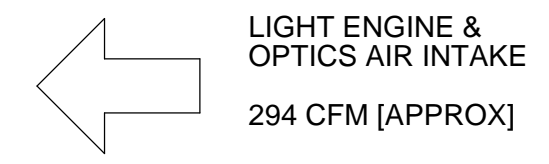

NOTE: SHOWN ABOVE WITH OPTIONAL MALM (FRONT COVER
MUST BE REMOVED TO PERMIT MOUNTING)

THE ANAMORPHIC LENS MOUNT WORKS WITH THE FOLLOWING ZOOM
LENSES: 1.45-1.8:1, 1.8-2.4:1, 2.2-3.0:1 AND 3.0-4.3:1

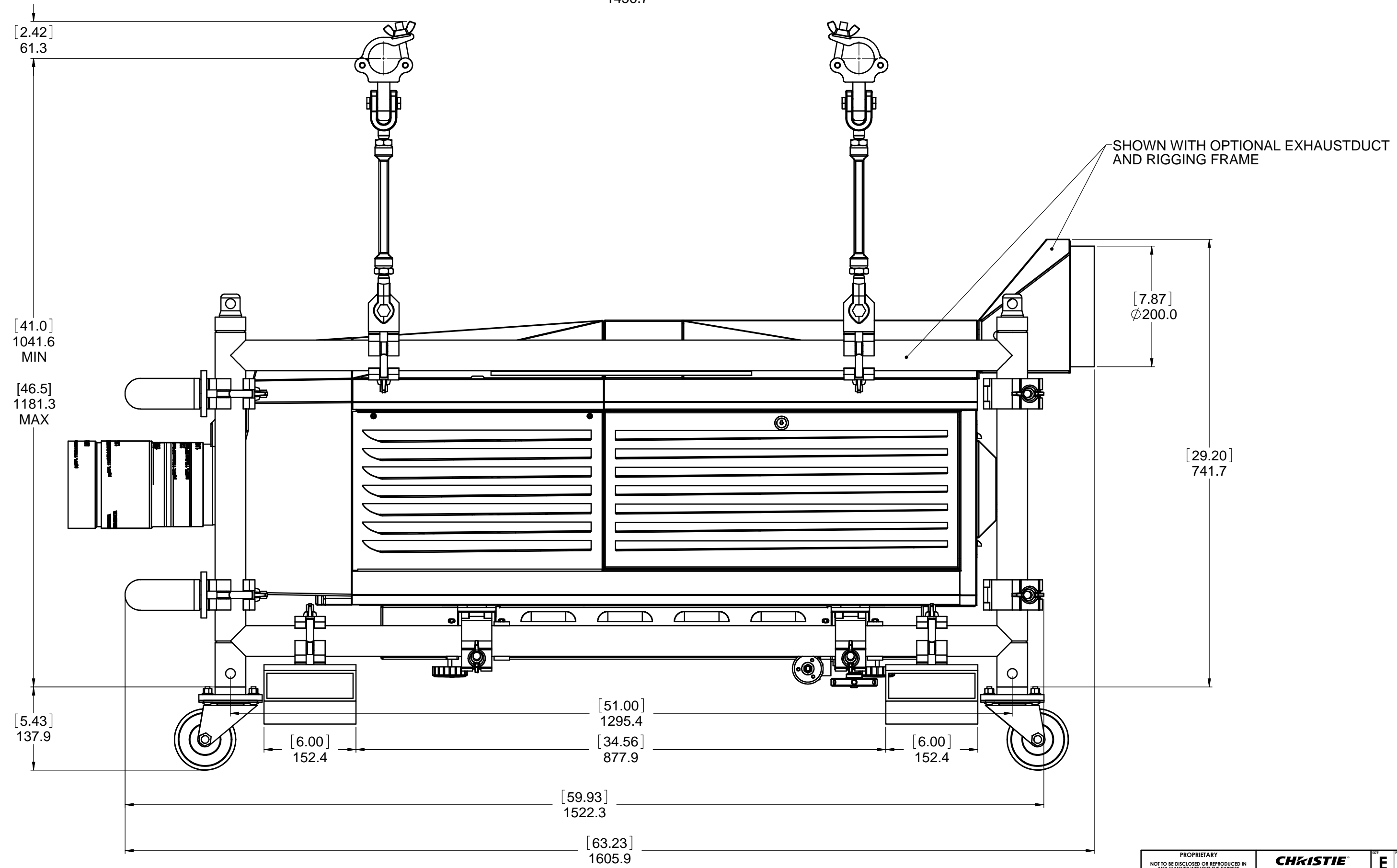
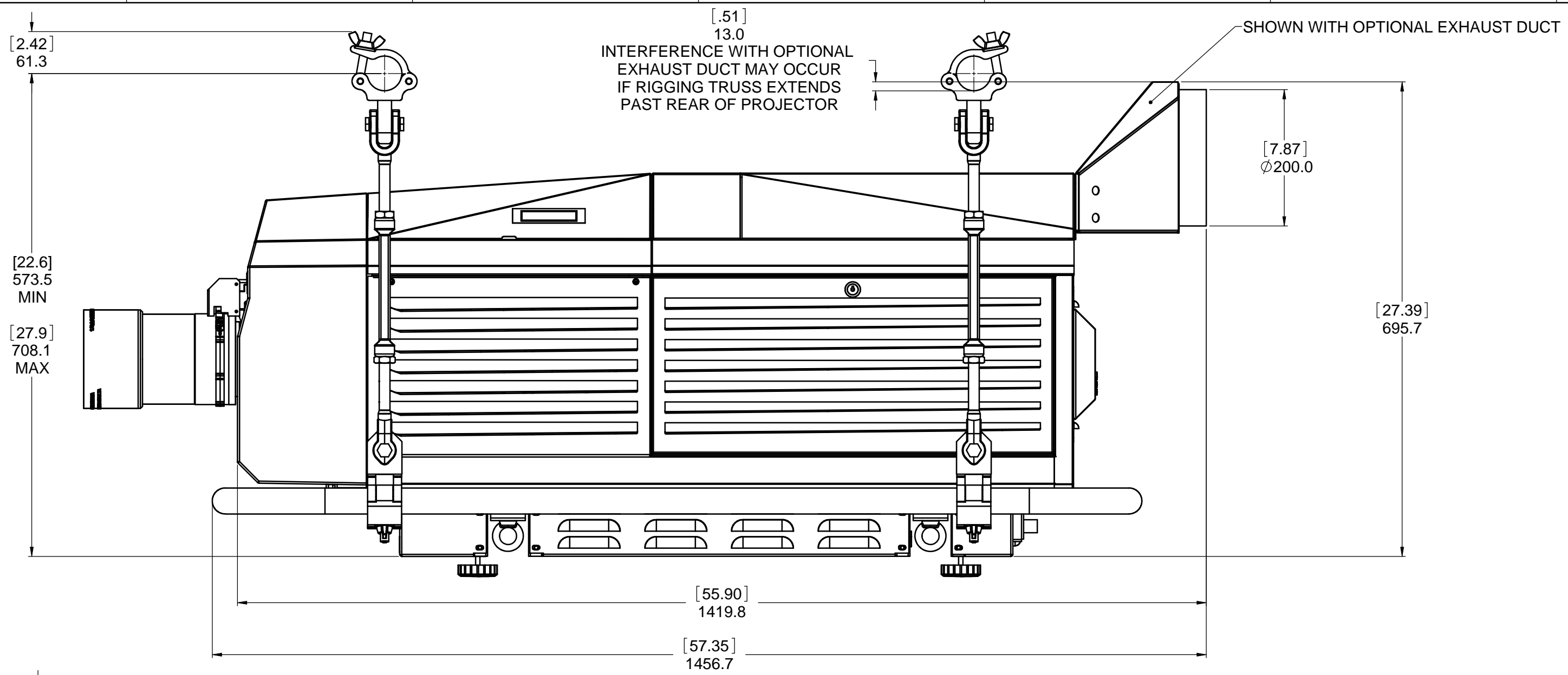

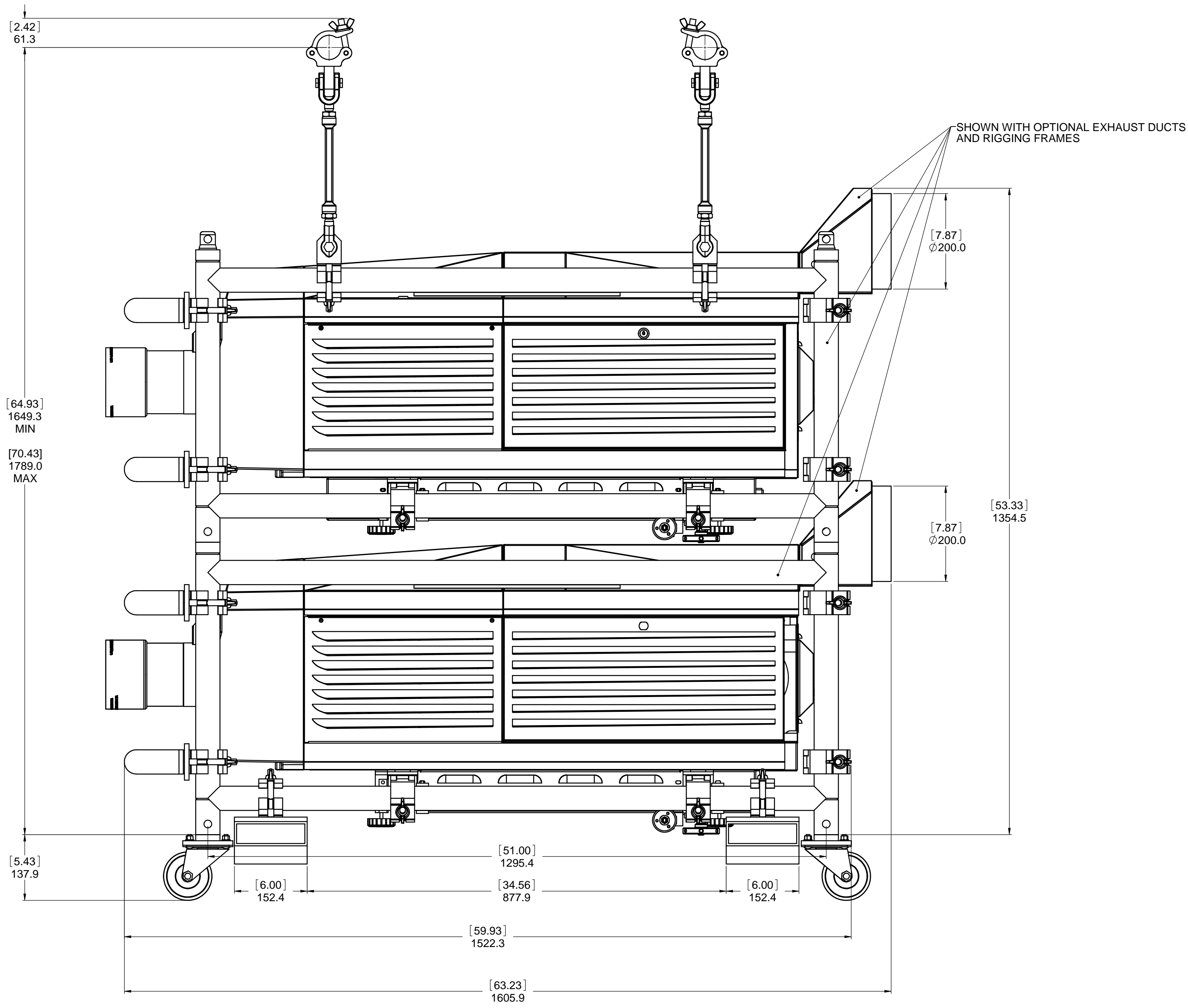

SHOWN WITH OPTIONAL EXHAUST DUCTS AND RIGGING FRAMES

[2.42]
61.3

[64.93]
1649.3
MIN

[70.43]
1789.0
MAX

[7.87]
Ø200.0

[7.87]
Ø200.0

[53.33]
1354.5

[5.43]
137.9

[6.00]
152.4

[51.00]
1295.4

[34.56]
877.9

[6.00]
152.4

[59.93]
1522.3

[63.23]
1605.9