

- NOTES:**
1. DIMENSIONS ARE IN MILLIMETRES [INCHES IN BRACKETS]
 2. DRAWINGS ARE FOR REFERENCE ONLY. ALL DIMENSIONS ARE REFERENCE ONLY. NOMINAL DIMENSIONS SHOWN.
 3. SPECIFICATIONS MAY CHANGE WITHOUT NOTICE
 4. PRODUCT DETAILS MAY VARY FROM DRAWING
 5. ASSEMBLY: CUBE, SCREEN AND PEDESTAL SHOWN FOR REFERENCE
 6. MAXIMUM STACKING HEIGHT: FOUR CUBES WITH SCREENS ON TOP OF ONE PEDESTAL
 7. UNLESS OTHERWISE SPECIFIED ALL DIMENSIONS APPLY TO ALL PART NUMBERS AS LISTED
 8. THE CUBE CAN BE INSTALLED AGAINST A BACK WALL, THE MINIMUM DISTANCE BETWEEN THE REAR PANEL AND BACK WALL SHOULD BE 110MM.
 9. THE MAXIMUM STACKING LIMITATION IS 3 CUBES HIGH IN A MINIMUM 2 COLUMN DISPLAY WALL.
 10. THE PEDESTAL INCLUDES A REMOVABLE FRONT PANEL TO ALLOW FOR INSTALLATION WHEN POSITIONING THE CUBES AGAINST A BACK WALL.
 11. EVERY COLUMN OF CUBES REQUIRES 1 TIE BACK. EACH TIE BACK MUST BE CAPABLE OF WITHSTANDING A PULLOUT FORCE OF 500LBS
 12. EACH COLUMN OF CUBES REQUIRES 4 ANCHOR BOLTS. EACH ANCHOR BOLT MUST BE CAPABLE OF WITHSTANDING A PULLOUT FORCE OF 500LBS.

REVISION HISTORY OF: 020-000747-01			
REV	DESCRIPTION OF CHANGE	BY	DATE UPDATED
01	INITIAL RELEASE	SX	05/16/2014

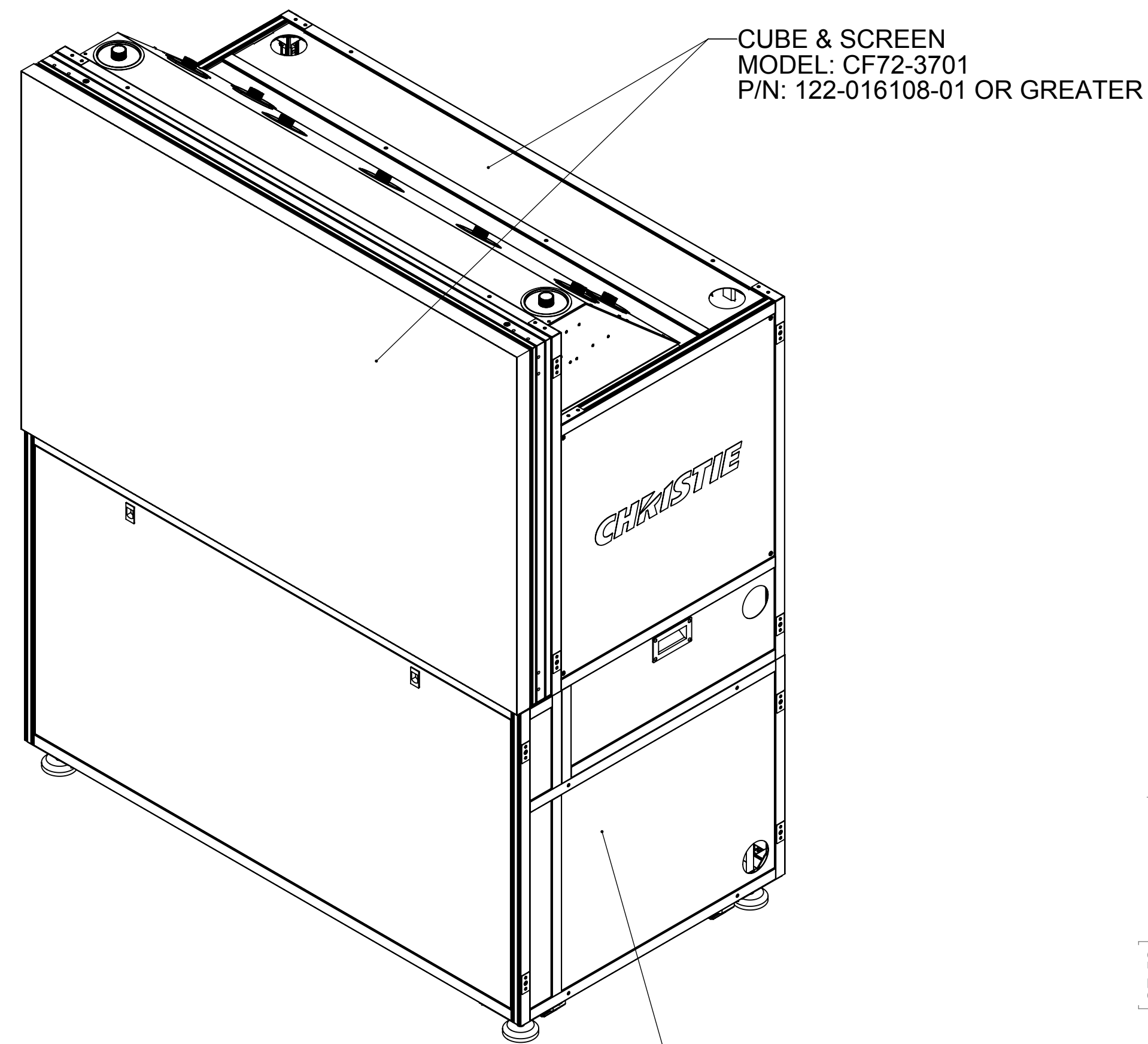

ISOMETRIC VIEW

CUBE WITH SCREEN ON PEDESTAL (SCREEN CLOSED)

CUBE & SCREEN
MODEL: CF72-3701
P/N: 122-016108-01 OR GREATER

PEDESTAL
MODEL: PF72-3601
P/N: 122-114107-01 OR GREATER

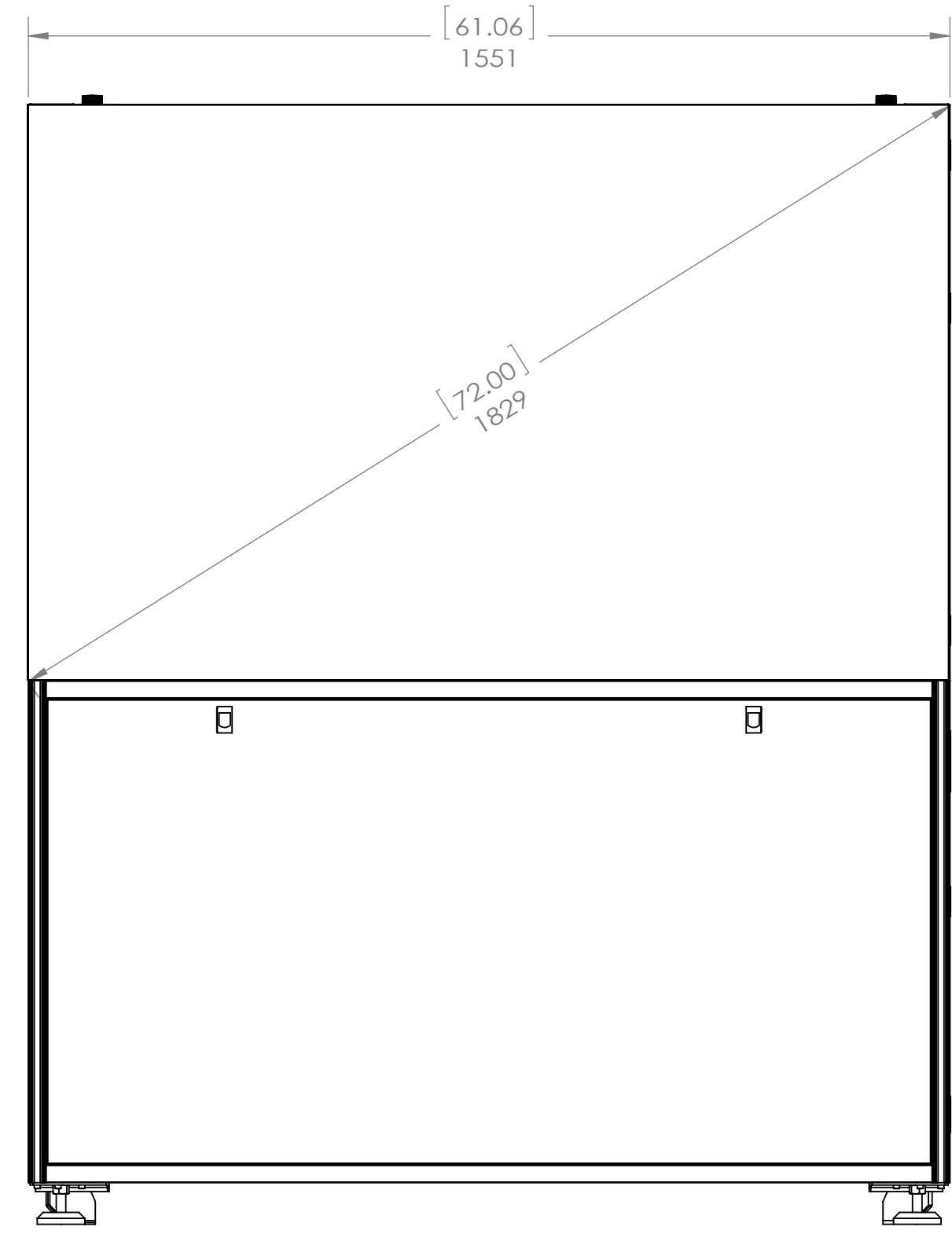

FRONT VIEW

CUBE WITH SCREEN ON PEDESTAL (SCREEN CLOSED)

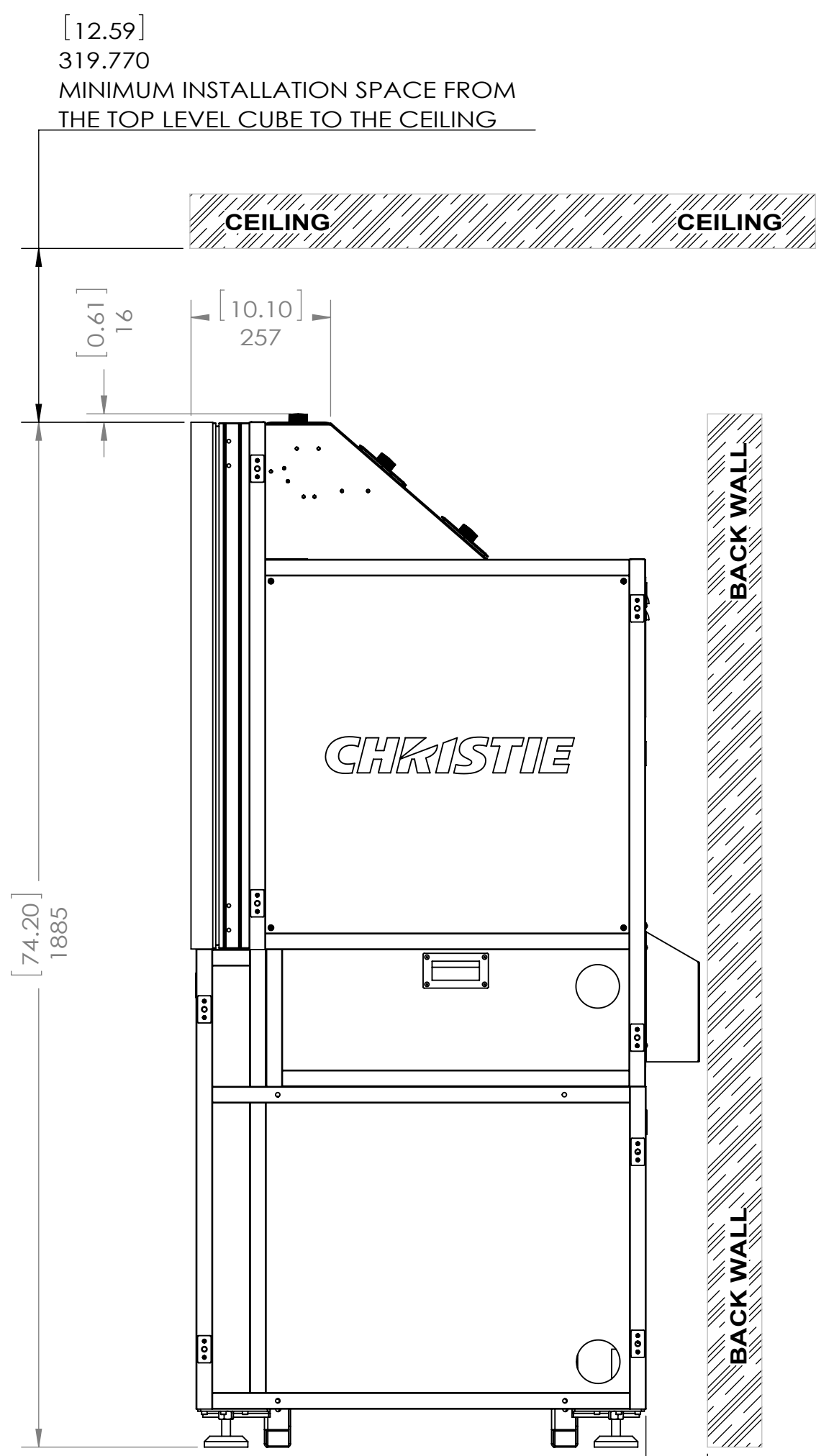

SIDE VIEW

CUBE WITH SCREEN ON PEDESTAL (SCREEN CLOSED)

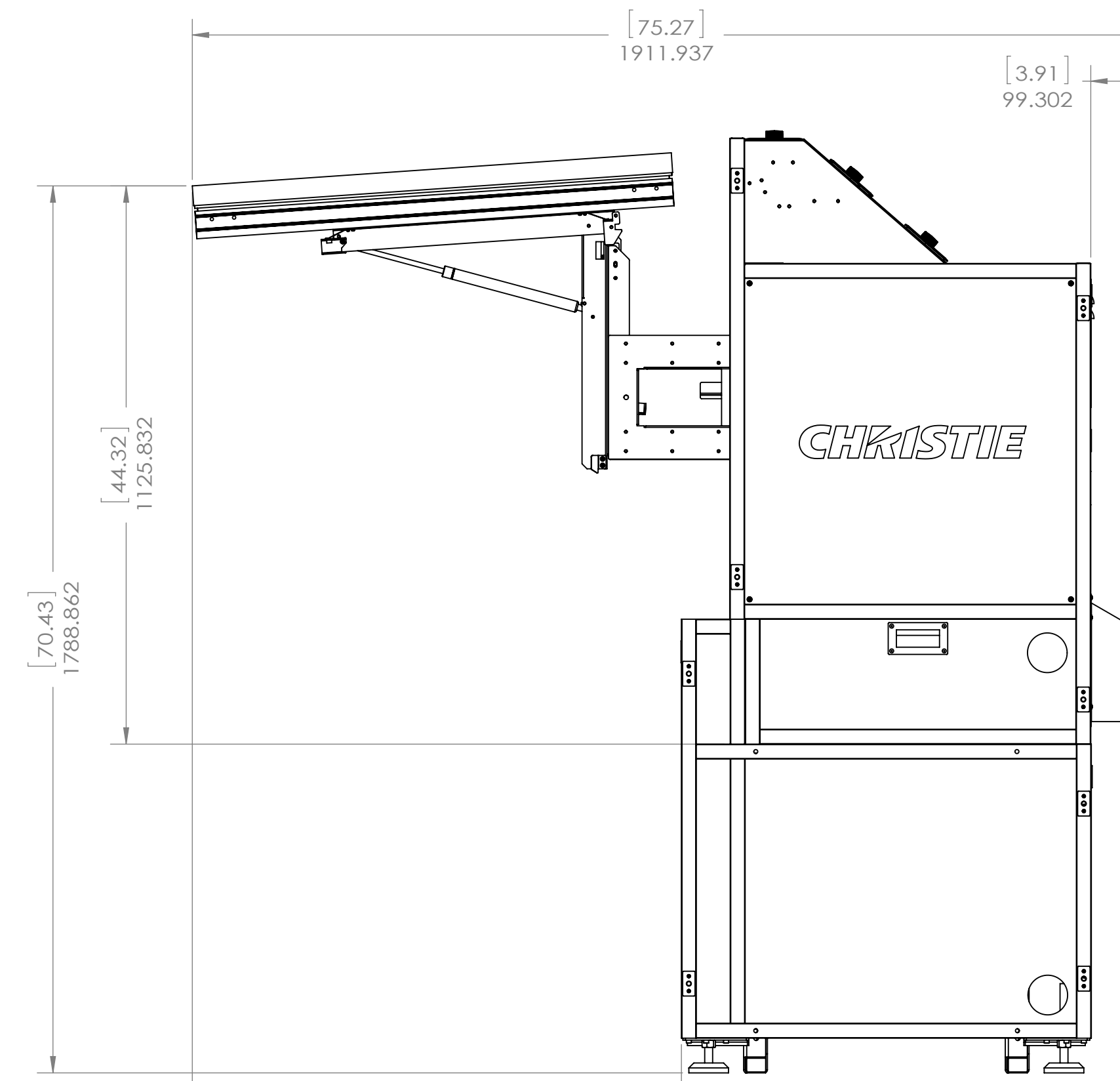

SIDE VIEW

CUBE WITH SCREEN ON PEDESTAL (SCREEN OPENED)

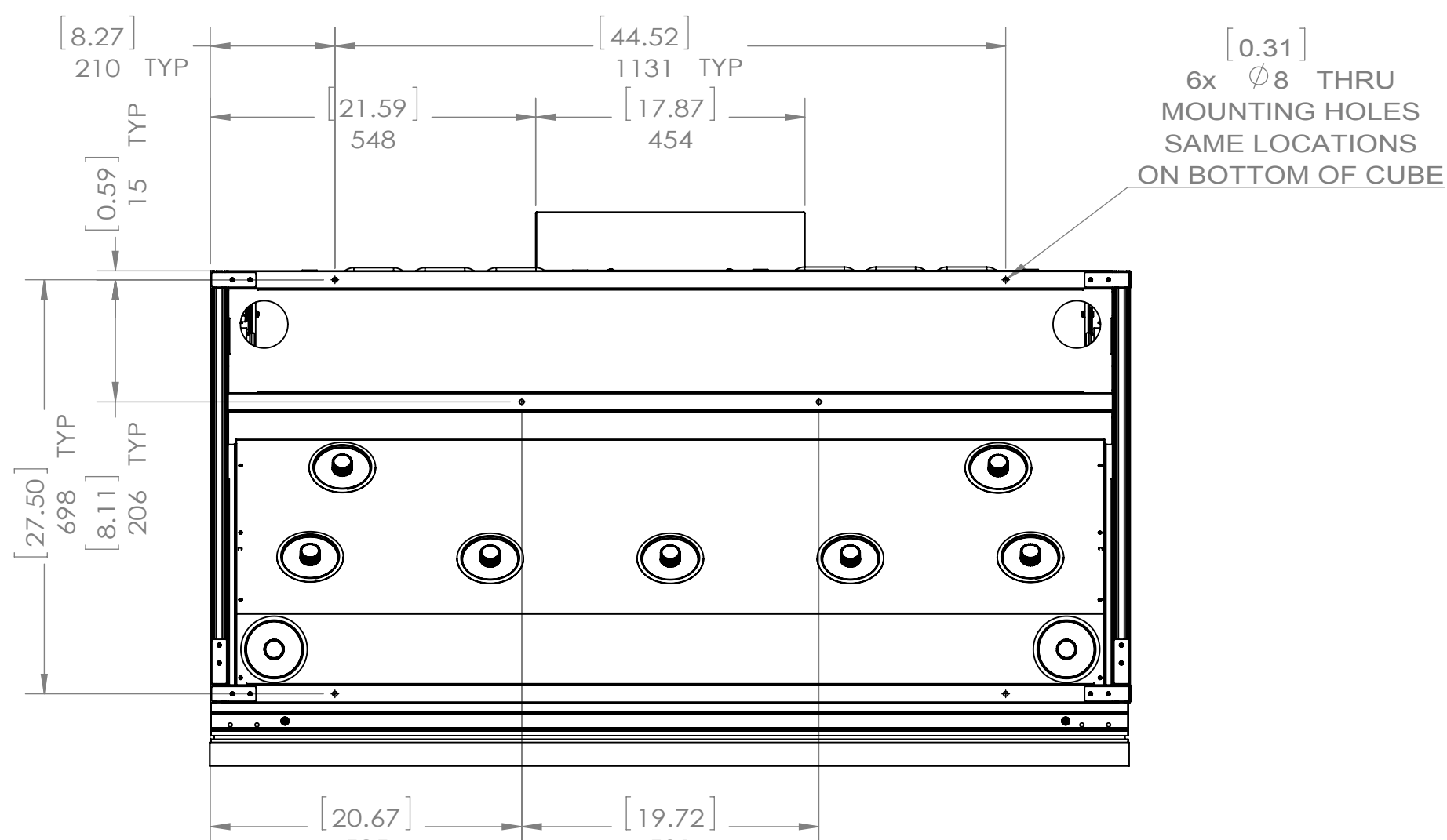

TOP VIEW

CUBE WITH SCREEN

6x Ø8 THRU MOUNTING HOLES SAME LOCATIONS ON BOTTOM OF CUBE

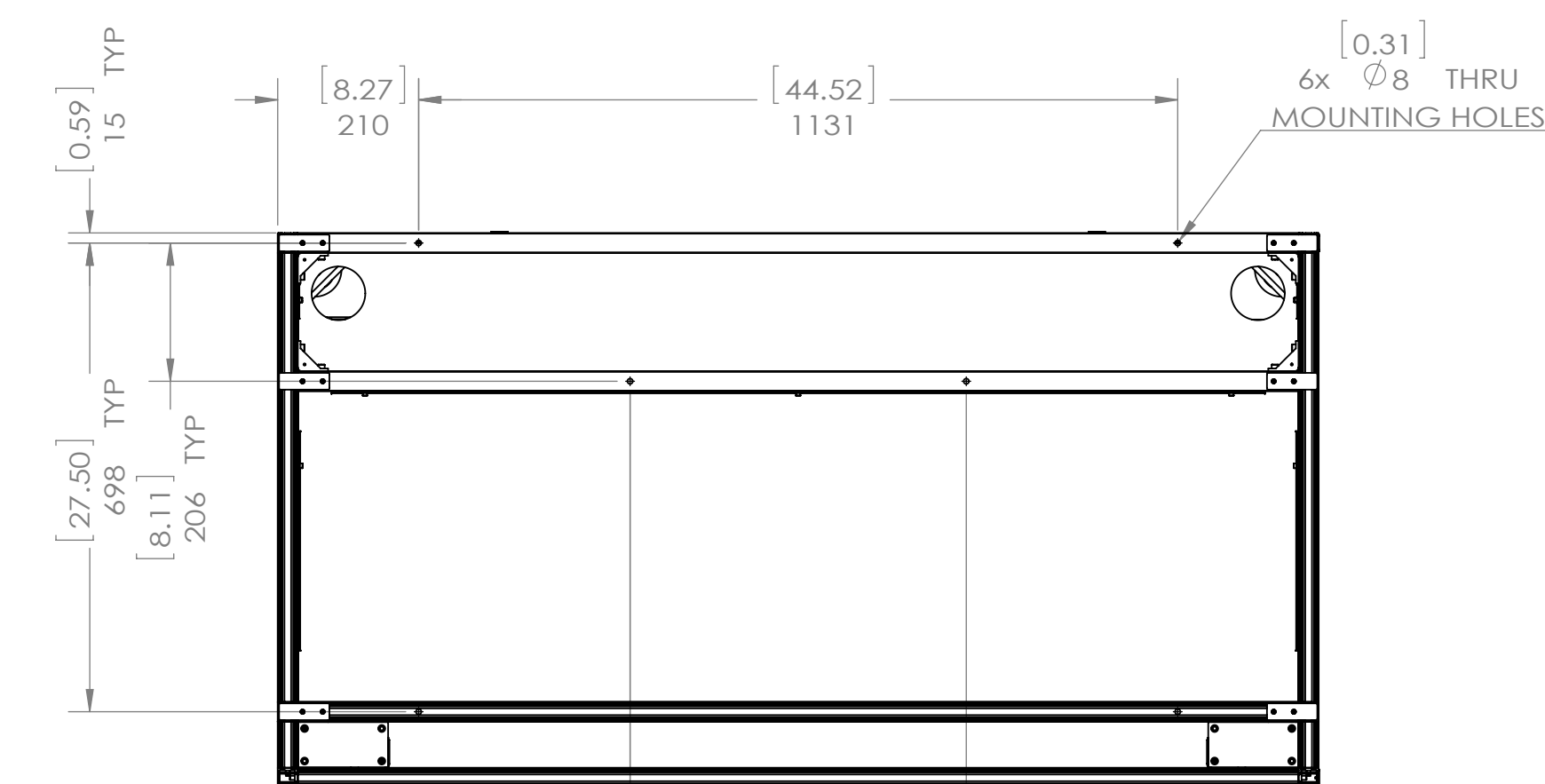

TOP VIEW

PEDESTAL

6x Ø8 THRU MOUNTING HOLES

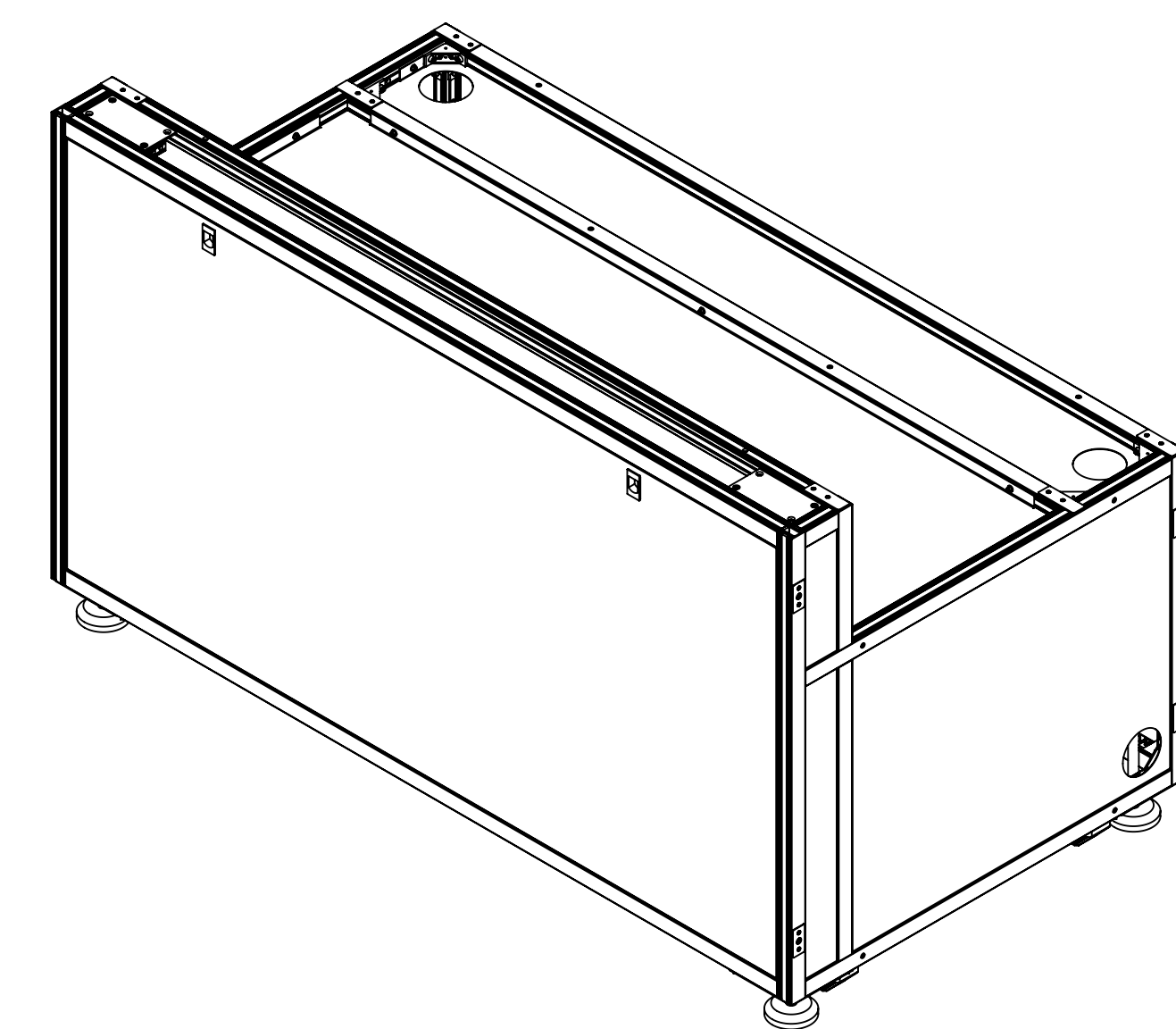

ISOMETRIC VIEW

PEDESTAL

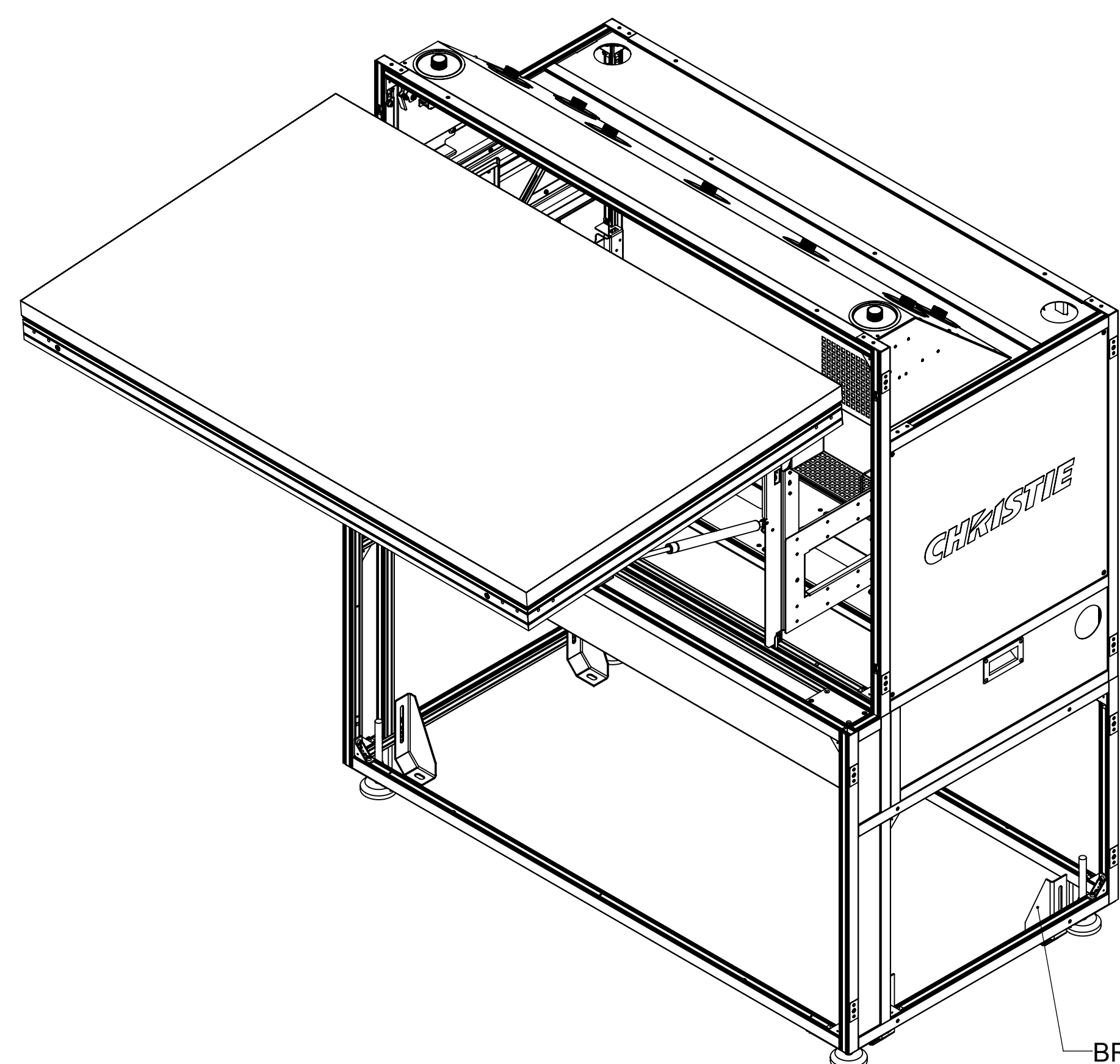

ISOMETRIC VIEW

CUBE WITH SCREEN ON PEDESTAL (SCREEN OPENED AND HIDDEN THE PANELS OF PEDESTAL)

BRKT SUPPORT BASE ADJ
P/N: 011-101340-01 OR GREATER

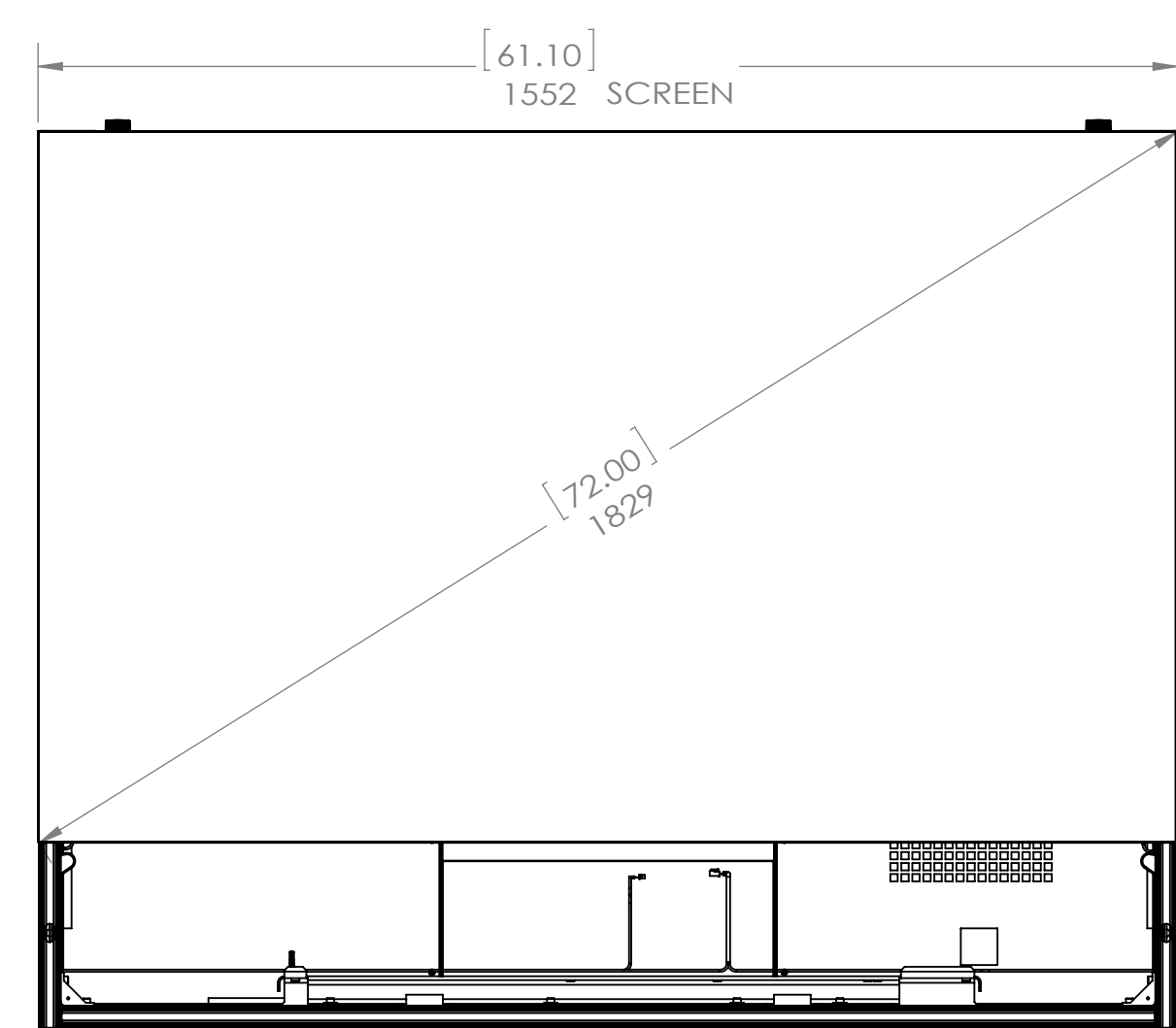

FRONT VIEW

CUBE WITH SCREEN

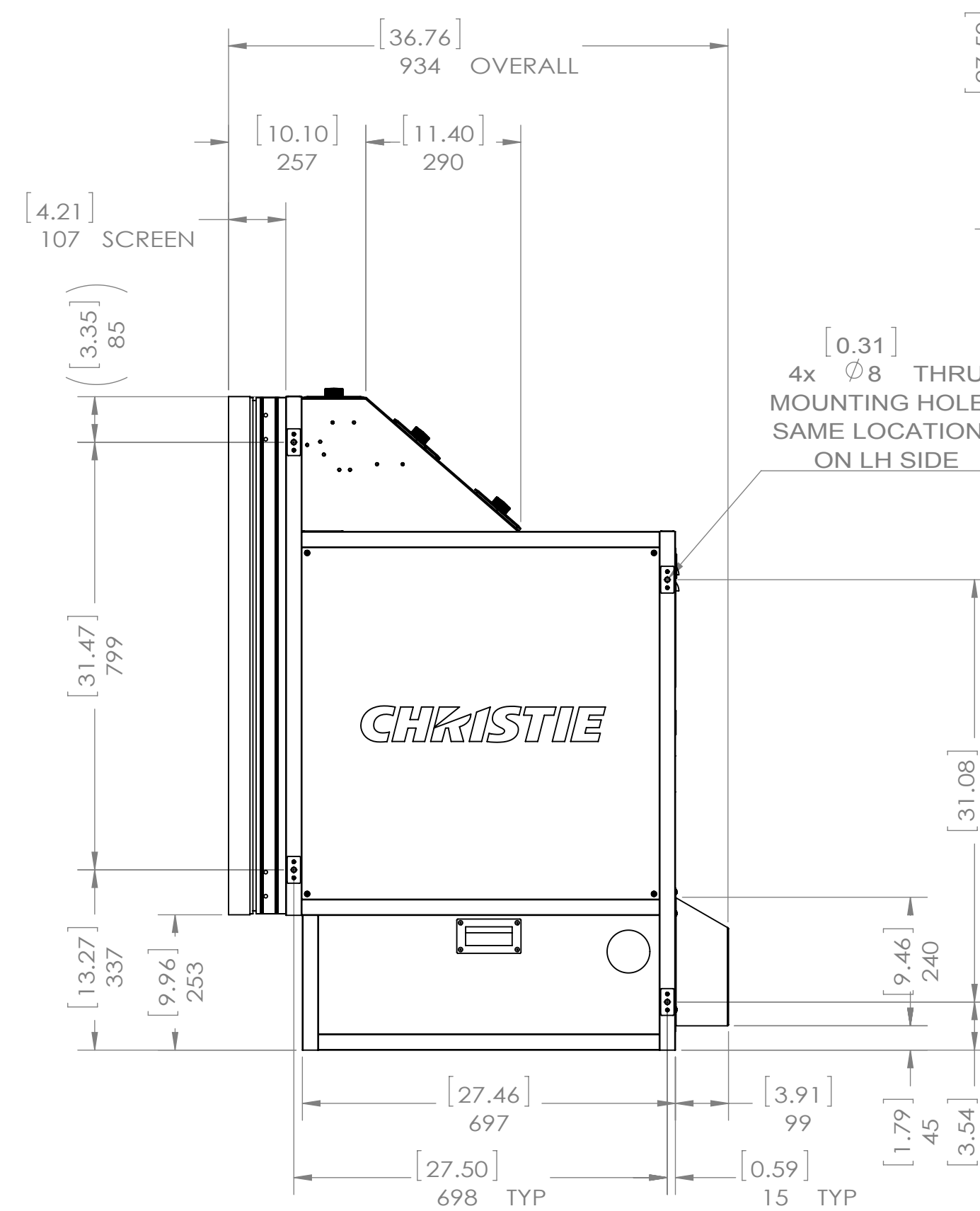

SIDE VIEW

CUBE WITH SCREEN

4x Ø8 THRU MOUNTING HOLES SAME LOCATIONS ON LH SIDE

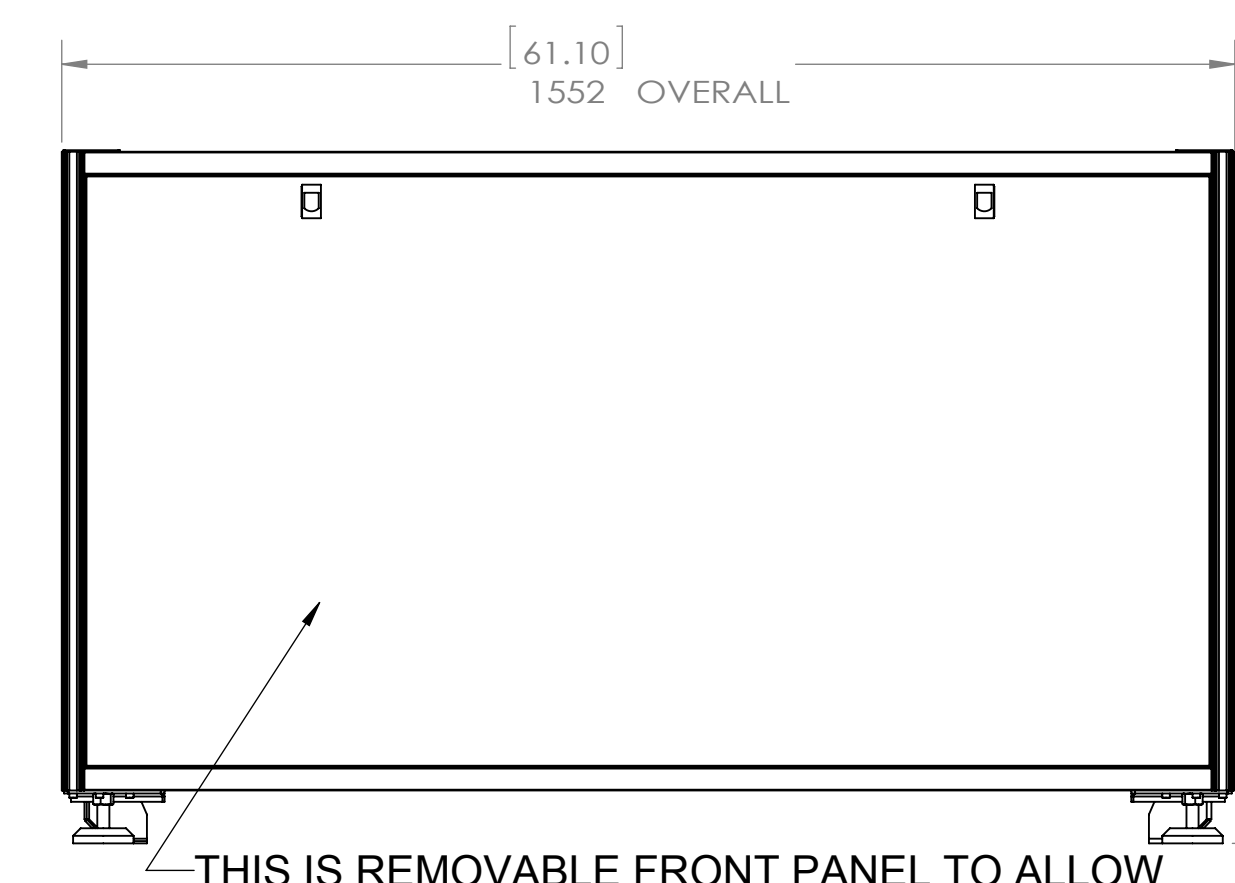

FRONT VIEW

PEDESTAL

36.02 SILL HEIGHT
915

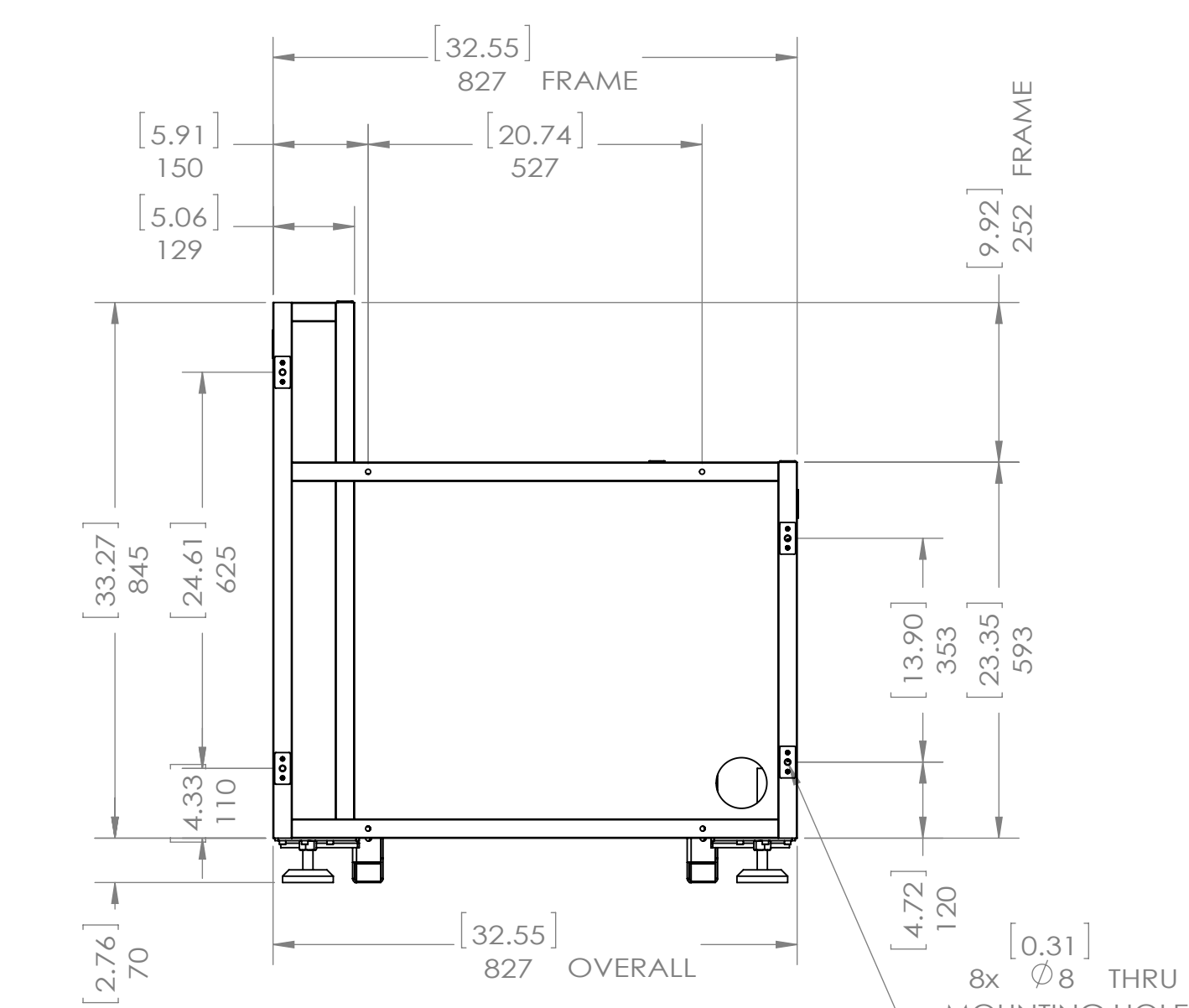

SIDE VIEW

PEDESTAL

6x Ø8 THRU MOUNTING HOLES SAME LOCATIONS ON LH SIDE

MODEL REV: 01	UNITS: MILLIMETRES	DRAWN BY: S. XUE	
MECH. REF #: M101649	UNLESS OTHERWISE SPECIFIED INTERPRET DIMENSIONS AND TOLERANCES PER ASME Y14.5M-1994	DRAWN DATE: 06/14/2014	
USED ON: ANT	MATERIAL: SEE INDIVIDUAL COMPONENTS	APPROVED BY: R. HONG	PROPRIETARY NOT TO BE DISCLOSED OR REPRODUCED IN ANY MANNER WITHOUT THE EXPRESS WRITTEN PERMISSION OF CHRISTIE
DEBURRING: NONE	FINISH: NONE	APPROVAL DATE: 05/04/2014	
COATING: NONE	COATING: NONE		THIRD ANGLE PROJECTION
I.D.:	MARK PART NO & VENDOR CODE (SUPPLIED BY CDS) IN LOCATION SHOWN		
SIMILAR TO: NONE			

CHRISTIE CHRISTIE DIGITAL SYSTEMS USA, INC. CHRISTIE DIGITAL SYSTEMS CANADA, INC.

CF 72, 72" 16:10 FA CUBE

REV: E PART NUMBER: 020-000747-01 1 OF 1